



QS318

# Quickship Commercial Products



**Centrifugal Roof & Wall Exhausters • Centrifugal Filtered Supply  
Propeller Roof Ventilators • Propeller Wall Fans • Recovery Ventilators  
Utility Sets • Ceiling/Cabinet Fans • Gravity Ventilators  
Inline Duct Fans • Upblast Restaurant Exhausters • Dampers, Shutters & Louvers**

**Quick Delivery • Wide Product Selection • Competitive Price**

*Advancing Ventilation*

# Table of Contents

Ship Programs / Warranty .....	3
<b>Centrifugal Roof &amp; Wall Exhausters</b>	
Model LPD Low Profile Direct Drive Roof/Sidewall Exhauster .....	4
Model SDBD Downblast Direct Drive Roof Exhauster .....	5
Model SDB Downblast Belt Drive Roof Exhauster .....	7
Model STXD Upblast Direct Drive Roof Exhauster .....	10
Model STXB-RHUL Upblast Belt Drive (Restaurant Roof Exhauster).....	12
Model CWD Direct Drive Sidewall Exhauster .....	15
<b>Centrifugal Filtered Supply</b>	
Model KSFV Belt Drive Filtered Roof Supply Fan .....	17
<b>Centrifugal Inline Fans</b>	
Model SQB Square Inline Belt Drive Duct Fan .....	20
Model SQD Square Inline Direct Drive Duct Fan .....	23
<b>Recovery Ventilators</b>	
Model TRC Total Recovery for All Climates - Commercial Applications .....	25
Model TRCe with EC Motors - Total Recovery for All Climates - Commercial Applications .....	34
<b>Propeller Roof Ventilators</b>	
Model ARE / ARS Dome Direct Drive Exhaust / Supply Roof Fan .....	43
<b>Propeller Wall Fans</b>	
Model GED Sidewall Direct Drive Propeller Exhaust Fan .....	45
Model LCE Sidewall Belt Drive Propeller Exhaust Fan .....	47
Model LCS Sidewall Belt Drive Propeller Supply Fan .....	49
<b>Utility Vent Sets</b>	
Model CM .....	51
<b>Gravity Ventilators</b>	
Model RCXII Gravity Relief/Intake Ventilator .....	65
<b>Ceiling/Cabinet Fans</b>	
Model AF/FF/FFC Ceiling & Inline/Cabinet Fans .....	67
<b>Accessories</b>	
Roof Curbs .....	73
Dampers For Roof Ventilators .....	74
Wall Shutters .....	75
Wall Housing Assembly .....	76
<b>Dampers &amp; Shutters</b>	
Model 411 - Auto Exhaust Damper .....	77
Model 611 - Auto Exhaust Damper .....	79
Model 502 - Automatic Wall Shutter .....	81
Model 556 - Automatic Wall Shutter .....	83
Model EAS-RF - Automatic Wall Shutter .....	85
Model EAS-HDGS - Automatic Wall Shutter .....	87
Model FGS - Automatic Wall Shutter .....	89
Model 304SS - Automatic Wall Shutter .....	91
Model EASB & EASW - Automatic Wall Shutter.....	93
Model AMD - Extruded Aluminum Motorized Damper .....	95
Model GMD - Galvanized Motorized Damper.....	97
Model ACD - Aluminum Motorized Hat Channel Damper.....	99
<b>Louvers</b>	
Model AFL - Aluminum Fixed Louver .....	101
Model GFL - Galvanneal Steel Fixed Louver .....	103
Model DFL - Extruded Aluminum Drainable Blade Fixed Louver .....	105
Model ACL - Extruded Aluminum Combination Louver/Damper.....	107
Model ADL - Aluminum Door Louver .....	109
Model SDL - Steel Door Louver.....	110
Models Cross Reference.....	111

# Quickship Program

Shipping Schedules for each catalog item are shown with one of the following symbols. Please refer to your price list or contact your sales representative for specific product availability. Quantities per order are limited to stock on hand.

● = Next Day Shipment from Stock

◆ = 10 Day Build-to-Order Program

▲ = 3 Day Shipment from Stock

△ = 3-4 Weeks for Commercial

## Freight Policy

Please refer to your price list for Freight Policy or contact your sales representative.

Shipping points may vary on occasion, but typically all products ship from Jacksonville, FL USA

Please check with your sales representative or our customer service team regarding shipment schedules & stock product availability, larger orders, additional accessories, special construction, technical support, application assistance, replacement parts, or any other service we can provide for you.

## Limited Warranty

**S&P USA** (Manufacturer) 6393 Powers Avenue, Jacksonville, Florida 32217, warrants equipment of its manufacture to be free from defects in design, materials and workmanship (exclusive of abrasion, corrosion or erosion) as noted in Warranty Chart from the date of shipment to the original purchaser or the date of notification of readiness to ship. Motor warranty is noted in Warranty Chart. In order to claim the benefit of this warranty, buyer must notify manufacturer in writing of the claimed defect within ten (10) days after discovering it and return this equipment or parts to the manufacturer with transportation prepaid. In the event of on-site repair, no service technician will be dispatched until manufacturer receives your written purchase order. If any of the following conditions exist, the warranty will be null and void: **(1)** Buyer has permitted other persons not approved or authorized by manufacturer to alter, adjust, replace or repair the equipment or any part thereof. **(2)** Buyer has not followed instructions or other directions given in the contract documents or our maintenance manual. **(3)** When breakage or other loss or damage is the result of any negligence, misuse or fault on the part of any operator or other person not under our supervision or control. **(4)** The defect is the result of designs or drawings made, furnished or specified by others. **(5)** In the case of goods not manufactured but supplied by the manufacturer as part of a contract, manufacturer shall only be liable to the same extent that our supplier is to manufacturer, not to exceed any liability manufacturer would have for warranty on our own equipment. **(6)** Buyer has not paid in full invoices submitted to the buyer which are due for payment. **(7)** Unusual wear and tear of the equipment.

Fan Model	Fan	Motor
LPD	5	3
SDBD	5	1
SDB	5	1
STXB-RHUL	2	1
STXD	5	1
STXD-RHUL	2	1
CWD	5	1
KSFV	5	1
SQB	2	1
SQD	2	1
TRC	SEE PAGE 25	
TRCe	SEE PAGE 32	
GED	5	1
LC	2	1
ARE/ARS	5	1
CM	5	1
CM-RHUL	2	1
RCXII	5	-
AF/FF/FFC	1	1

Statements relating to the product, its use or installation made prior to the execution of the agreement, are not warranties except to the extent that the contrary is expressly set forth herein. It is understood that such statements were not intended to, and did not, form a part of the agreement; they were merely made in the course of negotiations of the parties.

THIS WARRANTY IS IN LIEU OF ANY OTHER EXPRESSED OF IMPLIED WARRANTIES, INCLUDING ANY IMPLIED WARRANTY OF MERCHANTABILITY OR FITNESS FOR ANY PARTICULAR PURPOSE. OUR SOLE AND EXCLUSIVE OBLIGATION UNDER THIS WARRANTY IS TO REPAIR OR REPLACE DEFECTIVE EQUIPMENT OR PARTS OR, AT OUR OPTION, TO PAY THE REASONABLE COST OF REPAIR OR REPLACEMENT. BUYER AGREES THAT NO OTHER REMEDY (INCLUDING, BUT NOT LIMITED TO, INCIDENTAL OR CONSEQUENTIAL DAMAGES, DAMAGE FOR LOST PROFITS OR SALES, OR DAMAGES FOR INJURIES TO PERSON OR PROPERTY) SHALL BE AVAILABLE. NOTWITHSTANDING THE ABOVE, THE TOTAL AMOUNT THAT MAY IN ANY EVENT BE PAYABLE IN SETTLEMENT OR LIABILITY, HOWEVER INCURRED, SHALL NOT EXCEED THE CONTRACT PRICE.

# MODEL LPD

## LOW PROFILE DIRECT DRIVE CENTRIFUGAL ROOF/SIDEWALL EXHAUSTER



### FEATURES

- Ultra low profile
- AMCA Air & Sound Licensed
- UL 705 listed
- UPS shipping carton
- 5 year housing warranty
- Up to 140°F airstream temperature
- Roof or sidewall mount

### CONSTRUCTION

- Aluminum construction
- Stainless steel exterior fasteners
- Backward curved centrifugal wheel
- Aluminum birdscreen
- Conduit wiring chase
- Service disconnect switch
- Precision balanced to ISO Standard 1940

### MOTOR

- Unique external rotor design
- Permanently lubricated bearings
- 3-year motor warranty
- Internal thermal protection
- 100% speed controllable
- Totally enclosed and continuous duty

### AMCA SEAL



S&P USA Ventilation Systems, LLC., Div. of Soler & Palau Ventilation Group, certifies that the Models LPD shown herein are licensed to bear the AMCA Seal. The ratings shown are based on test and procedures performed in accordance with AMCA Publication 211 and AMCA Publication 311 and comply with the requirement of the AMCA Certified Ratings Program.



LISTED POWER  
ROOF VENTILATOR  
UL STANDARD 705

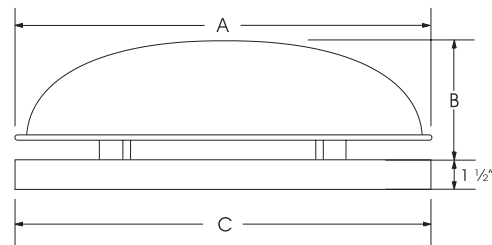

### DIMENSIONAL DATA

MODEL LPD	O.D. DAMPER	ROOF OPENING	CURB O.D.	A	B	C	AVERAGE SHIP WT. LBS.
6	11	11-3/4	14-3/4	16-1/2	7	16-1/2	12
8	11	11-3/4	14-3/4	16-1/2	7	16-1/2	15

Ship Schedules:
• Next Day Shipment From Stock

### ACCESSORIES

MODEL LPD	12" HIGH ROOF CURB	GRAVITY DAMPER	DAMPER MOTOR (LOOSE)	115 VOLT SPEED CONTROL
	STOCK NO.	STOCK NO.	STOCK NO.	STOCK NO.
6	611214 ●	411011 ●	411611 ●	2727.1 ●
8	611214 ●	411011 ●	411611 ●	2727.1 ●

### PERFORMANCE DATA

MODEL LPD	CFM @ STATIC PRESSURE											RPM (NOM.)	MAX MOTOR WATTS & AMPS	SONES @ 1/2"	VENTILATOR WITH TE MOTOR
	0	1/8	1/4	3/8	1/2	5/8	3/4	1	1 1/4	1 1/2	1 3/4				115/1/60 STOCK NO.
6	302	268	247	222	197	175	155	118	87	52	-	2800	90 WATTS 0.8 AMPS	7.2	LPD061AS ●
8	387	358	331	303	275	245	222	178	138	98	63	2775	115 WATTS 1.0 AMPS	11.9	LPD081AS ●

Performance certified is for installation type A-free inlet, free outlet. Performance ratings include the effects of birdscreen in the airstream. The sound ratings shown are loudness values in fan sones @ 5' (1.5m) in a hemispherical free field calculated per AMCA Standard 301. Installation Type A: free inlet hemispherical sone levels.

\*Base unit=AMCA Seal for Sound Rating does not apply to units with speed control + RPM range capable with solid state speed control. Speed (RPM) shown is normal. Performance is based on actual speed of test.

ALL DIMENSIONS IN INCHES, WEIGHTS IN POUNDS. OD IS OUTSIDE DIMENSION OF SQUARE CURB AND DAMPER. DUE TO CONTINUING RESEARCH, S&P RESERVES THE RIGHT TO CHANGE SPECIFICATIONS WITHOUT NOTICE.

Please refer to the General Catalog or contact the Factory for our Full Line of products available on standard shipping schedules.



# MODEL SDBD

## DOWNBLAST DIRECT DRIVE

## CENTRIFUGAL ROOF EXHAUSTER

### APPLICATION

Model SDBD direct drive units are used to exhaust air from all types of commercial and institutional buildings such as hospitals and health care facilities, schools, recreational buildings, machinery and equipment rooms, offices, retail stores and similar applications.

The nonoverloading wheel with its higher static pressure capability makes this unit suitable for either ducted or nonducted applications. It's roof mounting permits location near the area to be ventilated, allowing short duct runs and more efficient operation.

The spun aluminum exterior provides an attractive appearance and is compatible with belt driven Model SDB and companion gravity units to make up a complete ventilation system. Direct drive units use smaller diameter wheels, resulting in low sound levels and quiet operation. They have no belts or fan bearings to maintain or adjust and consequently require very little maintenance.

### CONSTRUCTION

#### Housing

- Curb cap has prepunched mounting holes for ease of installation.
- Fan plate isolates motor compartment from contaminated exhaust air.
- Spun aluminum hood and skirt for weather protection and attractive appearance.
- Heavy-gauge motor support for rigidity and strength
- Neoprene isolators for reduction of vibration and sound.
- Quick access to motor compartment for ease of maintenance.
- Conduit passage for easy electrical connection from below roof.
- Aluminum birdscreen and disconnect are included on standard models.

#### Centrifugal Wheel

- Non overloading for safe operation in ducted systems.
- Backward inclined wheels constructed of noncorrosive aluminum.
- Statically and dynamically balanced for smooth operation.

#### Speed Controllable Motors

- Standard motors are single speed, speed controllable and drip-proof.
- All motors are rated for continuous duty.
- Disconnect is standard with single speed drip-proof motors.
- Motors ship mounted as standard.

### DIMENSIONAL DATA

MODEL SDBD	A	B	C	D	ROOF OPENING	Average Ship Wt. Lbs.
6	18	14 1/8	22 5/16	1 1/2	13 1/2	109
7	18	16 13/16	22 5/16	4 1/8	13 1/2	109
8	18	20 1/2	22 5/16	4 1/8	13 1/2	109
10	18	20 1/2	22 5/16	5 1/8	13 1/2	109
12	20	27 5/16	27 5/8	3 7/8	15 1/2	122
14	20	27 5/16	27 5/8	3 7/8	15 1/2	126
15	24	28	32 7/8	4	19 1/2	140
16	24	28	32 7/8	4	19 1/2	140

### ACCESSORIES

MODEL SDBD	RECOMMENDED 12" HIGH MOUNTING CURB		RECOMMENDED GRAVITY DAMPER		DAMPER MOTOR (LOOSE)	115 VOLT SPEED CONTROL		230 VOLT SPEED CONTROL
	OD	STOCK NO.	OD	STOCK NO.	STOCK NO.	STOCK NO.	STOCK NO.	STOCK NO.
6	16 1/2	711216 ●	12	411012 ●	411611 ●	2727.1 ●	N/A	3232.1 ♦
7	16 1/2	711216 ●	12	411012 ●	411611 ●	2727.1 ●	N/A	3232.1 ♦
8	16 1/2	711216 ●	12	411012 ●	411611 ●	2727.1 ●	N/A	3232.1 ♦
10	16 1/2	711216 ●	12	411012 ●	411611 ●	2727.1 ●	2828.1 ●	3232.1 ♦
12	18 1/2	711218 ●	14	411014 ●	411611 ●	2727.1 ●	2828.1 ●	3232.1 ♦
14	18 1/2	711218 ●	14	411014 ●	411611 ●	2727.1 ●	N/A	3232.1 ♦
15	22 1/2	711222 ●	18	411018 ●	411611 ●	N/A	2828.1 ●	3232.1 ♦
16	22 1/2	711222 ●	18	411018 ●	411611 ●	N/A	2828.1 ●	3232.1 ♦

ALL DIMENSIONS IN INCHES, WEIGHTS IN POUNDS. OD IS OUTSIDE DIMENSION OF SQUARE CURB AND DAMPER. DUE TO CONTINUING RESEARCH, S&P RESERVES THE RIGHT TO CHANGE SPECIFICATIONS WITHOUT NOTICE.

*Please refer to the General Catalog or contact the Factory for our Full Line of products available on standard shipping schedules.*



### AMCA SEAL



S&P USA Ventilation Systems, LLC., Div. of Soler & Palau Ventilation Group, certifies that the Models SDBD shown herein are licensed to bear the AMCA Seal. The ratings shown are based on test and procedures performed in accordance with AMCA Publication 211 and AMCA Publication 311 and comply with the requirement of the AMCA Certified Ratings Program.



LISTED POWER  
ROOF VENTILATOR  
UL STANDARD 705

### SPEED CONTROL

#### Solid State Speed Control:

Control is matched to the motor and blower wheel to allow continuous reduction in performance allowing adjustments of airflow for system balancing. CFM is reduced in direct proportion to motor speed reduction. Speed control is only available for single phase. Exhauster performance can be controlled from the ventilated area.

**2727.1 MAX 1/3 HP-5 AMP 120V**

**2828.1 MAX 1/2 HP-10 AMP 120V**

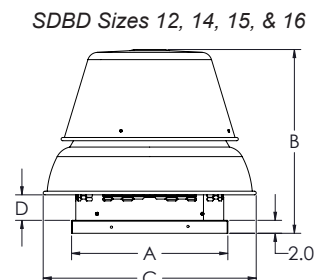
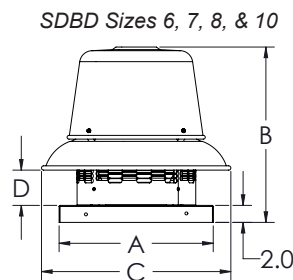

#### Ship Schedules:

- Next Day Shipment From Stock
- ▲ 3 Day Shipment From Stock
- ♦ 10 Day Shipment

MODEL SDBD		Downblast Direct Drive Centrifugal Roof Exhauster													Ventilator with Open Drip-proof Motor		
															115/1/60	208-230/1/60	
Model SDBD	Motor Hp	Max. BHp	RPM	Sones @ 1/8 SP	CFM at Static Pressure										Stock No.	Stock No.	
					0	1/8	1/4	3/8	1/2	5/8	3/4	7/8	1	1-1/4			
6C	1/10	.07	1650	7.0	182	153	131	107	71							SDBD06CJH1AS ●	SDBD06CJH1CS ◆
6	1/10	.05	1650	6.5	351	300	245	190	114							SDBD06JH1AS ●	SDBD06JH1CS ◆
7	1/10	.09	1650	7.2	476	429	380	329	266	199	94					SDBD07JH1AS ●	SDBD07JH1CS ◆
8	1/25	.03	1150	6.5	592	514	421	206								SDBD08HM1AS ●	-
	1/10	.07	1650	10.3	862	804	733	662	576	485	343					SDBD08JH1AS ●	SDBD08JH1CS ◆
	1/4	.12	1750	11.3	892	842	789	738	667	595	505	297				SDBD08MH1AS ●	SDBD08MH1CS ◆
10	1/4	.09	1150	7.6	949	847	738	607	419							SDBD10MM1AS ●	SDBD10MM1CS ◆
	1/3	.24	1700	12.6	1348	1282	1214	1137	1060	977	886	783	653			SDBD10PH1AS ●	SDBD10PH1CS ◆
12	1/4	.16	1150	8.5	1281	1176	1050	909	719	312						SDBD12MM1AS ●	SDBD12MM1CS ◆
	1/2	.40	1700	15.4	1885	1812	1734	1653	1572	1479	1377	1267	1144	753		SDBD12QH1AS ●	SDBD12QH1CS ◆
14	1/4	.26	1100	12.3	2196	2047	1864	1673	1428	1115						SDBD14MM1AS ●	SDBD14MM1CS ◆
15	1/2	.39	1150	14.8	2685	2565	2440	2289	2109	1913	1690	1260				SDBD15QM1AS ●	SDBD15QM1CS ◆
16	1/2	.49	1150	17.3	3298	3150	3002	2835	2663	2468	2234	1975				SDBD16QM1AS ●	SDBD16QM1CS ◆

Speed (RPM) shown is nominal. Performance is based on actual speed of test.  
Performance certified is for installation type A-free inlet, free outlet.  
Performance ratings include the effects of birdscreen in the airstream.

The sound ratings shown are the loudness values in the fan sones @ 5' (1.5m) in an hemispherical free field calculated per AMCA Standard 301.  
Installation Type A: free inlet hemispherical sone levels.

Ship Schedules:
● Next Day Shipment From Stock
▲ 3 Day Shipment From Stock
◆ 10 Day Shipment

# MODEL SDB

## DOWNBLAST BELT DRIVE

### CENTRIFUGAL ROOF EXHAUSTER

#### APPLICATION

Model SDB belt drive units are used for the exhaust of relatively clean air from a wide range of commercial, industrial and institutional environments such as manufacturing and assembly plants, office buildings, schools, hospitals, restaurants, athletic facilities and many others.

The nonoverloading wheel with its higher static pressure capabilities makes this unit suitable for either ducted or nonducted applications. It's roof mounting permits location near the area to be ventilated, allowing short duct runs and more efficient operation.

The aluminum exterior provides an attractive appearance. Belt drive results in lower operating RPM and sound levels, making the Model DB well suited to applications where quiet operation is important. Belt drive also permits easy performance adjustments when needed to balance the total ventilation system.

#### CONSTRUCTION

##### Housing

- Heavy-gauge aluminum for extra strength with prepunched mounting holes.
- Neoprene isolators for reduction of vibration and sound.
- Cover easily removed for quick access to motor compartment.
- Water tight conduit tube for easy electrical connection.
- Aluminum birdscreen and disconnect are standard.
- Lifting lugs for easy and safe placement on roof.
- Stainless steel exterior fasteners.

##### Centrifugal Wheel

- All aluminum backward inclined wheel.
- Nonoverloading for safe operation in ducted systems.
- Dynamically balanced for smooth operation.

##### Drives

- Sized for minimum 150% of drive horsepower.
- Machined cast iron adjustable motor pulleys.
- Adjustable base for belt tensioning.
- Nonstatic oil resistant v-belts.

#### DIMENSIONAL DATA

MODEL SDB	A	B	C	D	ROOF OPENING	Average Ship Wt. Lbs.
6	18	30 1/8	25	3 3/8	13 1/2	109
7	18	30 1/8	25	3 3/8	13 1/2	109
8	18	30 1/8	25	3 3/8	13 1/2	109
10	18	30 1/8	25	3 3/8	13 1/2	109
12	20	31 11/16	27 5/8	3 7/8	15 1/2	122
14	20	31 11/16	27 5/8	3 7/8	15 1/2	126
15	24	32 1/2	32 7/8	4	19 1/2	140
16	24	32 1/2	32 7/8	4	19 1/2	140
18	30	36 3/8	39 3/16	4 5/8	25 1/2	156
20	30	38 5/16	45	6 1/8	25 1/2	166
22	30	38 5/16	45	6 1/8	25 1/2	170
24	36	46 5/8	49 3/8	6	31 1/2	270
27	36	49 1/16	49 3/8	8 1/2	31 1/2	280
30	42	50 1/4	56	7 3/8	37 1/2	300



#### Motors

- Single speed open drip-proof are standard.
- All motors are rated for continuous duty.
- 182T and larger motors shipped unmounted for field installation.
- Disconnect switch standard with single speed drip-proof motors.

#### Bearings

- Heavy-duty ball bearing type.
- Prelubricated and permanently sealed.

#### AMCA SEAL



S&P USA Ventilation Systems, LLC., Div. of Soler & Palau Ventilation Group, certifies that the Models SDB shown herein are licensed to bear the AMCA Seal. The ratings shown are based on test and procedures performed in accordance with AMCA Publication 211 and AMCA Publication 311 and comply with the requirement of the AMCA Certified Ratings Program.

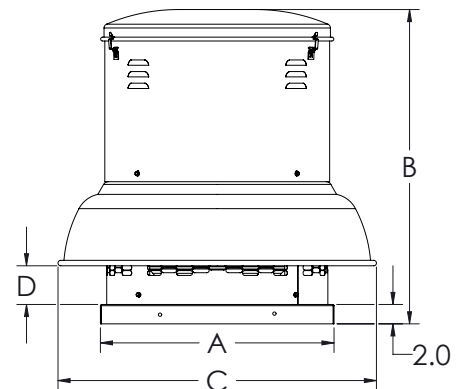

Ship Schedules:	
●	Next Day Shipment From Stock
▲	3 Day Shipment From Stock
◆	10 Day Shipment

ALL DIMENSIONS IN INCHES, WEIGHTS IN POUNDS. OD IS OUTSIDE DIMENSION OF SQUARE CURB AND DAMPER. DUE TO CONTINUING RESEARCH, S&P RESERVES THE RIGHT TO CHANGE SPECIFICATIONS WITHOUT NOTICE.

*Please refer to the General Catalog or contact the Factory for our Full Line of products available on standard shipping schedules.*

## ACCESSORIES

MODEL SDB	RECOMMENDED 12" HIGH MOUNTING CURB		RECOMMENDED GRAVITY DAMPER		DAMPER MOTOR (LOOSE)		AUTOMATIC BELT TENSIONER (INSTALLED)	
	OD	STOCK NO.	OD	STOCK NO.	STOCK NO.	STOCK NO.	STOCK NO.	STOCK NO.
6	16 1/2	711216 ●	12	411012 ●	411611 ●	411611 ●	100069 ●	100069 ●
7	16 1/2	711216 ●	12	411012 ●	411611 ●	411611 ●	100069 ●	100069 ●
8	16 1/2	711216 ●	12	411012 ●	411611 ●	411611 ●	100069 ●	100069 ●
10	16 1/2	711216 ●	12	411012 ●	411611 ●	411611 ●	100069 ●	100069 ●
12	18 1/2	711218 ●	14	411014 ●	411611 ●	411611 ●	100070 ●	100070 ●
14	18 1/2	711218 ●	14	411014 ●	411611 ●	411611 ●	100070 ●	100070 ●
15	22 1/2	711222 ●	18	411018 ●	411611 ●	411611 ●	100070 ●	100070 ●
16	22 1/2	711222 ●	18	411018 ●	411611 ●	411611 ●	100070 ●	100070 ●
18	28 1/2	711228 ●	24	411024 ●	411611 ●	411611 ●	100072 ●	100072 ●
20	28 1/2	711228 ●	24	411024 ●	411611 ●	411611 ●	100072 ●	100072 ●
22	28 1/2	711228 ●	24	411024 ●	411611 ●	411611 ●	100072 ●	100072 ●
24	34 1/2	711234 ●	30	411030 ●	411611 ●	411611 ●	100072 ●	100072 ●

Ship Schedules:
● Next Day Shipment From Stock
▲ 3 Day Shipment From Stock
◆ 10 Day Shipment

Curb Cap adaptors are available to match old style DB and competitors curb caps. Refer to Optisizer2 for sizes available on Quickship.

# MODEL SDB

## Downblast Belt Drive Centrifugal Roof Exhauster

Ventilator with Open Drip-proof Motor and Drive Assembly

Model SDB	Motor Hp	Max. BHP	RPM	Sones @ 1/4 SP	CFM at Static Pressure											115/1/60*		208-230-460/3/60	
					0	1/8	1/4	3/8	1/2	5/8	3/4	7/8	1	1-1/4	1-1/2	Stock No.	Stock No.		
6	1/4	0.11	1,600	8.2	300	275	246	215	176	109	-	-	-	-	-	SDB06ML1S ●	SDB06ML3S ▲		
	1/4	0.15	1,800	9.7	337	315	291	265	235	201	144	80	-	-	-	SDB06MM1S ●	SDB06MM3S ▲		
	1/4	0.21	2,000	11.4	375	355	335	310	288	260	229	184	-	-	-	SDB06MH1S ●	SDB06MH3S ▲		
7	1/4	0.11	1,600	8.5	438	388	336	277	204	119	-	-	-	-	-	SDB07ML1S ●	SDB07ML3S ▲		
	1/4	0.16	1,800	10.2	493	449	402	356	300	234	158	-	-	-	-	SDB07MM1S ●	SDB07MM3S ▲		
	1/4	0.21	2,000	11.9	547	507	466	425	381	330	272	202	-	-	-	SDB07MH1S ●	SDB07MH3S ▲		
8	1/4	0.13	1,550	9.1	835	775	716	648	565	402	-	-	-	-	-	SDB08ML1S ●	SDB08ML3S ▲		
	1/4	0.19	1,750	11.1	943	888	838	782	720	646	535	-	-	-	-	SDB08MM1S ●	SDB08MM3S ▲		
	1/4	0.26	1,950	13.2	1051	1001	956	909	857	800	733	652	-	-	-	SDB08MH1S ●	SDB08MH3S ▲		
	1/3	0.33	2,100	15.0	1132	1085	1043	1000	954	905	850	787	712	-	-	SDB08PH1S ●	SDB08PH3S ▲		
10	1/4	0.19	1,450	10.8	1213	1148	1077	997	906	796	640	-	-	-	-	SDB10ML1S ●	SDB10ML3S ▲		
	1/4	0.26	1,600	12.8	1339	1280	1217	1148	1073	988	888	768	-	-	-	SDB10MH1S ●	SDB10MH3S ▲		
	1/3	0.34	1,750	14.8	1464	1411	1355	1294	1228	1158	1079	989	888	-	-	SDB10PH1S ●	SDB10PH3S ▲		
12	1/4	0.25	1,400	11.1	1540	1459	1378	1277	1170	1053	913	-	-	-	-	SDB12MH1S ●	SDB12MH3S ▲		
	1/3	0.34	1,550	13.2	1705	1632	1560	1477	1383	1286	1181	1057	885	-	-	SDB12PH1S ●	SDB12PH3S ▲		
	1/2	0.49	1,750	16.0	1925	1860	1797	1731	1653	1569	1483	1396	1296	1042	-	SDB12QH1S ●	SDB12QH3S ●		
14	1/4	0.27	1,100	10.0	2216	2081	1946	1787	1604	1324	-	-	-	-	-	SDB14MH1S ●	SDB14MH3S ▲		
	1/3	0.5	1,200	11.8	2417	2293	2172	2038	1878	1702	1427	-	-	-	-	SDB14PH1S ●	SDB14PH3S ▲		
	1/2	0.55	1,400	15.9	2820	2714	2610	2504	2388	2255	2114	1950	1714	-	-	SDB14QH1S ●	SDB14QH3S ●		
	3/4	0.75	1,550	19.0	3122	3026	2931	2838	2739	2633	2512	2385	2252	1846	-	SDB14RH1S ●	SDB14RH3S ●		
	1	1.08	1,750	23.0	3525	3440	3355	3273	3189	3102	3009	2908	2797	2568	2247	SDB14SH1S ●	SDB14SH3S ●		
15	1/4	0.26	1,000	10.0	2327	2197	2037	1870	1687	1393	-	-	-	-	-	SDB15MH1S ●	SDB15MH3S ▲		
	1/3	0.35	1,100	11.7	2560	2445	2301	2156	1996	1823	1553	-	-	-	-	SDB15PH1S ●	SDB15PH3S ▲		
	1/2	0.51	1,250	14.4	2909	2811	2691	2562	2434	2292	2149	1965	-	-	-	SDB15QH1S ●	SDB15QH3S ●		
	3/4	0.8	1,450	18.8	3375	3292	3196	3087	2976	2866	2749	2624	2502	2150	-	SDB15RH1S ●	SDB15RH3S ●		
	1	1.07	1,600	22.0	3724	3650	3567	3472	3370	3271	3172	3067	2956	2729	2412	SDB15SH1S ●	SDB15SH3S ●		
16	1/4	0.26	900	9.1	2566	2403	2219	2015	1739	-	-	-	-	-	-	SDB16MH1S ●	SDB16MH3S ▲		
	1/3	0.36	1,000	11.1	2851	2707	2544	2373	2174	1915	-	-	-	-	-	SDB16PH1S ●	SDB16PH3S ●		
	1/2	0.54	1,150	14.0	3279	3156	3019	2874	2724	2557	2345	2095	-	-	-	SDB16QH1S ●	SDB16QH3S ●		
	3/4	0.78	1,300	17.6	3707	3599	3482	3356	3228	3094	2952	2782	2585	-	-	SDB16RH1S ●	SDB16RH3S ●		
	1	1.08	1,450	22.0	4135	4038	3936	3827	3713	3597	3478	3354	3216	2875	2467	SDB16SH1S ●	SDB16SH3S ●		
	18	1/3	0.3	750	8.4	2993	2770	2542	2309	1934	1389	-	-	-	-	-	SDB18PH1S ●	SDB18PH3S ◆	
1/2	0.53	900	12.0	3592	3401	3224	3027	2839	2594	2232	1816	-	-	-	-	SDB18QH1S ●	SDB18QH3S ●		
3/4	0.72	1,000	14.9	3991	3818	3657	3490	3313	3144	2927	2617	2279	-	-	-	SDB18RH1S ●	SDB18RH3S ●		
1	1.1	1,150	18.9	4590	4439	4295	4157	4008	3852	3709	3550	3352	2797	-	-	SDB18SH1S ●	SDB18SH3S ●		
1-1/2	1.59	1,300	22.9	5188	5054	4924	4801	4678	4546	4408	4277	4149	3832	-	-	SDB18TH1S ●	SDB18TH3S ●		
2	2.16	1,450	27.0	5787	5666	5548	5435	5326	5215	5098	4975	4850	4622	-	-	SDB18VH1S ▲	SDB18VH3S ●		
20	1/3	0.29	650	7.1	3254	2971	2685	2376	1802	-	-	-	-	-	-	SDB20PH1S ●	SDB20PH3S ◆		
	1/2	0.55	800	10.9	4006	3780	3544	3312	3059	2800	2305	-	-	-	-	SDB20QH1S ●	SDB20QH3S ●		
	3/4	0.79	900	13.4	4506	4307	4097	3893	3680	3454	3227	2921	-	-	-	SDB20RH1S ●	SDB20RH3S ●		
	1	1.08	1,000	15.7	5007	4828	4641	4452	4272	4076	3870	3676	3457	-	-	SDB20SH1S ●	SDB20SH3S ●		
	1-1/2	1.64	1,150	19.6	5758	5603	5444	5279	5115	4958	4796	4618	4440	4083	-	-	SDB20TH1S ●	SDB20TH3S ●	
	2	2.07	1,250	22.4	6259	6117	5971	5821	5668	5520	5376	5227	5065	4744	-	-	SDB20VH1S ◆	SDB20VH3S ●	
	22	1/3	0.34	550	8.8	4454	3975	3399	-	-	-	-	-	-	-	-	SDB22PH1S ●	SDB22PH3S ●	
1/2	0.57	650	11.6	5264	4863	4409	3901	2989	-	-	-	-	-	-	-	SDB22QH1S ●	SDB22QH3S ●		
3/4	0.71	700	13.3	5669	5296	4892	4443	3909	-	-	-	-	-	-	-	SDB22RH1S ●	SDB22RH3S ●		
1	1.06	800	16.5	6478	6151	5822	5438	5043	4570	3777	-	-	-	-	-	SDB22SH1S ●	SDB22SH3S ●		
1-1/2	1.51	900	20.1	7288	6997	6709	6396	6048	5697	5291	4803	-	-	-	-	SDB22TH1S ●	SDB22TH3S ●		
2	2.07	1,000	24.1	8098	7836	7576	7313	7015	6701	6387	6039	5648	-	-	-	SDB22VH1S ◆	SDB22VH3S ●		
24	1/3	0.28	450	5.8	4643	4010	3264	-	-	-	-	-	-	-	-	SDB24PH1S ◆	SDB24PH3S ◆		
	1/2	0.51	550	9.3	5675	5151	4621	3979	-	-	-	-	-	-	-	SDB24QH1S ◆	SDB24QH3S ◆		
	3/4	0.84	650	13.9	6707	6252	5831	5356	4822	-	-	-	-	-	-	SDB24RH1S ◆	SDB24RH3S ◆		
	1	1.05	700	15.9	7223	6796	6407	5990	5519	4977	-	-	-	-	-	SDB24SH1S ◆	SDB24SH3S ◆		
	1-1/2	1.57	800	19.4	8255	7875	7531	7187	6814	6400	5964	-	-	-	-	SDB24TH1S ◆	SDB24TH3S ◆		
	2	2.23	900	23.2	9287	8946	8632	8332	8021	7688	7323	6950	6527	-	-	SDB24VH1S ◆	SDB24VH3S ◆		

Power ratings (BHP) do not include transmission losses.

Performance certified for installation type A-free inlet, free outlet. Performance ratings include the effects of birdscreen in the airstream.

The sound ratings shown are loudness values in fan sones @ 5' (1.5m) in a hemispherical free field calculated per AMCA Standard 301.

Installation Type A: free inlet hemispherical sone levels.

\*Tri-voltage (115-208-230) is standard on 3/4 through 1 1/2 Hp Single phase motors. Tri-voltage is available for the 1/2 Hp motors. Inquire for price and delivery.

**Please refer to the General Catalog or contact the Factory for our Full Line of products available on standard shipping schedules.**

# MODEL STXD & STXD-RHUL

## UPBLAST DIRECT DRIVE CENTRIFUGAL ROOF/SIDEWALL EXHAUSTER FOR GENERAL AND RESTAURANT APPLICATIONS



### APPLICATION

Isolation of the motor from the air stream and the high velocity vertical (roof) or horizontal (wall) air discharge make the Model STXD ideally suited for the removal of dirty, contaminated and/or high temperature air from processes and buildings. Typical applications include restaurant hoods and similar kitchen exhaust ventilation, fume and smoke removal, laboratory fume hood exhaust and chemical process exhaust.

The nonoverloading wheel with its higher static pressure capability makes this unit suitable for either ducted or nonducted applications. Its roof or wall mounting permits location near the area to be ventilated, allowing short duct runs and more efficient operation. They have no belts or fan bearings to maintain or adjust and consequently require very little maintenance.

### CONSTRUCTION

#### Housing

- Heavy-gauge aluminum for extra strength with prepunched mounting holes.
- Neoprene isolators for reduction of vibration and sound.
- Cover easily removed for quick access to motor compartment.
- Enclosed, ventilated motor compartment isolates motor from exhaust air.
- Water tight conduit tube for easy electrical connection.
- Disconnect is standard.
- Lifting lugs for easy and safe placement on roof.
- Stainless steel exterior fasteners.

#### Centrifugal Wheel

- All aluminum backward inclined wheel.
- Nonoverloading for safe operation in ducted systems.
- Dynamically balanced for smooth operation.

#### Speed Controllable Motors

- Standard motors are single speed, speed controllable and drip-proof.
- All motors are rated for continuous duty.
- Disconnect is standard with single speed drip-proof motors.
- Motors ship mounted as standard.

### DIMENSIONAL DATA

MODEL STXD	A	B	C	D	ROOF OPENING	Average Ship Wt. Lbs.
6	18.1	25.3	28.6	20.3	13 1/2	90
7	18.1	25.3	28.6	20.3	13 1/2	89
8	18.1	25.3	28.6	20.3	13 1/2	98
10	18.1	25.3	28.6	20.3	13 1/2	114
12	20.1	26.9	31.3	21.9	15 1/2	118
14	20.1	26.9	31.3	21.9	15 1/2	117
15	24.1	27.6	36.5	22.6	19 1/2	135
16	24.1	27.6	36.5	22.6	19 1/2	136

### ACCESSORIES

MODEL STXD	12" HIGH MOUNTING CURB		GRAVITY DAMPER		DAMPER MOTOR (LOOSE)	115 VOLT SPEED CONTROL	230 VOLT SPEED CONTROL
	OD	STOCK NO.	OD	STOCK NO.	STOCK NO.	STOCK NO.	STOCK NO.
6	16 1/2	711216 ●	12	411012 ●	411611 ●	2727.1 ●	3232.1 ◆
7	16 1/2	711218 ●	12	411012 ●	411611 ●	2727.1 ●	3232.1 ◆
8	16 1/2	711216 ●	12	411012 ●	411611 ●	2727.1 ●	3232.1 ◆

Sizes 6-8 are not suitable for Restaurant applications

MODEL STXD-RHUL	12" HIGH MOUNTING CURB		18" OR 24" HIGH MOUNTING CURB		GRAVITY DAMPER*	DAMPER MOTOR (LOOSE)	115 VOLT SPEED CONTROL		230 VOLT SPEED CONTROL	HINGED BASE KIT	METAL GREASE BOX
	OD	STOCK NO.	STOCK NO.	OD	STOCK NO.	STOCK NO.	STOCK NO.	STOCK NO.	STOCK NO.	STOCK NO.	STOCK NO.
10	16 1/2	711216 ●	722416V ● (24")	12	411012 ●	411611 ●	2727.1 ●	N/A	3232.1 ◆	400252	90005891-A ●
12	18 1/2	711218 ●	722418V ● (24")	14	411014 ●	411611 ●	2727.1 ●	2828.1 ●	3232.1 ◆	400252	90005891-A ●
14	18 1/2	711218 ●	722418V ● (24")	14	411014 ●	411611 ●	2727.1 ●	N/A	3232.1 ◆	400252	90005891-A ●
15	22 1/2	711222 ●	721822V ● (18")	18	411018 ●	411611 ●	N/A	2828.1 ●	3232.1 ◆	400252	90005891-A ●
16	22 1/4	711222 ●	721822V ● (18")	18	411018 ●	411611 ●	N/A	2828.1 ●	3232.1 ◆	400252	90005891-A ●

\*You can not use a damper or birdscreen in a grease application

ALL DIMENSIONS IN INCHES, WEIGHTS IN POUNDS. OD IS OUTSIDE DIMENSION OF SQUARE CURB AND DAMPER. DUE TO CONTINUING RESEARCH, S&P RESERVES THE RIGHT TO CHANGE SPECIFICATIONS WITHOUT NOTICE.

Please refer to the General Catalog or contact the Factory for our Full Line of products available on standard shipping schedules.

### AMCA SEAL



S&P USA Ventilation Systems, LLC., Div. of Soler & Palau Ventilation Group, certifies that the Models STXD shown herein are licensed to bear the AMCA Seal. The ratings shown are based on test and procedures performed in accordance with AMCA Publication 211 and AMCA Publication 311 and comply with the requirement of the AMCA Certified Ratings Program.



LISTED POWER ROOF VENTILATOR  
UL STANDARD 705 (sizes 6-8)  
UL STANDARD 762 (sizes 10-15)

### SPEED CONTROL

#### Solid State Speed Control:

Control is matched to the motor and blower wheel to allow continuous reduction in performance allowing adjustments of airflow for system balancing. CFM is reduced in direct proportion to motor speed reduction. Speed control is only available for single phase. Exhauster performance can be controlled from the ventilated area.

**727.1 MAX 1/3 HP-5 AMP 120V**  
**2828.1 MAX 1/2 HP-10 AMP 120V**

Ship Schedules:
● Next Day Shipment From Stock
▲ 3 Day Shipment From Stock
◆ 10 Day Shipment

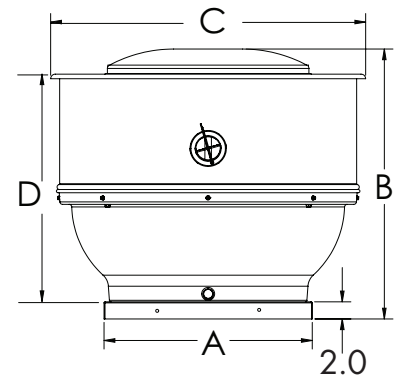

Curb Cap adaptors are available to match old style TXD and competitors curb caps. Refer to Optisizer2 for sizes available on Quickship.



**ACCESSORIES CONTINUED**

MODEL STXD/ STXDRHUL	CURB CAP ADAPTOR (replace TXD with STXD using existing curb)	WALL MOUNT ADAPTOR	BIRDSCREEN* (Ships loose)	GREASE GRABBER (roof mounting only)	GREASE GRABBER (sidewall mounting only)
	STOCK NO.	STOCK NO.	STOCK NO.	STOCK NO.	STOCK NO.
6	CCA1816 ●	400555 ●	400248 ●	-	-
7	CCA1816 ●	400555 ●	400248 ●	-	-
8	CCA1816 ●	400555 ●	400248 ●	-	-
10	CCA1816 ●	400555 ●	400248 ●	708971 ●	708971W ●
12	CCA2024 ●	400557 ●	400249 ●	708971 ●	708971W ●
14	N/A	400557 ●	400249 ●	708971 ●	708971W ●
15	N/A	400559 ●	400250 ●	708971 ●	708971W ●
16	N/A	400559 ●	400250 ●	708971 ●	708971W ●

Ship Schedules:
● Next Day Shipment From Stock
▲ 3 Day Shipment From Stock
◆ 10 Day Shipment

\*You can not use a damper or birdscreen in a grease application

<b>MODEL STXD</b>		<b>Upblast Direct Drive Centrifugal Roof/Sidewall Exhauster</b>												Ventilator with Open Drip-proof Motor				
Model STXD	Motor Hp	Max. BHp	RPM	Sones @ 1/8 SP	CFM at Static Pressure										115/1/60		208-230/1/60	
					0	1/8	1/4	3/8	1/2	5/8	3/4	7/8	1	Stock No.	Stock No.			
6	1/10	.05	1650	7.1	225	208	191	172	149	115	56	-	-	STXD06CJH1AS ●	STXD06CJH1CS ◆			
	1/10	.05	1650	7.2	308	285	259	231	194	133	68	-	-	STXD06JH1AS ●	STXD06JH1CS ◆			
7	1/10	.04	1650	7.1	437	394	345	287	223	145	80	-	-	STXD07JH1AS ●	STXD07JH1CS ◆			
8	1/25	.04	1150	6.0	612	531	427	-	-	-	-	-	-	STXD08MH1AS ●	-			
	1/4	.14	1750	10.9	935	881	832	773	712	636	536	312	-	STXD08MH1AS ●	STXD08MH1CS ◆			
10	1/4	.12	1150	7.7	979	886	777	657	452	-	-	-	-	STXD10RHULMM1AS ●	STXD10RHULMM1CS ◆			
	1/3	.28	1700	13.8	1445	1385	1319	1248	1175	1100	1015	922	809	STXD10RHULPH1AS ●	STXD10RHULPH1CS ◆			
12	1/4	.15	1150	8.5	1284	1155	1031	883	701	-	-	-	-	STXD12RHULMM1AS ●	STXD12RHULMM1CS ◆			
	1/2	.40	1700	15.3	1918	1831	1751	1665	1574	1485	1387	1282	1168	STXD12RHULQH1AS ●	STXD12RHULQH1CS ◆			
14	1/4	.26	1100	12.4	2148	1998	1830	1651	1411	1077	-	-	-	STXD14RHULMM1AS ◆	STXD14RHULMM1CS ◆			
15	1/2	.39	1150	14.0	2643	2501	2384	2215	2048	1887	1670	1298	-	STXD15RHULQM1AS ◆	STXD15RHULQM1CS ◆			
16	1/2	.49	1150	14.4	3187	3043	2904	2749	2577	2383	2154	1877	-	STXD16RHULQM1AS ◆	STXD16RHULQM1CS ◆			

Speed (RPM) shown is nominal. Performance is based on actual speed of test.  
 Performance certified is for installation type A-free inlet, free outlet.  
 Performance ratings do not include the effects of birdscreen in the airstream.

The sound ratings shown are the loudness values in the fan sones @ 5' (1.5m) in an hemispherical free field calculated per AMCA Standard 301.  
 Installation Type A: free inlet hemispherical sone levels.

# MODEL STXB-RHUL

## UPBLAST BELT DRIVE CENTRIFUGAL ROOF/SIDEWALL EXHAUSTER FOR RESTAURANT AND GENERAL EXHAUST



### APPLICATION

Isolation of motor and drive components from the air stream and the high velocity vertical air discharge make the model STXB-UL762 ideally suited for the removal of dirty, contaminated and/or high temperature air from processes and buildings. Typical applications include restaurant hoods and similar kitchen exhaust ventilation, fume and smoke removal, laboratory fume hood exhaust and chemical process exhaust.

For grease removal applications the fan must be installed per NFPA 96 and with a 40" discharge height and hinged access base.

### CONSTRUCTION

#### Housing

- Heavy-gauge aluminum for extra strength with prepunched mounting holes.
- Neoprene isolators for reduction of vibration and sound.
- Enclosed, ventilated motor/drive compartment isolates motor and drives from exhaust air.
- Cover easily removed for quick access to motor compartment.
- Water tight conduit tube for easy electrical connection.
- External weather proof disconnect is included on standard models.
- Lifting lugs for easy and safe placement on roof.
- Stainless steel exterior fasteners.

#### Centrifugal Wheel

- All aluminum backward inclined wheel.
- Nonoverloading for safe operation in ducted systems.
- Dynamically balanced for smooth operation.

#### Drives

- Sized for minimum 150% of drive horsepower.
- Machined cast iron adjustable motor pulleys.
- Adjustable base for belt tensioning.
- Nonstatic oil resistant v-belts.

### DIMENSIONAL DATA

MODEL STXB-RHUL	A	B	C	D	ROOF OPENING	Average Ship Wt. Lbs.
8	18 1/8	29 1/3	28 5/8	24 1/3	13 1/2	123
10	18 1/8	29 1/3	28 5/8	24 1/3	13 1/2	124
12	20 1/8	30 7/8	31 1/3	25 7/8	15 1/2	136
14	20 1/8	30 7/8	31 1/3	25 7/8	15 1/2	138
15	24 1/8	31 3/8	36 1/2	26 5/8	19 1/2	155
16	24 1/8	31 3/8	36 1/2	26 5/8	19 1/2	155
18	30 1/5	32 7/10	42 3/5	30 1/2	22 1/5	187
20	30 1/5	38 3/5	46 2/5	33 3/10	22 1/5	189
22	30 1/5	38 3/5	46 2/5	33 3/10	22 1/5	190
24	36	49 3/16	50	38 1/2	31 1/2	290

#### Motors

- Single speed open drip-proof are standard.
- All motors are rated for continuous duty.
- 182T and larger motors shipped unmounted for field installation.
- Disconnect switch standard with single speed drip-proof motors.

#### Bearings

- Heavy-duty ball bearing type.
- Prelubricated and permanently sealed.

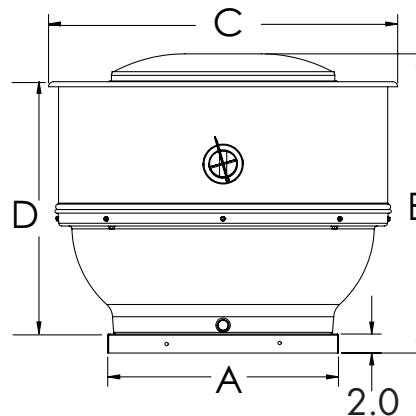

Ship Schedules:	
●	Next Day Shipment From Stock
▲	3 Day Shipment From Stock
◆	10 Day Shipment

### AMCA SEAL



S&P USA Ventilation Systems, LLC., Div. of Soler & Palau Ventilation Group, certifies that the Models STXB shown herein are licensed to bear the AMCA Seal. The ratings shown are based on test and procedures performed in accordance with AMCA Publication 211 and AMCA Publication 311 and comply with the requirement of the AMCA Certified Ratings Program.



LISTED POWER ROOF VENTILATOR  
UL STANDARD 762

ALL DIMENSIONS IN INCHES, WEIGHTS IN POUNDS. OD IS OUTSIDE DIMENSION OF SQUARE CURB AND DAMPER. DUE TO CONTINUING RESEARCH, S&P RESERVES THE RIGHT TO CHANGE SPECIFICATIONS WITHOUT NOTICE.

Please refer to the General Catalog or contact the Factory for our Full Line of products available on standard shipping schedules.

## ACCESSORIES

MODEL STXB- RHUL	12" HIGH MOUNTING CURB (1)		18" HIGH MOUNTING CURB	DAMPER (2)		DAMPER MOTOR (LOOSE)	AUTOMATIC BELT TENSIONER (INSTALLED)	HINGED BASE KIT	METAL GREASE BOX
	OD	STOCK NO.	STOCK NO.	OD	STOCK NO.	STOCK NO.	STOCK NO.	STOCK NO.	STOCK NO.
8	16 1/2	711216 ●	721816V ●	12	411012 ●	411611 ●	100069 ●	400252 ●	90005891-A ●
10	16 1/2	711216 ●	721816V ●	12	411012 ●	411611 ●	100069 ●	400252 ●	90005891-A ●
12	18 1/2	711218 ●	721818V ●	14	411014 ●	411611 ●	100070 ●	400252 ●	90005891-A ●
14	18 1/2	711218 ●	721818V ●	14	411014 ●	411611 ●	100070 ●	400252 ●	90005891-A ●
15	22 1/2	711222 ●	721822V ●	18	411018 ●	411611 ●	100070 ●	400252 ●	90005891-A ●
16	22 1/2	711222 ●	721822V ●	18	411018 ●	411611 ●	100070 ●	400252 ●	90005891-A ●
18	28 1/2	711228 ●	721828V ●	24	411024 ●	411611 ●	100072 ●	400252 ●	90005891-B ●
20	28 1/2	711228 ●	721828V ●	24	411024 ●	411611 ●	100072 ●	400252 ●	90005891-B ●
22	28 1/2	711228 ●	721828V ●	24	411024 ●	411611 ●	100072 ●	400252 ●	90005891-B ●
24	34-1/2	711234 ◆	721834V ◆	30	411030 ◆	411611 ◆	100072 ◆	400252 ◆	90005891-A ◆

1 - RESTAURANT CURBS MUST BE 18" HIGH MINIMUM PER NFPA-96.

2 - DO NOT USE DAMPER FOR FANS IN GREASE REMOVAL APPLICATIONS PER NFPA 96.

MODEL STXB	CURB CAP ADAPTOR (replace TXB with STXB using existing curb)	WALL MOUNT ADAPTOR	BIRDSCREEN (3) (Ships loose)	GREASE GRABBER	GREASE GRABBER FOR WALL
	STOCK NO.	STOCK NO.	STOCK NO.	STOCK NO.	STOCK NO.
8	CCA1816 ●	400555 ●	400248 ●	708971 ●	708971W ●
10	CCA1816 ●	400555 ●	400248 ●	708971 ●	708971W ●
12	CCA2024 ●	400557 ●	400249 ●	708971 ●	708971W ●
14	N/A	400557 ●	400249 ●	708971 ●	708971W ●
15	N/A	400559 ●	400250 ●	708971 ●	708971W ●
16	N/A	400559 ●	400250 ●	708971 ●	708971W ●
18	N/A	N/A	400276 ●	708971 ●	708971W ●
20	N/A	N/A	400277 ●	708971 ●	708971W ●
22	N/A	N/A	400277 ●	708971 ●	708971W ●
24	N/A	N/A	400278 ◆	708971 ◆	708971W ◆

3 - DO NOT USE FOR UL762 APPLICATIONS

Curb Cap adaptors are available to match old style TXB and competitors curb caps. Refer to Optisizer2 for sizes available on Quickship.

<b>MODEL STXB-UL762</b>					<b>Upblast Belt Drive Centrifugal Restaurant Roof Exhauster</b>						Ventilator with Open Drip-proof Motor and Drive Assembly	
Model STXB	Motor Hp	Max. BHP	RPM	Sones @ 1/4 SP	CFM at Static Pressure						115/1/60*	208-230/460/3/60
					0	1/4	1/2	3/4	1	1-1/4	Stock No.	Stock No.
8	1/4	0.13	1,550	9.0	833	714	560	-	-	-	STXB08RHULML1S ●	STXB08RHULML3S ▲
	1/4	0.19	1,750	11.5	940	837	720	544	-	-	STXB08RHULMM1S ●	STXB08RHULMM3S ▲
	1/4	0.26	1,950	13.5	1047	955	855	732	505	-	STXB08RHULMH1S ●	STXB08RHULMH3S ▲
	1/3	0.33	2100	15.0	1128	1041	951	850	705	-	STXB08RHULPH1S ●	STXB08RHULPH3S ▲
10	1/4	0.26	1600	12.9	1342	1198	1044	864	-	-	STXB10RHULMH1S ●	STXB10RHULMH3S ▲
	1/3	0.37	1800	15.4	1510	1384	1252	1106	934	571	STXB10RHULPH1S ●	STXB10RHULPH3S ●
12	1/4	0.26	1450	11.8	1602	1417	1213	958	-	-	STXB12RHULMH1S ●	STXB12RHULMH3S ▲
	1/3	0.35	1600	13.8	1768	1599	1431	1221	950	-	STXB12RHULPH1S ●	STXB12RHULPH3S ▲
	1/2	0.5	1800	16.5	1989	1840	1698	1520	1331	1086	STXB12RHULQH1S ●	STXB12RHULQH3S ●
14	1/4	0.24	1050	9.0	2122	1847	1472	-	-	-	STXB14RHULMH1S ●	STXB14RHULMH3S ▲
	1/3	0.36	1200	11.9	2425	2191	1895	1506	-	-	STXB14RHULPH1S ●	STXB14RHULPH3S ▲
	1/2	0.52	1350	15.0	2728	2525	2289	1987	-	-	STXB14RHULQH1S ●	STXB14RHULQH3S ●
	3/4	0.78	1550	19.1	3132	2960	2763	2537	2269	1947	STXB14RHULRH1S ●	STXB14RHULRH3S ●
	1	1.03	1700	22.0	3435	3280	3105	2917	2688	2439	STXB14RHULSH1S ●	STXB14RHULSH3S ●
15	1/4	0.26	1000	8.6	2302	1998	1627	-	-	-	STXB15RHULMH1S ●	STXB15RHULMH3S ▲
	1/3	0.34	1100	10.2	2533	2260	1953	1519	-	-	STXB15RHULPH1S ●	STXB15RHULPH3S ▲
	1/2	0.5	1250	13.3	2878	2644	2383	2079	1641	-	STXB15RHULQH1S ●	STXB15RHULQH3S ●
	3/4	0.78	1450	17.8	3338	3143	2921	2693	2423	2085	STXB15RHULRH1S ●	STXB15RHULRH3S ●
	1	1.05	1600	21.0	3684	3510	3311	3107	2895	2638	STXB15RHULSH1S ●	STXB15RHULSH3S ●
16	1/4	0.26	900	9.3	2555	2201	1740	-	-	-	STXB16RHULMH1S ●	STXB16RHULMH3S ●
	1/3	0.35	1000	10.9	2839	2524	2152	1511	-	-	STXB16RHULPH1S ●	STXB16RHULPH3S ●
	1/2	0.55	1150	14.0	3265	2994	2699	2334	1687	-	STXB16RHULQH1S ●	STXB16RHULQH3S ●
	3/4	0.79	1300	17.8	3691	3453	3202	2919	2579	2051	STXB16RHULRH1S ●	STXB16RHULRH3S ●
	1	0.99	1400	21.0	3975	3755	3524	3276	2988	2645	STXB16RHULSH1S ●	STXB16RHULSH3S ●
18	1/3	0.37	800	9.9	3194	2770	2271	-	-	-	STXB18RHULPH1S ●	STXB18RHULPH3S ●
	1/2	0.52	900	12.4	3593	3213	2816	2203	-	-	STXB18RHULQH1S ●	STXB18RHULQH3S ●
	3/4	0.83	1,050	16.2	4191	3865	3546	3179	2626	-	STXB18RHULRH1S ●	STXB18RHULRH3S ●
	1	1.09	1,150	18.5	4591	4292	4001	3690	3325	2751	STXB18RHULSH1S ●	STXB18RHULSH3S ●
	1-1/2	1.57	1,300	22.2	5189	4925	4664	4407	4121	3800	STXB18RHULTH1S ●	STXB18RHULTH3S ●
	2	2.12	1,450	26.7	5788	5551	5316	5085	4852	4590	STXB18RHULVH1S ●	STXB18RHULVH3S ●
20	1/3	0.29	650	7.3	3276	2698	1804	-	-	-	STXB20RHULPH1S ▲	STXB20RHULPH3S ▲
	1/2	0.54	800	11.5	4032	3578	3063	2291	-	-	STXB20RHULQH1S ▲	STXB20RHULQH3S ▲
	3/4	0.77	900	14.1	4536	4133	3700	3173	-	-	STXB20RHULRH1S ▲	STXB20RHULRH3S ▲
	1	1.05	1,000	16.4	5040	4675	4296	3889	3367	-	STXB20RHULSH1S ▲	STXB20RHULSH3S ▲
	1-1/2	1.59	1,150	20.1	5796	5474	5165	4817	4459	4010	STXB20RHULTH1S ▲	STXB20RHULTH3S ▲
	2	2.2	1,300	24.7	6552	6265	5994	5704	5396	5081	STXB20RHULVH1S ▲	STXB20RHULVH3S ▲
22	1/3	0.32	550	7.6	4517	3408	-	-	-	-	STXB22RHULPH1S ▲	STXB22RHULPH3S ▲
	1/2	0.54	650	10.3	5338	4434	3355	-	-	-	STXB22RHULQH1S ▲	STXB22RHULQH3S ▲
	3/4	0.83	750	13.5	6160	5400	4503	-	-	-	STXB22RHULRH1S ▲	STXB22RHULRH3S ▲
	1	1.01	800	15.3	6570	5868	5063	4198	-	-	STXB22RHULSH1S ▲	STXB22RHULSH3S ▲
	1-1/2	1.68	950	20.9	7802	7216	6571	5874	4950	-	STXB22RHULTH1S ▲	STXB22RHULTH3S ▲
	2	2.28	1,050	24.8	8624	8092	7536	6929	6242	5569	STXB22RHULVH1S ▲	STXB22RHULVH3S ▲
24	1/3	0.27	450	6.4	4368	3067	-	-	-	-	STXB24RHULPH1S ▲	STXB24RHULPH3S ▲
	1/2	0.49	550	10.2	5339	4386	-	-	-	-	STXB24RHULQH1S ▲	STXB24RHULQH3S ▲
	3/4	0.81	650	15.0	6309	5553	4533	-	-	-	STXB24RHULRH1S ▲	STXB24RHULRH3S ▲
	1	1.01	700	17.3	6795	6107	5217	-	-	-	STXB24RHULSH1S ▲	STXB24RHULSH3S ▲
	1-1/2	1.51	800	21.0	7765	7171	6471	5608	-	-	-	STXB24RHULTH3S ▲
	2	2.14	900	24.8	8736	8207	7637	6941	6133	-	-	STXB24RHULVH3S ▲

Power ratings (BHP) do not include transmission losses.

Performance certified is for installation type A-free inlet, free outlet. Performance ratings do not include the effects of birdscreen in the airstream.

The sound ratings shown are loudness values in fan sones @ 5' (1.5m) in a hemispherical free field calculated per AMCA Standard 301.

Installation Type A: free inlet hemispherical sone levels.

\*Tri-voltage (115-208-230) is standard on 3/4 through 1 1/2 Hp Single phase motors. Tri-voltage is available for the 1/2 Hp motors. Inquire for price and delivery.

Please refer to the General Catalog or contact the Factory for our Full Line of products available on standard shipping schedules.

# MODEL CWD

## DIRECT DRIVE CENTRIFUGAL SIDEWALL EXHAUSTER



### APPLICATION

Models CWD are used to exhaust relatively clean air from a variety of industrial, commercial and institutional buildings such as machinery and equipment rooms, storage areas, office buildings, restaurants, retail stores, schools and similar buildings.

The nonoverloading centrifugal wheel with its high static pressure capability, makes it suitable for either ducted or nonducted applications.

The spun aluminum exterior provides a pleasing appearance, weather proof construction and resistance to corrosion. The low silhouette design is less noticeable on the building exterior and the removable dome provides easy access to the fan interior for service and cleaning.

Direct drive units use smaller diameter wheels, resulting in low sound levels and quiet operation. They have no belts or fan bearings to maintain or adjust and consequently require very little maintenance.

### CONSTRUCTION

#### Housing

- Spun aluminum dome for weather protection and attractive appearance.
- Ventilated motor compartment with motor out of air stream for long trouble-free service.
- Dome easily removes for access to motor compartment.
- Weather-tight construction with aluminum birdscreen.
- Round duct connection provided at wheel inlet.

#### Centrifugal Wheel

- Nonoverloading backward inclined for safe operation in ducted systems.
- Statically and dynamically balanced for smooth, quiet operation.

#### Motors

- Speed controllable motors available on most models.
- Single speed open drip-proof are standard.
- Plug disconnect switch standard with single speed drip-proof motors.

### ACCESSORIES

#### Solid State Speed Control:

Control is matched to the motor and blower wheel to allow continuous reduction in performance allowing adjustments of airflow for system balancing. CFM is reduced in direct proportion to motor speed reduction. Speed control is only available for single phase. Exhauster performance can be controlled from the ventilated area.

### AMCA SEAL



S&P USA Ventilation Systems, LLC, Div. of Soler & Palau Ventilation Group, certifies that the Models CWD shown herein are licensed to bear the AMCA Seal. The ratings shown are based on test and procedures performed in accordance with AMCA Publication 211 and AMCA Publication 311 and comply with the requirement of the AMCA Certified Ratings Program.



LISTED POWER ROOF VENTILATOR  
UL STANDARD 705

### DIMENSIONAL DATA

MODEL CWD	A	B	C	D	E	G	Average Ship Wt. Lbs.
7	15	8	5 5/16	1 1/2	8	8	15
8	20	9	9 15/16	2	12	11	25
9	26	13 1/2	11 15/16	3	15	14	37
10	26	13 1/2	11 15/16	3	15	14	37
12	30	15 1/2	13 15/16	3	17 1/2	14	50
14	36	16 1/2	17 15/16	4	22	18	84

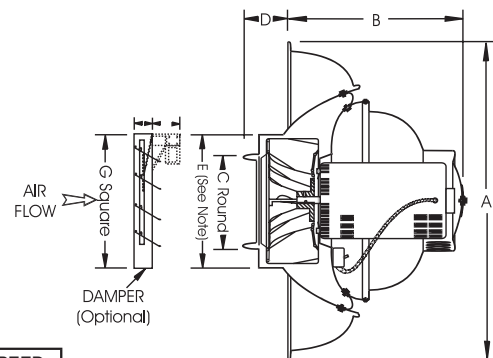

### ACCESSORIES

MODEL CWD	RECOMMENDED GRAVITY DAMPER		DAMPER MOTOR (LOOSE)	115 VOLT SPEED CONTROL	230 VOLT SPEED CONTROL
	OD	STOCK NO.	STOCK NO.	STOCK NO.	STOCK NO.
7	8 x 8	411008 ●	411611 ●	2727.1 ●	N/A
8	11 x 11	411011 ●	411611 ●	2727.1 ●	N/A
9	14 x 14	411014 ●	411611 ●	2727.1 ●	3232.1 ◆
10	14 x 14	411014 ●	411611 ●	2727.1 ●	3232.1 ◆
12	14 x 14	411014 ●	411611 ●	2727.1 ●	3232.1 ◆
14	18 x 18	411018 ●	411611 ●	2828.1 ●	3232.1 ◆

Ship Schedules:
● Next Day Shipment From Stock
▲ 3 Day Shipment From Stock
◆ 10 Day Shipment

**SPEED CONTROL 2727.1 MAX 1/3 HP-5 AMP 120V**  
**2828.1 MAX 1/2 HP-10 AMP 120V**

ALL DIMENSIONS IN INCHES, WEIGHTS IN POUNDS.  
DUE TO CONTINUING RESEARCH, S&P RESERVES THE RIGHT TO CHANGE SPECIFICATIONS WITHOUT NOTICE.

Please refer to the General Catalog or contact the Factory for our Full Line of products available on standard shipping schedules.

<b>MODEL CWD</b>		<b>Direct Drive Centrifugal Sidewall Exhauster</b>												Ventilator with Open Drip-proof Motor		
Model CWD	Motor Hp	Max. BHp	RPM	Sones @ 1/8 SP	CFM at Static Pressure										115/1/60	208-230/1/60
					0	1/8	1/4	3/8	1/2	5/8	3/4	7/8	1	Stock No.	Stock No.	
7	1/25	0.04	1550	5.9	254	220	179	127	66	-	-	-	-	CWD07HH1AS ●	N/A	
8	1/15	0.07	1550	11.4	524	463	390	320	249	186	132	-	-	CWD08IH1AS ●	N/A	
9	1/4	0.12	1140	6.4	898	755	564	390	221	-	-	-	-	CWD09MM1AS ●	CWD09MM1CS ♦	
	1/4	0.26	1550	11.4	1221	1126	1009	894	771	645	545	-	-	CWD09MH1AS ●	CWD09MH1CS ♦	
10	1/3	0.33	1575	15.4	1453	1355	1252	1118	921	785	663	548	433	CWD10PH1AS ●	CWD10PH1CS ♦	
12	1/4	0.26	1100	10.6	1583	1393	1195	995	813	618	410	193	-	CWD12MM1AS ●	CWD12MM1CS ♦	
14	1/2	0.50	1080	15.7	2585	2454	2281	2040	1722	1433	1170	906	670	CWD14QM1AS ●	CWD14QM1CS ♦	

Speed (RPM) shown is nominal. Performance is based on actual speed of test.  
Performance certified is for installation type A-free inlet, free outlet.  
Performance ratings include the effects of birdscreens in the airstream.

The sound ratings shown are the loudness values in the fan sones @ 5' (1.5m)  
in an hemispherical free field calculated per AMCA Standard 301.  
Installation Type A: free inlet hemispherical sone levels.

Ship Schedules:
● Next Day Shipment From Stock
▲ 3 Day Shipment From Stock
♦ 10 Day Shipment

<b>Performance Data at Reduced Speed</b>														
Model CWD	Motor Hp	Max. BHp	RPM	Sones @ 1/8 SP	CFM at Static Pressure									
					0	1/8	1/4	3/8	1/2	5/8	3/4	7/8	1	
7-1550	1/25	0.02	930	1.5	152	84	-	-	-	-	-	-	-	-
		0.02	1230	3.4	202	156	93	-	-	-	-	-	-	-
8-1550	1/15	0.02	930	3.5	320	209	98	-	-	-	-	-	-	-
		0.05	1225	6.4	421	339	251	167	-	-	-	-	-	-
9-1075	1/4	0.03	685	1.9	540	258	-	-	-	-	-	-	-	-
		0.08	940	4.3	741	554	330	-	-	-	-	-	-	-
9-1625	1/4	0.09	1030	5.6	811	651	467	313	-	-	-	-	-	
10-1625	1/3	0.10	1030	7.2	950	794	540	357	173	-	-	-	-	
12-1075	1/4	0.07	685	3.6	986	670	365	-	-	-	-	-	-	
		0.15	900	7.0	1296	1058	816	589	340	-	-	-	-	
14-1140	1/2	0.14	685	6.7	1640	1382	913	498	-	-	-	-	-	
		0.30	900	11.0	2154	1987	1730	1346	1028	711	390	-	-	

Model in reduced speed table indicates size and motor RPM of base unit.  
Performance is for that base unit operated at a reduced speed using the solid state speed control accessory.

AMCA Seal for sound rating does not apply to units with speed control.

Use 5 AMP Speed Control for motors 1/3 HP and smaller.  
Use 10 AMP Speed Control for motors 1/2.



# MODEL KSFV

## BELT DRIVE CENTRIFUGAL KITCHEN SUPPLY FAN

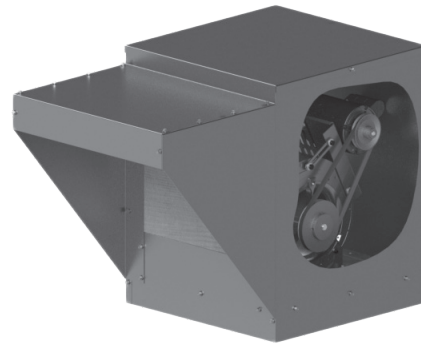

### APPLICATION

Models KSFV fans are primarily used for filtered make-up air in kitchen hood applications but may also be specified for make-up air in commercial and industrial applications such as manufacturing and assembly areas.

Model KSFV's rugged design with heavy-gauge galvanized construction provides maximum weather protection, long life and the utmost in performance efficiency. The forward curved centrifugal blower provides efficient air flow at low sound levels.

Filters are washable and are reusable to reduce maintenance costs. Quick release hood latches make routine cleaning and maintenance fast and easy.

### CONSTRUCTION

#### Blower

- Statically and dynamically balanced forward curved wheel.
- Prepunched mounting holes.
- Conduit opening for wiring from below unit.
- Disconnect switch is standard equipment.

#### Hood

- Heavy-gauge galvanized steel.
- Insulated for sound absorption and moisture barrier.
- 1 inch washable aluminum mesh filters.

#### Drives

- Machined cast iron adjustable motor pulleys standard through 3 HP.
- Pivoting motor plate for belt tensioning.
- Static resistant v-belts.

### Bearings

- Heavy-duty ball bearing type.
- Prelubricated and permanently sealed.

### Motors

- Open drip-proof construction is standard.
- Optional motor enclosures and types can be specified.

### AMCA SEAL



S&P USA Ventilation Systems, LLC., Div. of Soler & Palau Ventilation Group, certifies that the Models KSFV shown herein are licensed to bear the AMCA Seal. The ratings shown are based on test and procedures performed in accordance with AMCA Publication 211 and AMCA Publication 311 and comply with the requirement of the AMCA Certified Ratings Program.



LISTED POWER ROOF VENTILATOR  
UL STANDARD 705

### DIMENSIONAL DATA

MODEL KSFV	A	B	C	D	E	F	G SQ.	H	DAMPER O.D.	I	J	FILTERS (QTY)
9	30	23-7/8	18	25	74-1/4	22-1/2	24	24	18-1/2	10-3/8	12	20 X 20 (1)
10	35	33-7/8	18	29-3/4	74-1/4	32-1/2	34	34	28-1/2	11-5/8	13-1/4	16 X 25 (2)
12	35	33-7/8	18	29-3/4	74-1/4	32-1/2	34	34	28-1/2	13-5/8	15-3/4	16 X 25 (2)
15	35	33-7/8	18	29-3/4	74-1/4	32-1/2	34	34	28-1/2	16-1/8	18-7/8	16 X 25 (2)
18	43	41-7/8	18	30-1/8	78-1/4	40-1/2	42	42	36-1/2	19-1/8	22-1/8	20 X 25 (2)

### ACCESSORIES

MODEL KSFV	RECOMMENDED 12" HIGH MOUNTING CURB		RECOMMENDED GRAVITY DAMPER		DAMPER MOTOR (LOOSE)
	OD	STOCK NO.	OD	STOCK NO.	STOCK NO.
9	22 1/2	711222 ●	16	S3GA16CB ●	MP2781 ●
10	32-1/2	711232 ●	20	S3GA26CB ●	MP2781 ●
12	32-1/2	711232 ●	24	S3GA26CB ●	MP2781 ●
15	32-1/2	711232 ●	24	S3GA26CB ●	MP2781 ●
18	40-1/2	711240 ●	27	S3GA34CB ●	MP2781 ●

Ship Schedules:
● Next Day Shipment From Stock
▲ 3 Day Shipment From Stock
◆ 10 Day Shipment

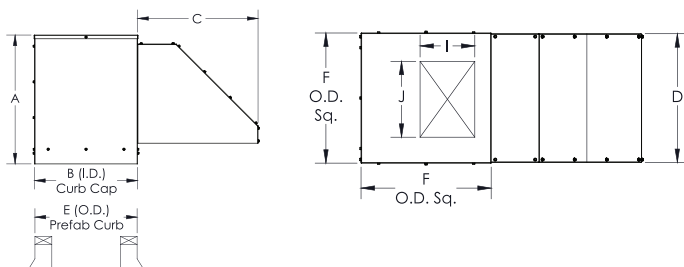

ALL DIMENSIONS IN INCHES, WEIGHTS IN POUNDS. OD IS OUTSIDE DIMENSION OF SQUARE CURB AND DAMPER. DUE TO CONTINUING RESEARCH, S&P RESERVES THE RIGHT TO CHANGE SPECIFICATIONS WITHOUT NOTICE.

*Please refer to the General Catalog or contact the Factory for our Full Line of products available on standard shipping schedules.*

# MODEL KSFV *Belt-Drive Centrifugal Kitchen Supply Fan*

Model KSFV	Motor Hp	Max BHP	STOCK NO.		CFM	Outlet Velocity	Sones @ 1/4 SP	RPM at Static Pressure															
			Single Phase 115	Three Phase 208/230/460				1/8	1/4	3/8	1/2	5/8	3/4	1	1 1/4	1 1/2	2						
9	1/4	0.25	KSFV09ML1S ● (450-600) KSFV09MM1S ● (601-850) KSFV09MH1S ● (851-1025)	KSFV09ML3S ● (450-600) KSFV09MM3S ● (601-850) KSFV09MH3S ● (851-1025)	475	534	-	466	-	-	-	-	-	-	-	-	-	-	-	-			
					575	646	-	503	-	-	-	-	-	-	-	-	-	-	-	-	-	-	
					675	758	16.5	541	661	-	-	-	-	-	-	-	-	-	-	-	-	-	-
					775	871	19.3	578	697	-	-	-	-	-	-	-	-	-	-	-	-	-	-
					875	983	22.2	623	735	826	-	-	-	-	-	-	-	-	-	-	-	-	-
					975	1,096	23.9	671	772	863	941	-	-	-	-	-	-	-	-	-	-	-	-
					1,075	1,208	26.1	719	809	901	978	1047	-	-	-	-	-	-	-	-	-	-	-
					1,175	1,320	29.1	762	851	939	1014	1083	1146	-	-	-	-	-	-	-	-	-	-
	1,275	1,433	32.5	807	898	976	1052	1121	1182	-	-	-	-	-	-	-	-	-	-				
	1/3	0.33	KSFV09PH1S ●	KSFV09PH3S ●	1,375	1,545	36.1	857	948	1015	1091	1158	1219	1330	-	-	-	-	-	-			
					1,475	1,657	39.8	910	997	1059	1127	1196	1257	1366	1464	-	-	-	-	-	-		
	1/2	0.50	KSFV09QH1S ●	KSFV09QH3S ●	1,575	1,770	43.3	962	1041	1107	1166	1232	1295	1403	1500	1592	-	-	-	-			
1,675					1,882	46.8	1016	1084	1156	1210	1270	1333	1441	1537	-	-	-	-	-	-			
3/4	0.75	KSFV09RH1S ●	KSFV09RH3S ●	1,975	2,219	62.2	1177	1228	1294	1355	1401	1447	-	-	-	-	-	-	-				
				2,075	2,331	70.6	1232	1281	1338	1404	-	-	-	-	-	-	-	-	-	-			
1	1.15	KSFV09SH1S ●	KSFV09SH3S ●	2,175	2,444	80.3	1286	1333	1383	-	-	-	-	-	-	-	-	-	-				
				2,275	2,556	91.2	1340	-	-	-	-	-	-	-	-	-	-	-	-	-	-		
10	1/4	0.25	KSFV10ML1S ● (400-500) KSFV10MH1S ● (501-675)	KSFV10ML3S ● (400-500) KSFV10MH3S ● (501-675)	950	896	5.9	409	524	629	-	-	-	-	-	-	-	-	-				
					1,090	1,028	7.0	435	540	636	726	-	-	-	-	-	-	-	-	-			
					1,230	1,160	8.4	463	561	648	733	812	887	-	-	-	-	-	-	-	-		
					1,370	1,292	10.3	494	583	666	743	819	891	-	-	-	-	-	-	-	-		
					1,510	1,425	12.7	527	608	687	760	829	897	1026	-	-	-	-	-	-	-		
					1,650	1,557	14.3	560	636	710	779	845	907	1031	1146	-	-	-	-	-	-		
	1/3	0.33	KSFV10PH1S ●	KSFV10PH3S ●	1,790	1,689	15.9	594	666	734	801	864	923	1039	1151	1255	-	-	-				
					1,930	1,821	17.7	629	697	761	823	884	941	1050	1157	1259	-	-	-				
	1/2	0.5	KSFV10QL1S ● (575-750) KSFV10QH1S ● (751-875)	KSFV10QL3S ● (751-875) KSFV10QH3S ● (751-875)	2,070	1,953	19.7	664	729	789	848	906	962	1066	1167	1266	1449	-	-				
					2,210	2,085	21.6	700	762	819	875	930	983	1085	1180	1274	1453	-	-				
	3/4	0.75	KSFV10RL1S ● (625-850) KSFV10RH1S ● (851-1000)	KSFV10RL3S ● (625-850) KSFV10RH3S ● (851-1000)	2,350	2,217	23.6	737	796	851	903	955	1006	1105	1196	1285	1459	-	-				
					2,490	2,349	25.6	774	830	883	932	982	1031	1126	1215	1300	1467	-	-				
	1	1	KSFV10SL1S ● (725-950) KSFV10SH1S ● (951-1100)	KSFV10SL3S ● (725-950) KSFV10SH3S ● (951-1100)	2,630	2,481	27.6	811	865	916	963	1010	1057	1148	1236	1318	1477	-	-				
					2,770	2,613	29.7	849	900	949	995	1040	1084	1172	1257	1337	-	-					
	1-1/2	1.5	KSFV10TL1S ● (800-970) KSFV10TM1S ● (971-1175) KSFV10TH1S ● (1176-1225)	KSFV10TL3S ● (800-970) KSFV10TM3S ● (971-1175) KSFV10TH3S ● (1176-1225)	2,910	2,745	31.7	887	935	983	1027	1070	1113	1196	1279	1358	-	-					
					3,050	2,877	33.8	925	971	1017	1060	1102	1142	1223	1301	1379	-	-					
					3,190	3,009	36.1	964	1007	1052	1094	1134	1173	1250	1326	-	-						
	2	2.3	KSFV10VH1S ●	KSFV10VH3S ●	3,330	3,142	38.5	1003	1044	1087	1127	1167	1204	1279	-	-	-						
3,470					3,274	41.0	1042	1080	1122	1161	1200	1237	-	-	-								
3,610					3,406	43.6	1081	1117	1157	-	-	-	-	-	-								
3,750					3,538	-	1120	-	-	-	-	-	-	-	-								
12	1/4	0.25	KSFV12ML1S ● (350-450) KSFV12MH1S ● (451-600)	KSFV12ML3S ● (350-450) KSFV12MH3S ● (451-600)	1,150	737	-	366	-	-	-	-	-	-	-	-	-	-					
					1,310	840	-	380	-	-	-	-	-	-	-	-	-	-					
					1,470	942	10.0	398	499	-	-	-	-	-	-	-	-	-					
					1,630	1,045	11.6	420	517	-	-	-	-	-	-	-	-						
					1,790	1,147	12.9	444	531	610	-	-	-	-	-	-	-						
					1,950	1,250	14.2	470	547	629	-	-	-	-	-	-	-						
	1/3	0.33	KSFV12PH1S ●	KSFV12PH3S ●	2,110	1,353	15.5	496	566	644	709	-	-	-	-	-							
					2,270	1,455	17.0	523	588	658	728	-	-	-	-	-							
	1/2	0.5	KSFV12QL1S ● (475-600) KSFV12QH1S ● (601-725)	KSFV12QL3S ● (475-600) KSFV12QH3S ● (601-725)	2,430	1,558	18.7	550	613	675	743	801	-	-	-	-							
					2,590	1,660	20.4	578	638	695	757	819	869	-	-	-							
	3/4	0.75	KSFV12RL1S ● (500-650) KSFV12RH1S ● (651-800)	KSFV12RL3S ● (500-650) KSFV12RH3S ● (651-800)	2,750	1,763	22.3	606	664	716	773	833	888	-	-	-							
					2,910	1,865	24.1	635	690	740	792	848	904	-	-	-							
					3,070	1,968	25.9	664	716	765	812	864	918	1013	-	-							
	1	1	KSFV12SL1S ● (575-750) KSFV12SH1S ● (751-875)	KSFV12SL3S ● (575-750) KSFV12SH3S ● (751-875)	3,230	2,071	27.7	694	743	790	835	882	932	1032	-	-							
					3,390	2,173	29.5	724	770	817	859	903	949	1046	-	-							
	1-1/2	1.5	KSFV12TL1S ● (650-775) KSFV12TM1S ● (776-950) KSFV12TH1S ● (951-1000)	KSFV12TL3S ● (650-775) KSFV12TM3S ● (776-950) KSFV12TH3S ● (951-1000)	3,550	2,276	31.5	754	797	842	884	925	968	1060	-	-							
					3,710	2,378	33.5	784	825	868	910	948	989	1075	-	-							
					3,870	2,481	35.8	814	854	895	936	973	1010	-	-	-							
2	2.3	KSFV12VL1S ● (807-1025) KSFV12VH1S ● (1026-1125)	KSFV12VL3S ● (807-1025) KSFV12VH3S ● (1026-1125)	4,030	2,583	38.0	845	883	921	962	998	-	-	-									
				4,190	2,686	40.3	876	912	949	-	-	-	-	-									
				4,350	2,788	-	906	-	-	-	-	-	-	-									

Please refer to the General Catalog or contact the Factory for our Full Line of products available on standard shipping schedules.

# MODEL KSFV Belt-Drive Centrifugal Kitchen Supply Fan

Model KSFV	Motor Hp	Max. BHP	STOCK NO.	STOCK NO.	CFM	Outlet Velocity	Sones @ 1/4 SP	RPM at Static Pressure										
			Single Phase 115	Three Phase 208/230/460				1/8	1/4	3/8	1/2	5/8	3/4	1	1 1/4	1 1/2	2	
15	3/4	0.75	KSFV15RL1S ● (375-500)	KSFV15RL3S ● (375-500)	3,130	1,519	17.1	444	495	544	587	629	673	-	-	-	-	
			KSFV15RH1S ● (501-625)	KSFV15RH3S ● (501-625)	3,345	1,624	18.7	468	515	562	605	645	684	-	-	-	-	
					3,560	1,728	20.4	492	536	581	623	662	698	775	-	-	-	
	1	1	KSFV15SL1S ● (425-550)	KSFV15SL3S ● (425-550)	3,775	1,833	22.3	517	558	600	642	680	715	785	-	-	-	
			KSFV15SM1S ● (551-650)	KSFV15SM3S ● (551-650)	3,990	1,937	24.2	542	581	620	660	698	732	798	866	-	-	
	1 1/2	1.5	KSFV15TL1S ● (561-700)	KSFV15TL3S ● (561-700)	4,205	2,041	26.2	567	604	641	679	716	750	813	877	942	-	
			KSFV15TH1S ● (701-800)	KSFV15TH3S ● (701-800)	4,420	2,146	28.0	592	627	662	699	735	768	830	890	951	-	
	2	2	KSFV15TL1S ● (561-700)	KSFV15TL3S ● (561-700)	4,635	2,250	29.9	617	651	684	719	754	786	848	905	962	-	
			KSFV15TH1S ● (701-800)	KSFV15TH3S ● (701-800)	4,850	2,354	31.9	642	675	707	740	773	805	866	921	975	-	
					5,065	2,459	34	668	700	730	761	793	824	884	938	-	-	
	18	3/4	0.75	KSFV18RH1S ●	KSFV18RH3S ●	3,650	1,259	17.3	372	421	456	494	534	571	-	-	-	-
						3,940	1,359	19.1	395	440	477	509	547	583	648	-	-	-
1		1	KSFV18SL1S ● (401-500)	KSFV18SL3S ● (401-500)	4,230	1,459	20.8	419	459	498	528	560	595	660	721	-	-	
			KSFV18SH1S ● (501-550)	KSFV18SH3S ● (501-550)	4,520	1,559	22.6	443	480	518	549	576	608	672	730	-	-	
1 1/2		1.5	KSFV18TL1S ● (476-550)	KSFV18TL3S ● (476-550)	4,810	1,659	24.7	467	501	538	570	596	623	684	741	794	-	
			KSFV18TH1S ● (551-625)	KSFV18TH3S ● (551-625)	5,100	1,759	26.7	492	522	557	591	617	641	696	753	-	-	
2		2	KSFV18VL1S ● (450-550)	KSFV18VL3S ● (450-550)	5,390	1,859	29.1	516	545	577	610	638	662	710	-	-	-	
			KSFV18VM1S ● (551-625)	KSFV18VM3S ● (551-625)	5,680	1,959	31.5	541	568	598	629	659	682	-	-	-	-	
3		3	N/A	KSFV18WL3S ● (500-600)	5,970	2,059	33.9	566	591	619	649	678	-	-	-	-	-	
				KSFV18WM3S ● (601-675)	6,260	2,159	36.7	591	615	641	-	-	-	-	-	-	-	
				KSFV18WH3S ● (676-800)	6,550	2,259	39.7	616	-	-	-	-	-	-	-	-	-	

Power ratings (BHP) do not include transmission losses.  
 Performance certified is for installation type B-free inlet, ducted outlet.  
 Performance ratings do not include the effects of appurtenances (accessories).  
 575/3/60 ODP Motors are available for most motor HP's - Refer to Price List.

Table shows fan RPM needed for required CFM and SP.  
 Shaded/Non-shaded area shows motor HP and stock number to order.

Ship Schedules:
● Next Day Shipment From Stock
▲ 3 Day Shipment From Stock
◆ 10 Day Shipment

# MODEL SQB

## SQUARE INLINE BELT DRIVE CENTRIFUGAL DUCT FAN



### APPLICATION

Model SQB square inline duct mounted fans are available in sizes 7 through 24, moving from 100 to over 9,300 CFM, with static pressure capabilities to 1-1/2". SQB units are the perfect selection for clean air applications where space is a leading consideration. The compact housing with removable access doors and side discharge capability can be mounted in any orientation. AMCA licensed performance and UL listing assure that you've made a reliable selection.

### CONSTRUCTION

#### Housing

- Heavy-gauge galvanized steel for extra strength.
- Integral inlet and outlet duct collars.
- Universal mounting - horizontal, vertical or any angle.
- Motor and drives out of the air stream.
- Easy access for service with removable side panels and drive and bearing covers without disconnecting duct.

#### Centrifugal Wheel

- All aluminum backward inclined wheel.
- Nonoverloading for safe operation in ducted systems.
- Statically and dynamically balanced for smooth operation.

#### Bearings

- Bearings designed for minimum 200,000 hour life.
- Bearings are double sealed and prelubricated with relube fittings.

#### Drives

- Sized for minimum 150% of drive horse power.
- Machined cast iron adjustable motor pulleys.
- Motor mount plate with integral belt tensioning device.
- Nonstatic v-belts.

#### Motors

- Single speed open drip-proof are standard.
- All motors are rated for continuous duty.
- Standard motors are permanently sealed ball bearing type.
- 182T and larger motors shipped unmounted for field installation.

### AMCA SEAL



S&P USA Ventilation Systems, LLC., Div. of Soler & Palau Ventilation Group, certifies that the Models SQB shown herein are licensed to bear the AMCA Seal. The ratings shown are based on test and procedures performed in accordance with AMCA Publication 211 and AMCA Publication 311 and comply with the requirement of the AMCA Certified Ratings Program.



UL-705 LISTED POWER VENTILATOR

### DIMENSIONAL DATA

MODEL SQB	A	B	C	Average Ship Wt. Lbs.
7-8	15	23	11 7/8	75
10	17	23	13 7/8	85
12	21	23	17 7/8	95
15	24	28	21 7/8	140
18	28	30	23 7/8	190
20	32	34	27 7/8	220
24	39	38	34 7/8	320

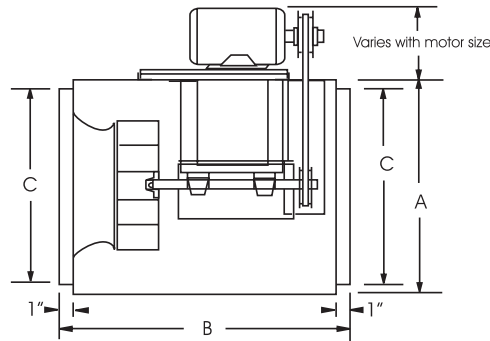

Ship Schedules:
● Next Day Shipment From Stock
▲ 3 Day Shipment From Stock
◆ 10 Day Shipment

### ACCESSORIES

MODEL SQB	GRAVITY DAMPER		DAMPER MOTOR (LOOSE)	MOTOR SAFETY GUARD	VIBRATION ISOLATORS HANGING STYLE		VIBRATION ISOLATORS FLOOR MOUNT	
	OD	STOCK NO.	STOCK NO.	STOCK NO.	RUBBER STOCK NO.	SPRING STOCK NO.	RUBBER STOCK NO.	SPRING STOCK NO.
7	12	411012 ●	411611 ●	MGSQB78 ●	VHRSQ06-15 ●	VHSSQ06-20 ●	VFRSQ06-15 ●	VFSSQ06-20 ●
8	12	411012 ●	411611 ●	MGSQB78 ●	VHRSQ06-15 ●	VHSSQ06-20 ●	VFRSQ06-15 ●	VFSSQ06-20 ●
10	14	411014 ●	411611 ●	MGSQB1012 ●	VHRSQ06-15 ●	VHSSQ06-20 ●	VFRSQ06-15 ●	VFSSQ06-20 ●
12	19	411018 ●	411611 ●	MGSQB1012 ●	VHRSQ06-15 ●	VHSSQ06-20 ●	VFRSQ06-15 ●	VFSSQ06-20 ●
15	22	411022 ●	411611 ●	MGSQB15 ●	VHRSQ06-15 ●	VHSSQ06-20 ●	VFRSQ06-15 ●	VFSSQ06-20 ●
18	24	411024 ●	411611 ●	MGSQB18 ●	VHRSQ18-20 ●	VHSSQ06-20 ●	VFRSQ18-20 ●	VFSSQ06-20 ●
20	28	411028 ●	411611 ●	MGSQB2024 ●	VHRSQ18-20 ●	VHSSQ06-20 ●	VFRSQ18-20 ●	VFSSQ06-20 ●
24	35	611035 ●	411611 ●	MGSQB2024 ●	VHRSQ24-30 ◆	VHSSQ24 ●	VFRSQ24-30 ◆	VFSSQ24-30 ●

(1) - MAXIMUM 3 HP MOTOR - FOR 5 HP MOTOR CONTACT FACTORY

ALL DIMENSIONS IN INCHES, WEIGHTS IN POUNDS. OD IS OUTSIDE DIMENSION OF SQUARE DAMPER. DUE TO CONTINUING RESEARCH, S&P RESERVES THE RIGHT TO CHANGE SPECIFICATIONS WITHOUT NOTICE.

Please refer to the General Catalog or contact the Factory for our Full Line of products available on standard shipping schedules.

<b>MODEL SQB</b>					<b>Square Inline Belt Drive Centrifugal Duct Fan</b>								Ventilator with Open Drip-proof Motor and Drive Assembly		
MODEL SQB	MOTOR Hp	MAX BHP	RPM	Sones @ 1/2 SP	CFM at Static Pressure								115/1/60*	208-230/460/3/60	
					1/8	1/4	3/8	1/2	3/4	1	1 1/4	1 1/2	STOCK NO.	STOCK NO.	
7	1/4	0.06	1210	6.1	182	138	86	-	-	-	-	-	-	SQB07ML1S ●	SQB07ML3S ▲
		0.13	1530	9.1	249	217	182	144	-	-	-	-	-	-	-
	1/4	0.11	1450	8.4	233	199	161	118	-	-	-	-	-	SQB07MH1S ●	SQB07MH3S ▲
		0.26	1930	14.3	328	304	279	252	193	123	-	-	-	-	-
	1/3	0.18	1690	10.8	281	253	223	190	114	-	-	-	-	SQB07PH1S ●	SQB07PH3S ▲
0.34		2110	17.3	362	341	319	295	243	186	116	-	-	-	-	
8	1/4	0.05	1050	4.8	453	345	-	-	-	-	-	-	-	SQB08ML1S ●	SQB08ML3S ▲
		0.17	1575	10.7	756	696	630	558	-	-	-	-	-	-	-
	1/4	0.13	1425	9.3	673	604	527	437	-	-	-	-	-	SQB08MH1S ●	SQB08MH3S ▲
		0.26	1800	13.8	880	829	774	715	583	-	-	-	-	-	-
	1/3	0.15	1500	9.9	715	651	579	500	-	-	-	-	-	SQB08PH1S ●	SQB08PH3S ▲
		0.37	2025	17.4	1001	957	910	860	753	627	-	-	-	-	-
	1/2	0.28	1850	14.6	907	858	805	748	623	-	-	-	-	SQB08QH1S ●	SQB08QH3S ●
0.55		2325	23.0	1160	1124	1084	1043	955	860	753	604	-	-	-	
10	1/4	0.09	1050	5.1	798	687	540	-	-	-	-	-	-	SQB10MH1S ●	SQB10MH3S ▲
		0.26	1500	10.0	1219	1143	1068	988	787	-	-	-	-	-	-
	1/3	0.12	1175	6.6	917	821	712	557	-	-	-	-	-	SQB10PH1S ●	SQB10PH3S ▲
		0.34	1650	11.9	1356	1286	1216	1148	992	763	-	-	-	-	-
	1/2	0.23	1450	9.4	1173	1095	1016	932	702	-	-	-	-	SQB10QH1S ●	SQB10QH3S ●
		0.53	1900	16.0	1581	1520	1461	1401	1278	1139	957	-	-	-	-
	3/4	0.38	1700	12.7	1401	1334	1267	1200	1053	857	-	-	-	SQB10RH1S ●	SQB10RH3S ●
0.79		2175	21.0	1827	1773	1720	1669	1564	1456	1336	1194	-	-	-	
12	1/4	0.12	900	5.4	1293	1098	769	-	-	-	-	-	-	SQB12MH1S ●	SQB12MH3S ▲
		0.26	1170	9.3	1773	1639	1491	1312	-	-	-	-	-	-	-
	1/3	0.18	1025	6.9	1518	1359	1165	806	-	-	-	-	-	SBQ12PH1S ●	SQB12PH3S ▲
		0.34	1275	11.3	1954	1833	1704	1558	1099	-	-	-	-	-	-
	1/2	0.23	1120	8.4	1686	1544	1384	1177	-	-	-	-	-	SQB12QH1S ●	SQB12QH3S ●
		0.53	1475	15.1	2296	2192	2085	1973	1710	1282	-	-	-	-	-
	3/4	0.39	1325	12.3	2040	1924	1801	1667	1297	-	-	-	-	SQB12RH1S ●	SQB12RH3S ●
		0.78	1675	18.4	2633	2543	2450	2356	2151	1906	1545	-	-	-	-
	1	0.59	1525	15.9	2380	2280	2178	2070	1827	1481	-	-	-	SQB12SH1S ●	SQB12SH3S ●
1.05		1850	22.0	2926	2844	2762	2678	2501	2306	2074	1751	-	-	-	

Performance certified is for installation Type B-free inlet, ducted outlet.  
 Power ratings (BHP) do not include transmission losses.  
 Performance ratings do not include the effects of appurtenances (accessories).

The sound ratings shown are loudness values in fan sones at 5 feet (1.5m) in a hemispherical free field calculated per AMCA Standard 301. Installation Type A: free inlet hemispherical sone levels.

Performance at higher RPM for each horse power is standard for that unit. Reduced performance can be obtained down to the minimum shown at the lower RPM for each unit, by resetting the adjustable motor sheave.

\*Tri-voltage (115-208-230) is standard on 3/4 through 1 1/2 Hp Single phase motors. Tri-voltage is available for the 1/2 Hp motors. Inquire for price and delivery.

Ship Schedules:
● Next Day Shipment From Stock
▲ 3 Day Shipment From Stock
◆ 10 Day Shipment

<b>MODEL SQB</b>					<b>Square Inline Belt Drive Centrifugal Duct Fan</b>								<b>Ventilator with Open Drip-proof Motor and Drive Assembly</b>			
MODEL SQB	MOTOR Hp	MAX BHP	RPM	Sones @ 1/2 SP	CFM at Static Pressure								115/160*	208-230/460/3/60		
					1/8	1/4	3/8	1/2	3/4	1	1 1/4	1 1/2	STOCK NO.	STOCK NO.		
15	1/4	0.14	770	-	1611	1408	1135	-	-	-	-	-	-	SQB15MH1S ●	SQB15MH3S ▲	
		0.26	950	7.7	2071	1911	1745	1548	-	-	-	-	-	-	-	-
	1/3	0.17	825	-	1753	1567	1349	-	-	-	-	-	-	SQB15PH1S ●	SQB15PH3S ▲	
		0.36	1060	10.2	2347	2203	2058	1904	1464	-	-	-	-	-	-	-
	1/2	0.29	990	8.6	2172	2018	1861	1684	-	-	-	-	-	SQB15QH1S ●	SQB15QH3S ●	
		0.53	1205	13.5	2707	2577	2452	2324	2038	1576	-	-	-	-	-	-
	3/4	0.41	1105	11.1	2459	2320	2182	2038	1674	-	-	-	-	SQB15RH1S ●	SQB15RH3S ●	
		0.78	1375	17.2	3124	3009	2897	2787	2559	2298	1925	-	-	-	-	-
	1	0.47	1160	12.4	2595	2462	2331	2197	1884	-	-	-	-	SQB15SH1S ●	SQB15SH3S ●	
		1.08	1530	21	3502	3396	3295	3196	2996	2786	2545	2225	-	-	-	-
	1 1/2	0.91	1445	18.8	3295	3184	3078	2973	2760	2526	2236	1585	-	SQB15TH1S ●	SQB15TH3S ●	
		1.57	1735	26	3999	3904	3813	3724	3549	3372	3187	2983	-	-	-	-
18	1/3	0.24	700	5.9	2395	2155	1888	1443	-	-	-	-	-	SQB18PH1S ●	SQB18PH3S ▲	
		0.36	800	7.6	2803	2592	2378	2135	-	-	-	-	-	-	-	-
	1/2	0.24	700	5.9	2395	2155	1888	1443	-	-	-	-	-	SQB18QH1S ●	SQB18QH3S ●	
		0.56	925	10.2	3306	3119	2938	2752	2301	-	-	-	-	-	-	-
	3/4	0.30	750	6.7	2600	2376	2141	1845	-	-	-	-	-	SQB18RH1S ●	SQB18RH3S ●	
		0.76	1025	12.6	3704	3531	3367	3204	2851	2364	-	-	-	-	-	-
	1	0.43	850	8.5	3005	2805	2607	2393	1662	-	-	-	-	SQB18SH1S ●	SQB18SH3S ●	
		1.07	1150	15.9	4198	4039	3890	3745	3450	3119	2673	-	-	-	-	-
	1 1/2	0.66	975	11.3	3505	3326	3154	2981	2589	1754	-	-	-	SQB18TH1S ●	SQB18TH3S ●	
		1.55	1300	20.0	4786	4642	4507	4376	4120	3854	3562	3202	-	-	-	-
	2	0.94	1100	14.6	4000	3837	3682	3531	3217	2846	2189	-	-	SQB18VH1S ▲	SQB18VH3S ●	
		2.04	1425	23.0	5275	5140	5014	4893	4657	4422	4176	3906	-	-	-	-
20	1/3	0.29	575	5.5	3297	2923	2428	-	-	-	-	-	-	SQB20PH1S ●	SQB20PH3S ▲	
		0.35	610	5.6	3539	3195	2778	2028	-	-	-	-	-	-	-	-
	1/2	0.29	575	5.5	3297	2923	2428	-	-	-	-	-	-	SQB20QH1S ●	SQB20QH3S ●	
		0.52	700	8.3	4151	3862	3546	3167	-	-	-	-	-	-	-	-
	3/4	0.33	600	6.3	3470	3118	2683	-	-	-	-	-	-	SQB20RH1S ●	SQB20RH3S ●	
		0.78	800	11.6	4819	4571	4311	4028	3286	-	-	-	-	-	-	-
	1	0.42	650	6.7	3813	3496	3134	2646	-	-	-	-	-	SQB20SH1S ●	SQB20SH3S ●	
		1.06	885	14.5	5380	5158	4929	4688	4134	3286	-	-	-	-	-	-
	1 1/2	0.89	835	12.9	5051	4814	4568	4305	3661	-	-	-	-	SQB20TH1S ●	SQB20TH3S ●	
		1.57	1010	19.0	6199	6005	5809	5607	5173	4665	3963	-	-	-	-	-
	2	0.97	860	13.7	5216	4987	4750	4498	3904	2801	-	-	-	SQB20VH1S ▲	SQB20VH3S ●	
		2.09	1110	23.0	6849	6673	6496	6315	5938	5523	5038	4388	-	-	-	-
24	1/2	0.42	530	5.5	4426	3956	3416	2395	-	-	-	-	-	SQB24QH1S ●	SQB24QH3S ●	
		0.54	580	7.1	4928	4502	4049	3485	-	-	-	-	-	-	-	-
	3/4	0.42	530	5.5	4426	3956	3416	2395	-	-	-	-	-	SQB24RH1S ●	SQB24RH3S ●	
		0.80	660	9.9	5720	5343	4966	4558	3307	-	-	-	-	-	-	-
	1	0.52	570	6.8	4828	4394	3928	3325	-	-	-	-	-	SQB24SH1S ●	SQB24SH3S ●	
		1.07	725	12.6	6356	6010	5670	5319	4488	-	-	-	-	-	-	-
	1 1/2	0.80	660	9.9	5720	5343	4966	4558	3307	-	-	-	-	SQB24TH1S ●	SQB24TH3S ●	
		1.59	830	17.2	7375	7066	6768	6471	5843	5076	-	-	-	-	-	-
	2	0.86	675	10.5	5867	5498	5131	4738	3653	-	-	-	-	SQB24VH1S ▲	SQB24VH3S ●	
		2.11	910	21.0	8145	7859	7584	7314	6763	6156	5400	-	-	-	-	-
	3	2.04	900	20.0	8049	7760	7483	7210	6650	6030	5237	-	-	-	-	-
		3.10	1035	26.0	9340	9084	8838	8598	8122	7632	7101	6486	-	-	N/A	SQB24WH3S ●

Performance certified is for installation Type B-free inlet, ducted outlet.  
 Power ratings (BHP) do not include transmission losses.  
 Performance ratings do not include the effects of appurtenances (accessories).

The sound ratings shown are loudness values in fan sones at 5 feet (1.5m) in a hemispherical free field calculated per AMCA Standard 301. Installation Type A: free inlet hemispherical sone levels.

Performance at higher RPM for each horse power is standard for that unit. Reduced performance can be obtained down to the minimum shown at the lower RPM for each unit, by resetting the adjustable motor sheave.

\*Tri-voltage (115-208-230) is standard on 3/4 through 1 1/2 Hp Single phase motors.  
 Tri-voltage is available for the 1/2 Hp motors. Inquire for price and delivery.

Ship Schedules:
● Next Day Shipment From Stock
▲ 3 Day Shipment From Stock
◆ 10 Day Shipment

Please refer to the General Catalog or contact the Factory for our Full Line of products available on standard shipping schedules.



# MODEL SQD

## SQUARE INLINE DIRECT DRIVE CENTRIFUGAL DUCT FAN

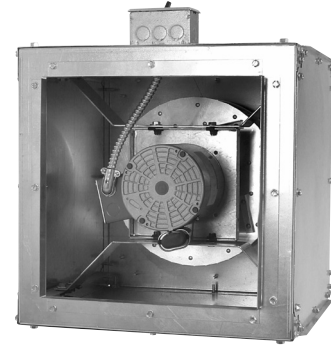

### APPLICATION

Model SQD square inline duct mounted fans are available in sizes 6 through 15, moving up to 2,800 CFM, with static pressure capabilities to 1". SQD units are the perfect selection for clean air applications where space is a leading consideration. The compact housing with removable access doors and side discharge capability can be mounted in any orientation. AMCA licensed performance and UL listing assure that you have made a reliable selection.

### CONSTRUCTION

#### Housing

- Heavy-gauge galvanized steel for extra strength.
- Integral inlet and outlet duct collars
- Universal mounting - horizontal, vertical or any angle.
- Easy access for service with removable side panels, without disconnecting duct.

#### Centrifugal Wheel

- All aluminum backward inclined wheel.
- Nonoverloading for safe operation in ducted systems.
- Statically and dynamically balanced for smooth operation.
- SQD 06 has composite wheel.

### Motors

- Single speed totally enclosed are standard.
- All motors are rated for continuous duty.
- Standard motors are permanently sealed ball bearing type.
- SQD06 has an external rotor motor.

### AMCA SEAL



S&P USA Ventilation Systems, LLC., Div. of Soler & Palau Ventilation Group, certifies that the Models SQD shown herein are licensed to bear the AMCA Seal. The ratings shown are based on test and procedures performed in accordance with AMCA Publication 211 and AMCA Publication 311 and comply with the requirement of the AMCA Certified Ratings Program.



UL-705 LISTED POWER VENTILATOR

### DIMENSIONAL DATA

MODEL SQD	A	B	C	Average Ship Wt. Lbs.
6	13	14	8 7/8	30
8	16	17	11 7/8	60
10	19	20	13 7/8	75
12	23	24	15 7/8	90
15	28	29	19 7/8	120

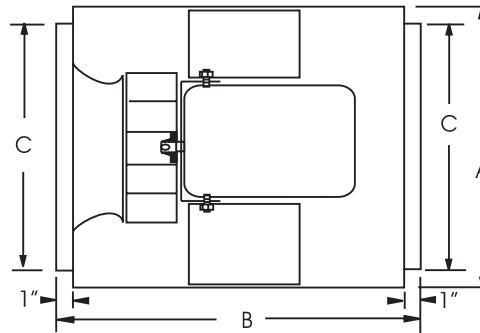

### ACCESSORIES

MODEL SQD	DAMPER		DAMPER MOTOR (LOOSE) STOCK NO.	VIBRATION ISOLATORS HANGING STYLE		VIBRATION ISOLATORS FLOOR MOUNT		SPEED CONTROL		
	OD	STOCK NO.		RUBBER STOCK NO.	SPRING STOCK NO.	RUBBER STOCK NO.	SPRING STOCK NO.	115/1/60		230/1/60
								5 AMP STOCK NO.	10 AMP STOCK NO.	STOCK NO.
6	9	411009 ●	411611 ●	VHRSQ06-15 ●	VHSSQ06-20 ●	VFRSQ06-15 ●	VFSSQ06-20 ●	2727.1 ●	N/A	N/A
8	12	411012 ●	411611 ●	VHRSQ06-15 ●	VHSSQ06-20 ●	VFRSQ06-15 ●	VFSSQ06-20 ●	2727.1 ●	N/A	3232.1 ◆
10	14	411014 ●	411611 ●	VHRSQ06-15 ●	VHSSQ06-20 ●	VFRSQ06-15 ●	VFSSQ06-20 ●	2727.1 ●	2828.1 ●	3232.1 ◆
12	16	411016 ●	411611 ●	VHRSQ06-15 ●	VHSSQ06-20 ●	VFRSQ06-15 ●	VFSSQ06-20 ●	2727.1 ●	2828.1 ●	3232.1 ◆
15	20	411020 ▲	411611 ▲	VHRSQ06-15 ▲	VHSSQ06-20 ▲	VFRSQ06-15 ▲	VFSSQ06-20 ▲	N/A	2828.1 ●	3232.1 ◆

**SPEED CONTROL**      **2727.1 MAX 1/3 HP-5 AMP 120V**  
**2828.1 MAX 1/2 HP-10 AMP 120V**

Ship Schedules:
● Next Day Shipment From Stock
▲ 3 Day Shipment From Stock
◆ 10 Day Shipment

ALL DIMENSIONS IN INCHES, WEIGHTS IN POUNDS. OD IS OUTSIDE DIMENSION OF SQUARE DAMPER. DUE TO CONTINUING RESEARCH, S&P RESERVES THE RIGHT TO CHANGE SPECIFICATIONS WITHOUT NOTICE.

*Please refer to the General Catalog or contact the Factory for our Full Line of products available on standard shipping schedules.*

<b>MODEL SQD</b>					<b>Square Inline Direct Drive Centrifugal Duct Fan</b>							<b>Ventilator with Totally Enclosed Motor</b>	
MODEL SQD	MOTOR Hp	MAX BHp	RPM	SONES @ 1/4 SP	CFM at Static Pressure							115/1/60*	208-230/1/60*
					1/8	1/4	3/8	1/2	5/8	3/4	1	STOCK NO.	STOCK NO.
60	100 WATT	.95 MAX AMPS @ 115/60/1	1250	2.2	162	102	-	-	-	-	-	SQD601AS ●	N/A
			1500	3.5	208	174	116	-	-	-	-		
			1850	5.4	269	245	215	170	130	-	-		
			2100	6.8	312	290	268	240	201	158	-		
			2400	8.6	362	343	324	304	281	250	176		
			2700*	10.4	406	389	372	355	337	316	257		
825	1/4	0.18	1050	3.8	398	276	-	-	-	-	-	SQD8251AS ●	SQD8251CS ◆
			1200	5.4	482	388	259	-	-	-	-		
			1400	7.2	588	514	427	313	-	-	-		
			1550	8.5	665	600	528	444	335	-	-		
			1740*	10.5	763	706	646	580	504	412	-		
1025	1/4	0.16	900	4.5	692	514	-	-	-	-	-	SQD10251AS ▲	SQD10251CS ◆
			1000	6.0	804	651	434	-	-	-	-		
			1050	6.8	858	714	547	-	-	-	-		
			1150*	8.3	964	836	698	473	-	-	-		
1050	1/2	0.38	1050	6.0	845	703	524	-	-	-	-	SQD10501AS ●	SQD10501CS ◆
			1200	8.1	1000	883	748	584	-	-	-		
			1350	10.1	1151	1050	940	815	667	-	-		
			1450	11.2	1250	1158	1058	949	826	680	-		
			1650	13.9	1445	1366	1283	1194	1098	993	740		
			1710*	14.7	1505	1430	1350	1266	1175	1078	852		
1225	1/4	0.19	900	6.0	1051	809	529	-	-	-	-	SQD12251AS ▲	SQD12251CS ◆
			1000	7.6	1216	1003	774	-	-	-	-		
			1050	8.4	1297	1096	883	640	-	-	-		
			1100	9.3	1377	1187	986	767	-	-	-		
			1120*	9.7	1410	1224	1028	817	-	-	-		
1250	1/2	0.55	950	6.4	1129	920	654	-	-	-	-	SQD12501AS ●	SQD12501CS ◆
			1050	7.8	1287	1106	890	651	-	-	-		
			1300	11.9	1673	1526	1380	1215	1020	825	-		
			1500	15.6	1975	1844	1719	1591	1451	1292	950		
			1620*	17.7	2159	2033	1918	1802	1680	1548	1237		
1550	1/2	0.51	700	6.1	1517	1174	793	-	-	-	-	SQD15501AS ▲	SQD15501CS ◆
			800	8.0	1839	1515	1233	833	-	-	-		
			900	10.2	2152	1849	1585	1335	994	-	-		
			1000	12.7	2456	2178	1924	1695	1469	1187	-		
			1060*	14.6	2658	2399	2151	1928	1719	1501	-		

\* True motor speed - other speeds based on speed control use.

Performance certified is for installation Type B-free inlet, ducted outlet.  
 Power ratings (BHP) do not include transmission losses.  
 Performance ratings do not include the effects of appurtenances (accessories).

Ship Schedules:
● Next Day Shipment From Stock
▲ 3 Day Shipment From Stock
◆ 10 Day Shipment

The sound ratings shown are loudness values in fan sones at 5 feet (1.5m) in a hemispherical free field calculated per AMCA Standard 301. Installation Type A: free inlet hemispherical sone levels.

Use 5 AMP Speed Control for motors 1/3 HP and smaller.  
 Use 10 AMP Speed Control for motors 1/2.

# MODEL TRC

## TOTAL RECOVERY FOR ALL CLIMATES

### COMMERCIAL APPLICATIONS

S&P's TRCs moderate extremes in both temperature and humidity, creating a comfortable indoor environment. The unique moisture transfer capability of the S&P core also eliminates condensation and frost build up in most applications. No mechanical or electrical defrost systems are needed, which means higher heat recovery efficiencies, easier installation and more reliable operation.

#### Standard Specifications and Features

- For indoor use
- TRC800 is available in horizontal and vertical configurations; TRC500, TRC1200, and TRC1600 available in horizontal configurations only
- MERV-8 filters (2 in the TRC500 & TRC800, 4 in the TRC1200 & TRC1600)
- Transformer/relay package allowing simple on/off control
- Access doors for easy access to blowers, core and filters
- TRC500 & TRC800 have integral mounting flange and hanging bracket system
- TRC1200 & TRC1600 have mounting feet for installation at floor level
- 2 Direct Drive, TEFC, Premium Efficient blower motors in the TRC500, TRC800, & TRC1200
- 2 Belt Drive, TEFC, Premium Efficient blower motors in the TRC1600
- Fully insulated case with large cores for high efficiency
- No condensate pan or drain required
- 10-year industry best core warranty
- 2-year warranty on balance of unit
- AHRI certified performance data for efficiency and cross leakage.
- UL tested flammability and smoke generation that meets NFPA 90A and 90B test standards for commercial applications.



#### TRC Controls

Stock No.	Control	Description
STC7D-W ●	Digital Time Clock - Wall Mount	<ul style="list-style-type: none"> <li>• Up to 8 on/off cycles per day or 56 per week</li> <li>• 24 VAC power requirement</li> <li>• Battery back-up</li> <li>• Fits any 4" x 4" electrical box</li> </ul>
SMC-C ●	Motion (Occupancy) Control - Ceiling Mount	<ul style="list-style-type: none"> <li>• Passive infrared sensor</li> <li>• Adjustable time-off delay to 30 minutes</li> <li>• 24 VAC power requirement</li> <li>• Covers up to 1500 sq. ft. floor space <i>walking motion coverage up to 22 foot radius</i></li> </ul>
SCO2-W ●	Carbon Dioxide Control - Wall Mount	<ul style="list-style-type: none"> <li>• Adjustable control from 600-2000 PPM</li> <li>• Digital display</li> <li>• 24 VAC power requirement</li> <li>• Computer/BAS interface for information and control</li> <li>• Self calibrates during periods of low occupancy</li> </ul>

These controls are intended to turn S&P commercial energy recovery ventilation systems on and off at appropriate times. Specification, installation and set-up is an easy process. The TRC units come standard with a 24 volt transformer/relay package for easy interface with all controls.

It is not necessary that S&P controls be used to operate S&P units. A wide range of controls or building automation systems may be used. Additionally, TRC800 units are "VFD Ready" as a standard feature.

The S&P residential (TR) units have their own line of compatible controls that are not intended to operate S&P commercial (TRC) units.

Ship Schedules:
● Next Day Shipment From Stock

Please refer to the General Catalog or contact the Factory for our Full Line of products available on standard shipping schedules.

# Model TRC500



## Performance

Airflow CFM	ESP in H <sub>2</sub> O	Watts	Temp EFF%	Total EFF% Winter/Summer*
225	1.25	335	81	76/66
338	1.00	420	77	71/61
380	0.90	470	75	69/59
450	0.65	550	73	66/56
540	0.25	640	70	62/52
575	0.00	690	69	61/51
600	-0.25	735	68	60/50

\* At AHRI 1060 standard conditions  
(see certified data in full TR/TRC brochure for core components.)  
Note: Watts is for the entire unit.

## Specifications

Ventilation Type: Static Plate, Heat and Humidity Transfer						
Typical Airflow Range: 200-540 CFM						
AHRI 1060 Certified Core: One L85						
Airflow Rating Points (for AHRI): 450 CFM and 338 CFM						
Motors: One, 0.6 hp (Single Phase)						
V	Hz	Phase	FLA	Min. Cir. Amps	Max. Overcurrent Protection Device	Stock No.
115	60	Single	7.0	8.8	15	TRC500-115 ▲
208-230	60	Single	3.5	4.4	15	TRC500-230 ▲
Standard Features: Non-Fused Disconnect 24 VAC Transformer/Relay Package						
Filters: Two total, MERV 8, 2" pleated, 14" x 20" nominal size						
Weight: 141 lbs (unit), 160 lbs (in carton) 200 lbs (on pallet), up to 3 units on 40 lb pallet						
Shipping Dimensions: 48" L x 41" W x 18" H (in carton) 55" L x 42" W x 22" H (on pallet)						



Ship Schedules:
▲ 3 Day Shipment From Stock

EA: Exhaust Air to outdoors
OA: Outdoor Air intake
RA: Room Air to be exhausted
FA: Fresh Air to inside

## DIMENSIONAL DATA

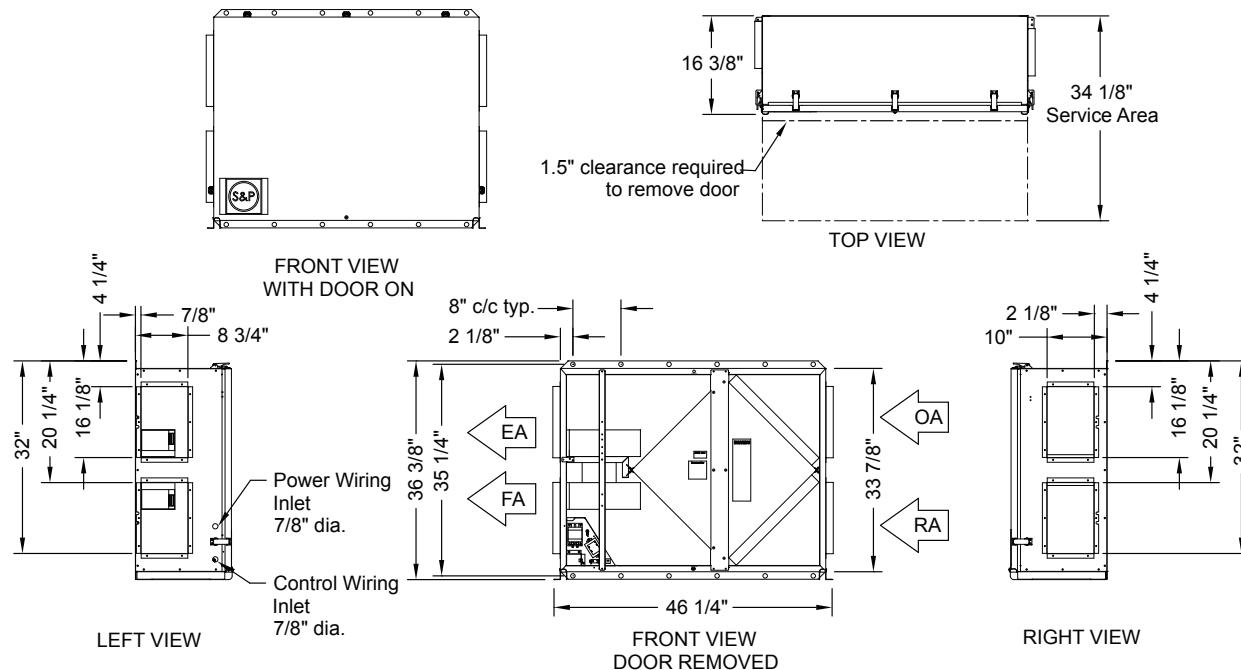

Please refer to the General Catalog or contact the Factory for our Full Line of products available on standard shipping schedules.

# Model TRC800 - Horizontal Configuration



## Performance

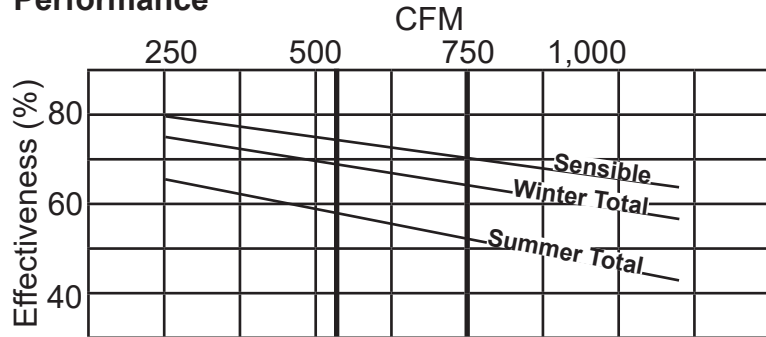

\* At AHRI 1060 standard conditions  
(see certified data in full TR/TRC brochure for core components.)

## Specifications

Ventilation Type: Static Plate, Heat and Humidity Transfer						
Typical Airflow Range: 250-925 CFM						
AHRI 1060 Certified Core: One L125-00						
Airflow Rating Points (for AHRI): 750 CFM and 563 CFM						
Number Motors: Two direct drive blower/motor packages						
V	Hz	Phase	FLA (per motor)	Min. Cir. Amps	Max. Overcurrent Protection Device	Stock No.
115	60	Single	9.0	20.3	25	TRC800-115 ▲
208-230	60	Single	4.5	10.1	15	TRC800-230 ▲
Standard Features: Non-Fused Disconnect 24 VAC Transformer/Relay Package						
Filters: Two total, MERV 8, 2" pleated, 20" x 20" nominal size						
Weight: 211 lbs (unit), 300 lbs (shipping weight, on pallet)						
Shipping Dimensions: 62" L x 48" W x 40" H						



Ship Schedules:
▲ 3 Day Shipment From Stock

## Airflow Performance

Motor HP Phase	External Static Pressure (Inches Water Column)						
	0.0	0.25	0.5	0.75	0.9	1.25	1.5
0.75	970 CFM	925 CFM	860 CFM	795 CFM	750 CFM	635 CFM	480 CFM
Single Phase	1,490 Watts	1,375 Watts	1,270 Watts	1,160 Watts	1,090 Watts	950 Watts	825 Watts

Note: Watts is for the entire unit (two motors).

## DIMENSIONAL DATA

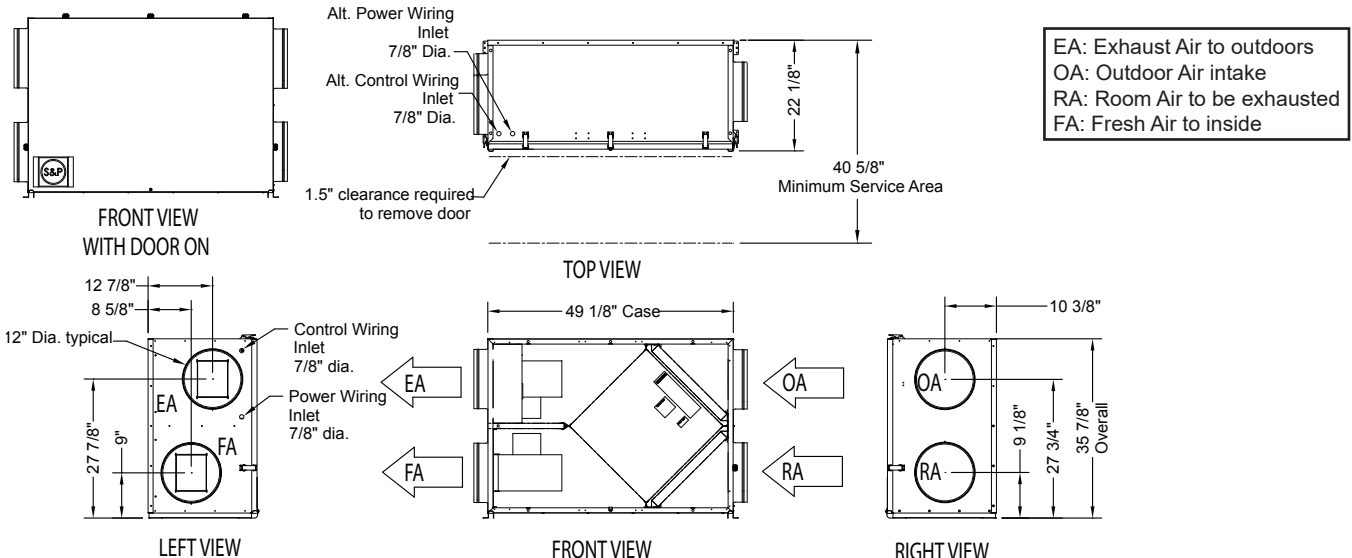

Please refer to the General Catalog or contact the Factory for our Full Line of products available on standard shipping schedules.

## Model TRC800V - Vertical Configuration



### Performance

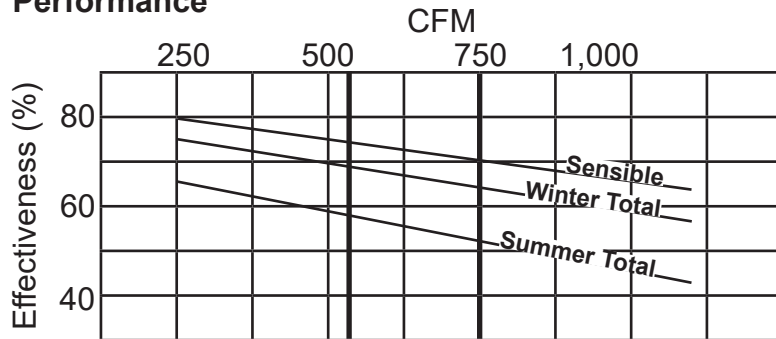

\* At AHRI 1060 standard conditions  
(see certified data in full TR/TRC brochure for core components.)

### Specifications

Ventilation Type: Static Plate, Heat and Humidity Transfer						
Typical Airflow Range: 250-925 CFM						
AHRI 1060 Certified Core: One L125-00						
Airflow Rating Points (for AHRI): 750 CFM and 563 CFM						
Number Motors: Two direct drive blower/motor packages						
V	Hz	Phase	FLA (per motor)	Min. Cir. Amps	Max. Overcurrent Protection Device	Stock No.
115	60	Single	9.0	20.3	25	TRC800-115 ▲
208-230	60	Single	4.5	10.1	15	TRC800-230 ▲
Standard Features: Non-Fused Disconnect 24 VAC Transformer/Relay Package						
Filters: Two total, MERV 8, 2" pleated, 20" x 20" nominal size						
Weight: 211 lbs (unit), 300 lbs (shipping weight, on pallet)						
Shipping Dimensions: 62" L x 48" W x 40" H						



Ship Schedules:
▲ 3 Day Shipment From Stock

### Airflow Performance

Motor HP Phase	External Static Pressure (Inches Water Column)						
	0.0	0.25	0.5	0.75	0.9	1.25	1.5
0.75	970 CFM	925 CFM	860 CFM	795 CFM	750 CFM	635 CFM	480 CFM
Single Phase	1,490 Watts	1,375 Watts	1,270 Watts	1,160 Watts	1,090 Watts	950 Watts	825 Watts



# Model TRC800V - Vertical Configuration Dimensions

EA: Exhaust Air to outdoors  
 OA: Outdoor Air intake  
 RA: Room Air to be exhausted  
 FA: Fresh Air to inside

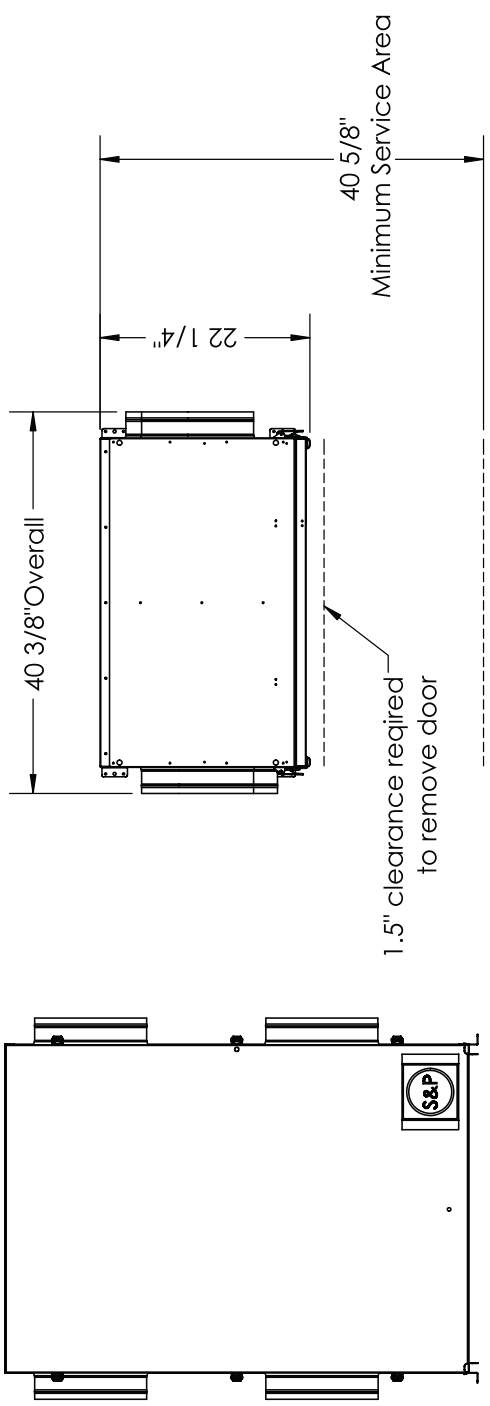

**FRONT VIEW WITH DOOR ON**

**TOP VIEW**

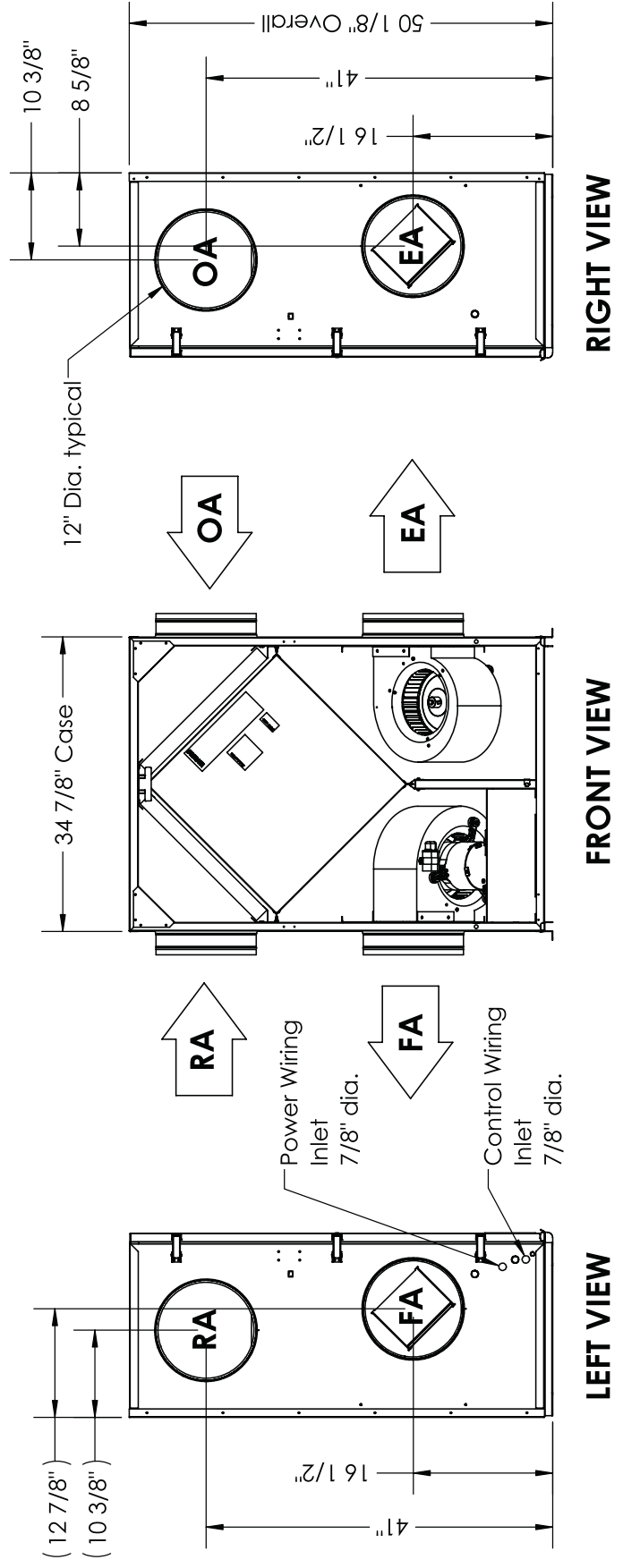

**RIGHT VIEW**

**FRONT VIEW**

**LEFT VIEW**

Please refer to the General Catalog or contact the Factory for our Full Line of products available on standard shipping schedules.

## Model TRC1200

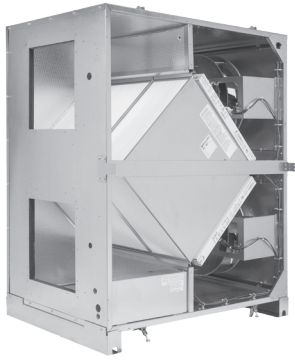

## Core Performance

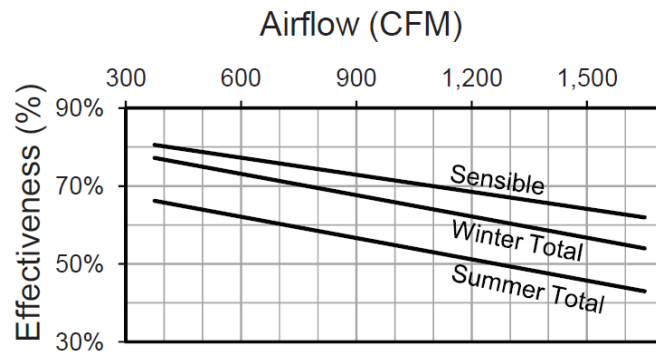

\* At AHRI 1060 standard conditions. See all AHRI certified ratings at [www.ahrinet.org](http://www.ahrinet.org).

## Specifications

Ventilation Type: Static Plate, Heat and Humidity Transfer						
Typical Airflow Range: 375-1,575 CFM						
AHRI 1060 Certified Cores: One L62-G5 and one L125-G5						
Motors: Qty 2, 1.0 HP ea., Direct Drive motorized impeller packages						
Drive HP	V	Hz	Phase	FLA (per motor)	Min. Cir. Amps	Max. Overcurrent Protection Device
1.0	120	60	Single	6.5	14.6	20
	208-230	60	Single	3.3-3.4	7.7	15
	208-230	60	Three	2.2-2.2	5.0	15
	460	60	Three	1.1	2.5	15
Standard Features: 24 VAC Transformer/Relay Package						
Filters: Total Qty. 4, MERV 8: (2) 14" x 20" x 2" and (2) 16" x 20" x 2"						
Dimensions & Weight: 45 1/8" L x 33 1/2" W x 53 5/8" H, 337 lbs.						
Shipping Dimensions & Weight (on pallet): 70" L x 47" W x 58 5/8" H, 403 lbs.						



Ship Schedules:
▲ 3 Day Shipment From Stock

EA: Exhaust Air to outdoors
OA: Outdoor Air intake
RA: Room Air to be exhausted
FA: Fresh Air to inside

## Airflow Performance

Motor HP Phase	External Static Pressure (Inches Water Column)						
	0.0	0.25	0.50	0.75	1.00	1.25	1.50
1.0 Single Phase	1,575 CFM	1,470 CFM	1,350 CFM	1,225 CFM	1,090 CFM	950 CFM	795 CFM
	1,545 Watts	1,525 Watts	1,500 Watts	1,475 Watts	1,435 Watts	1,380 Watts	1,300 Watts
1.0 Three Phase	1,675 CFM	1,570 CFM	1,435 CFM	1,280 CFM	1,115 CFM	940 CFM	760 CFM
	1,410 Watts	1,400 Watts	1,380 Watts	1,340 Watts	1,280 Watts	1,210 Watts	1,135 Watts

NOTE: Watts is for the entire unit (2 motors).

NOTE: Airflow performance includes effect of clean, standard filter supplied with unit.

**DIMENSIONAL DATA**

EA: Exhaust Air to outdoors  
 OA: Outdoor Air intake  
 RA: Room Air to be exhausted  
 FA: Fresh Air to inside

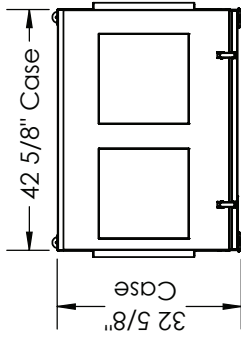

TOP VIEW

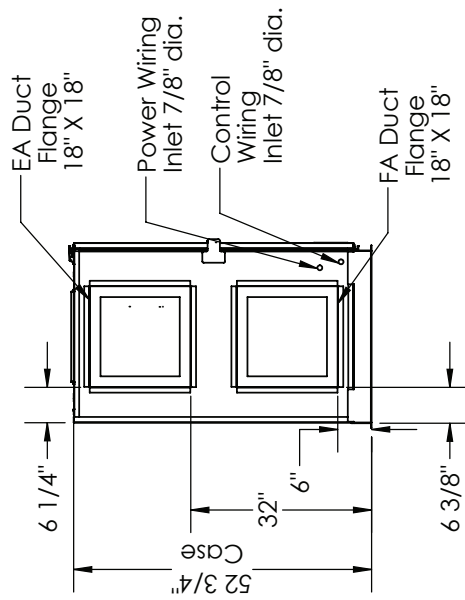

LEFT VIEW

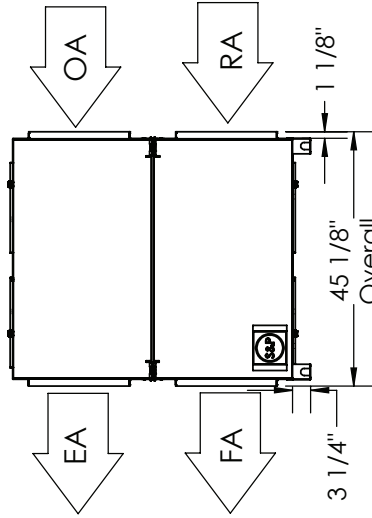

FRONT VIEW

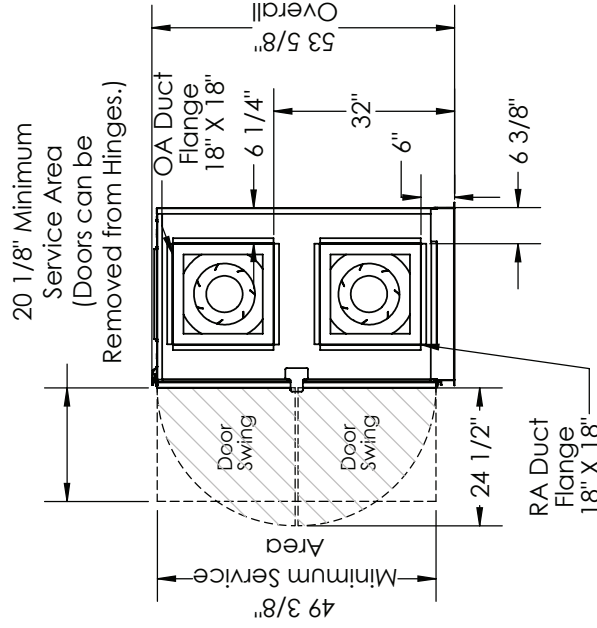

RIGHT VIEW

## Model TRC1600

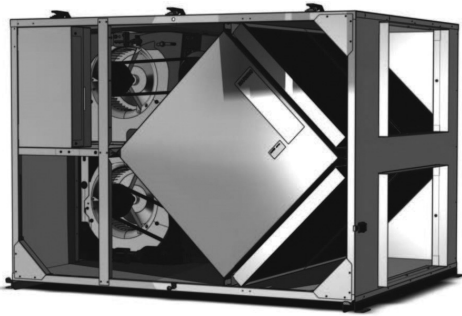

## Performance

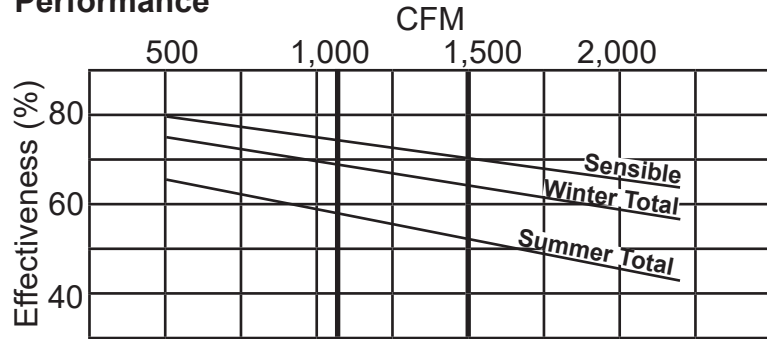

\* At AHRI 1060 standard conditions

## Specifications

Ventilation Type: Static Plate, Heat and Humidity Transfer							
Typical Airflow Range: 500-2,025 CFM							
AHRI 1060 Certified Core: Two L125-00							
Airflow Rating Points (for AHRI): 1,500 CFM and 1,126 CFM							
Number Motors: Two belt drive blower/motor packages with adjustable sheaves							
Drive HP	V	Hz	Phase	FLA (per motor)	Min. Cir. Amps	Max. Overcurrent Protection Device	Stock No.
1.5	115	60	Single	15.2	34.2	45	TRC1600-115 ▲
	208-230	60	Single	8.2-7.6	18.5	25	TRC1600-230 ▲
	208-230	60	Three	4.6-4.8	10.8	15	TRC1600-230-3P ▲
	460	60	Three	2.4	5.4	15	TRC1600-460-3P ▲
Standard Features: Totally Enclosed Premium Efficiency Motors Motor Starters, Non-fused Disconnect 24 VAC Transformer/Relay Package							
Filters: Four total, MERV 8, 2" pleated, 20" x 20" nominal size							
Weight: 414 lbs (unit), 505 lbs (shipping weight, on pallet)							
Shipping Dimensions: 72" L x 48" W x 40" H							



Ship Schedules:
▲ 3 Day Shipment From Stock

## Airflow Performance

Motor HP	Blower RPM	Turns Open	External Static Pressure (in w.g.)													
			0.0		0.25		0.5		0.75		0.9		1.25		1.5	
			SCFM	BHP	SCFM	BHP	SCFM	BHP	SCFM	BHP	SCFM	BHP	SCFM	BHP	SCFM	BHP
1.5	1148	4	1592	0.7	1480	0.7	1320	0.6	1120	0.5	800	0.4	-	-	-	-
	1304	2	1809	1.0	1720	1.0	1600	0.9	1410	0.8	1250	0.7	975	0.6	630	0.4
	1460	0	2025	1.5	1950	1.4	1845	1.3	1715	1.2	1540	1.1	1400	1.0	1165	0.8

**DIMENSIONAL DATA**

EA: Exhaust Air to outdoors  
 OA: Outdoor Air intake  
 RA: Room Air to be exhausted  
 FA: Fresh Air to inside

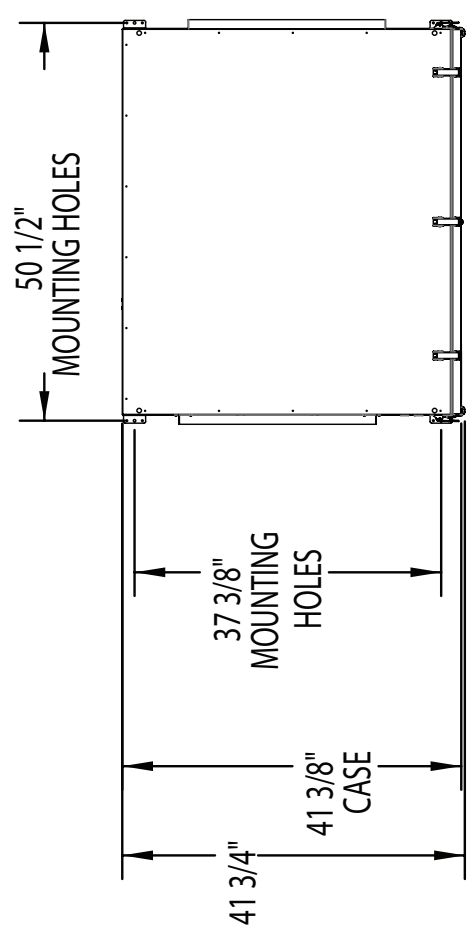

TOP VIEW

Ø 7/8" POWER WIRING

Ø 7/8" CONTROL WIRING

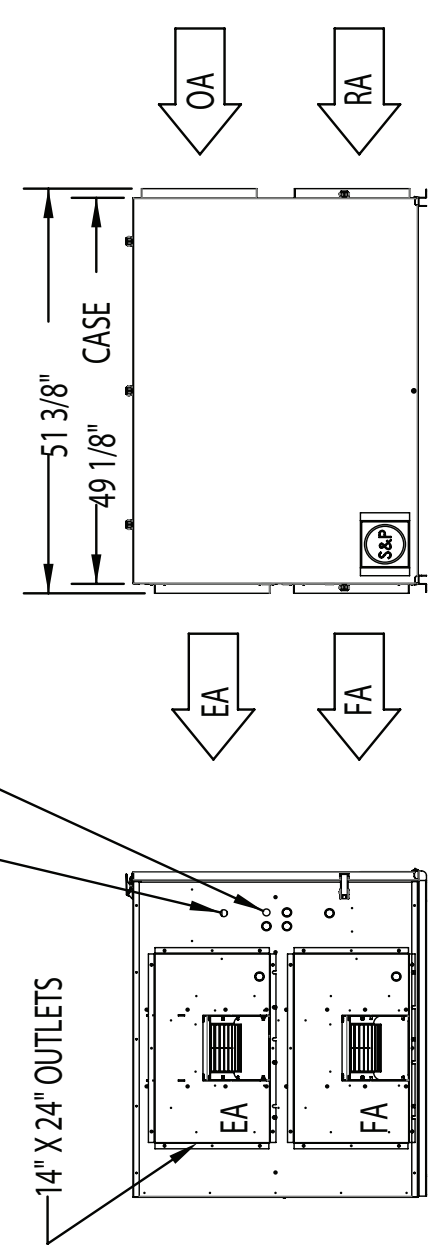

FRONT VIEW

LEFT VIEW

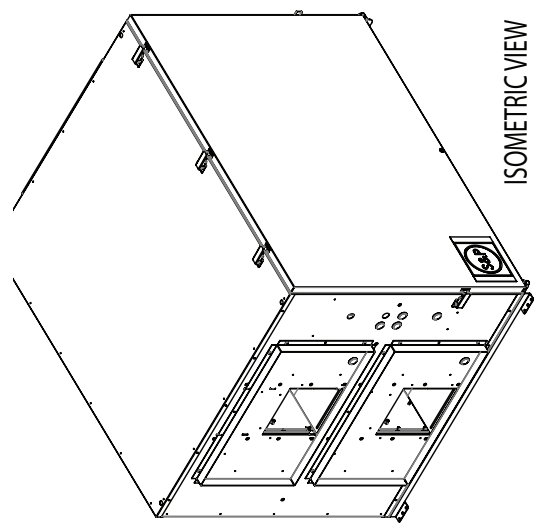

ISOMETRIC VIEW

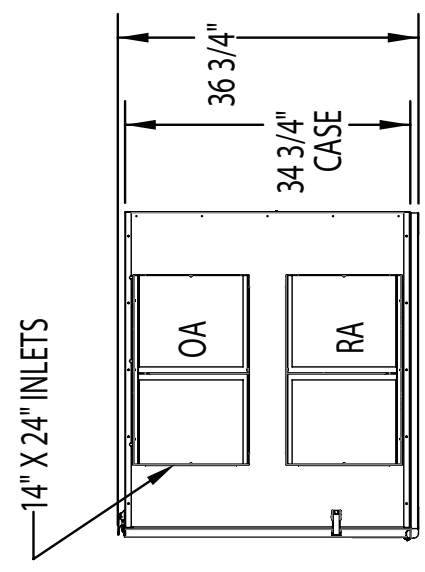

RIGHT VIEW

Please refer to the General Catalog or contact the Factory for our Full Line of products available on standard shipping schedules.

# MODEL TRCe with EC Motors

## TOTAL RECOVERY FOR ALL CLIMATES

### COMMERCIAL APPLICATIONS

S&P's TRCe, with EC motors, moderates extremes in both temperature and humidity, creating a comfortable indoor environment. The unique moisture transfer capability of the S&P core also eliminates condensation and frost build up in most applications. No mechanical or electrical defrost systems are needed, which means higher heat recovery efficiencies, easier installation and more reliable operation.



#### Standard Specifications and Features

- All TRCe models feature Electronically Commutated (EC) motors
- For indoor use
- TRCe800 is available in horizontal and vertical configurations; TRCe500 and TRCe1200 available in horizontal configurations only
- MERV-8 filters (2 in the TRCe500 & TRCe800, 4 in the TRCe1200)
- Transformer/relay package allowing simple on/off control
- Access doors for easy access to blowers, core and filters
- TRCe500 & TRCe800 have integral mounting flange and hanging bracket system
- TRCe1200 have mounting feet for installation at floor level
- Quantity 2, direct drive EC blower/motors
- Fully insulated case with large cores for high efficiency
- No condensate pan or drain required
- 10-year industry best core warranty
- 2-year warranty on balance of unit
- AHRI certified performance data for efficiency and cross leakage.
- UL tested flammability and smoke generation that meets NFPA 90A and 90B test standards for commercial applications.



#### TRCe Controls

Stock No.	Control	Description
SC-TRCe ●	Remote Potentiometer	<ul style="list-style-type: none"> <li>• Speed control</li> <li>• Remotely mounted</li> </ul>
STC7D-W ●	Digital Time Clock - Wall Mount	<ul style="list-style-type: none"> <li>• Up to 8 on/off cycles per day or 56 per week</li> <li>• 24 VAC power requirement</li> <li>• Battery back-up</li> <li>• Fits any 4" x 4" electrical box</li> </ul>
SMC-C ●	Motion (Occupancy) Control - Ceiling Mount	<ul style="list-style-type: none"> <li>• Passive infrared sensor</li> <li>• Adjustable time-off delay to 30 minutes</li> <li>• 24 VAC power requirement</li> <li>• Covers up to 1500 sq. ft. floor space</li> <li>• <i>walking motion coverage up to 22 foot radius</i></li> </ul>
SCO2-W ●	Carbon Dioxide Control - Wall Mount	<ul style="list-style-type: none"> <li>• Adjustable control from 600-2000 PPM</li> <li>• Digital display</li> <li>• 24 VAC power requirement</li> <li>• Computer/BAS interface for information and control</li> <li>• Self calibrates during periods of low occupancy</li> </ul>

These controls are intended to turn S&P commercial energy recovery ventilation systems on and off at appropriate times. Specification, installation and set-up is an easy process. The TRCe units come standard with a 24 volt transformer/relay package for easy interface with all controls.

It is not necessary that S&P controls be used to operate S&P units. A wide range of controls or building automation systems may be used.

Ship Schedules:
● Next Day Shipment From Stock

Please refer to the General Catalog or contact the Factory for our Full Line of products available on standard shipping schedules.



# Model TRCe500



## Specifications

Ventilation Type: Static Plate, Heat and Humidity Transfer					
Typical Airflow Range: 200-530 CFM					
AHRI 1060 Certified Core: One L85-G5					
Airflow Rating Points (for AHRI): 450 CFM and 338 CFM					
Motors: One, 0.5 HP, Direct Drive EC blower/motor package					
V	Hz	Phase	FLA	Min. Cir. Amps	Max. Overcurrent Protection Device
120	60	Single	8.1	10.1	15
208-230	60	Single	4.8	6.0	15
Standard Features: Non-Fused Disconnect 24 VAC Transformer/Relay Package					
Filters: Two total, MERV 8, 2" pleated, 14" x 20" nominal size					
Weight: 141 lbs (unit), 160 lbs (in carton) 200 lbs (on pallet), up to 3 units on 40 lb pallet					
Shipping Dimensions: 48" L x 41" W x 18" H (in carton) 55" L x 42" W x 22" H (on pallet)					

## Core Performance

Airflow CFM	ESP in H <sub>2</sub> O	Watts
229	0.07	75
321	0.16	171
395	0.25	284
458	0.34	410
491	0.40	506
209	0.20	80
289	0.43	188
350	0.67	315
396	0.90	447
416	1.00	515



Note: Watts is for the entire unit.  
Note: Airflow performance includes effect of clean, standard filter supplied with unit.

Ship Schedules:
△ Contact Support Services

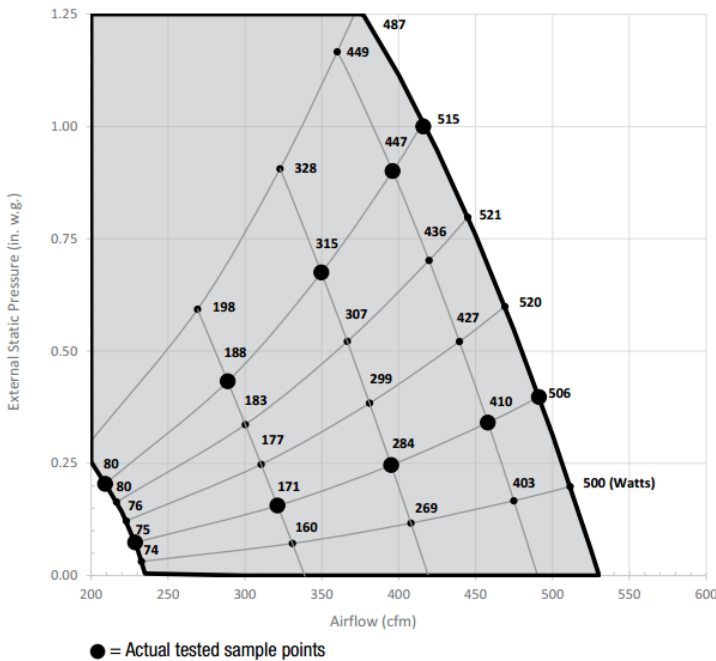

## CORE PERFORMANCE

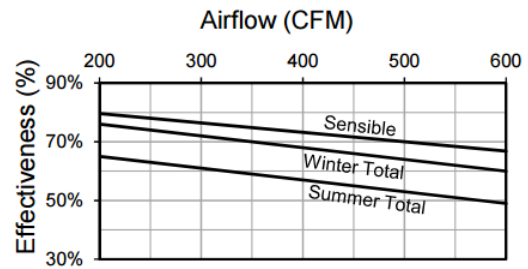

At AHRI 1060 standard conditions. See all AHRI certified ratings at [www.ahrinet.org](http://www.ahrinet.org).

Please refer to the General Catalog or contact the Factory for our Full Line of products available on standard shipping schedules.

# Model TRCe500

## Dimensions

EA: Exhaust Air to outdoors  
 OA: Outdoor Air intake  
 RA: Room Air to be exhausted  
 FA: Fresh Air to inside

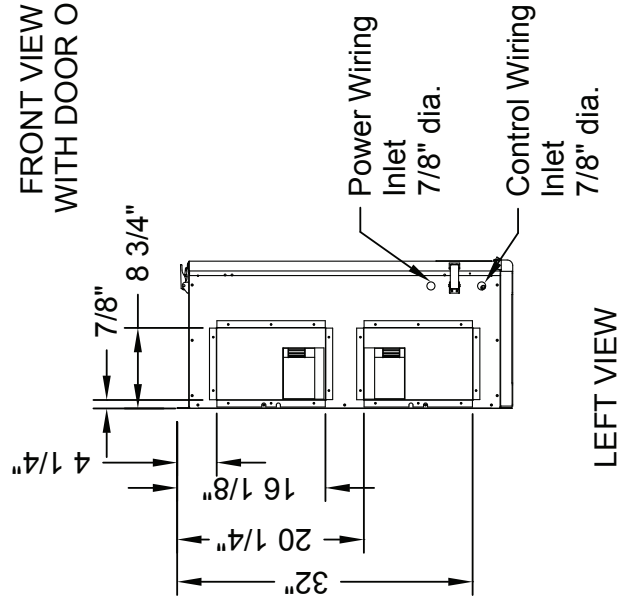
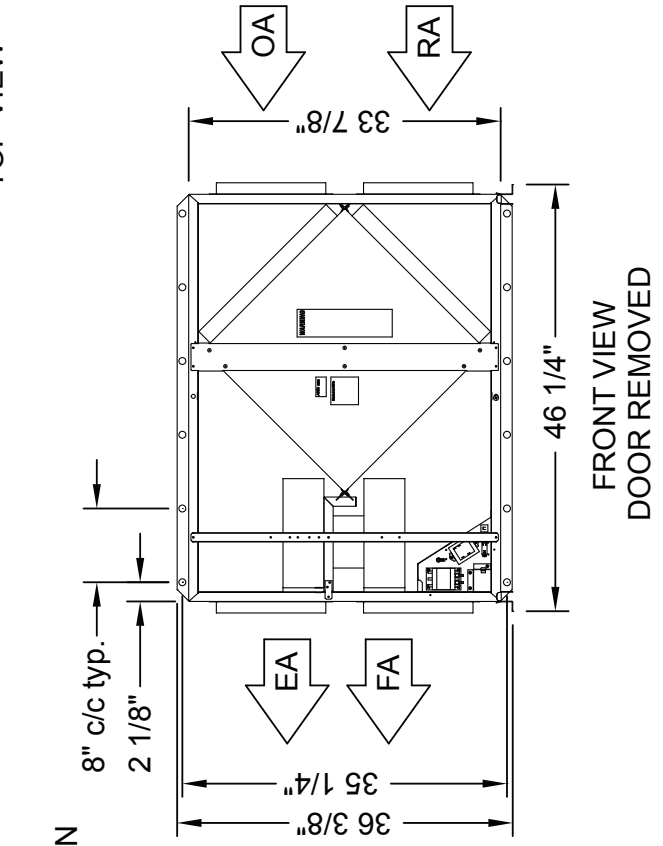
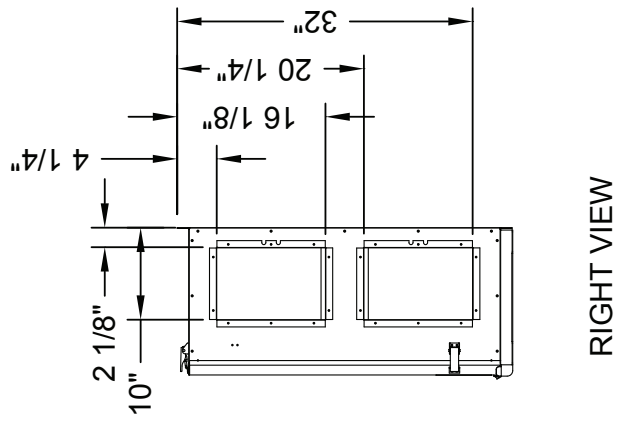
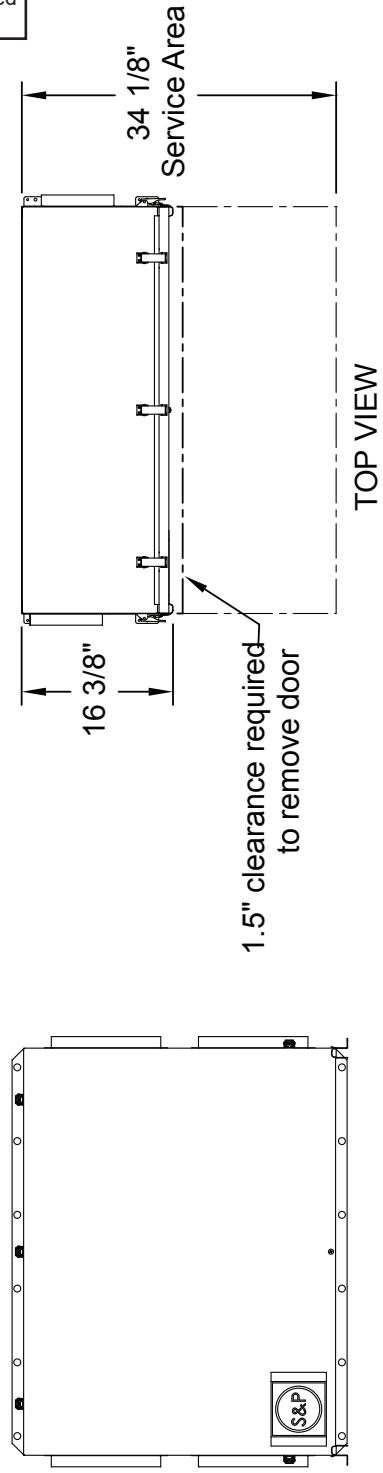

Please refer to the General Catalog or contact the Factory for our Full Line of products available on standard shipping schedules.

# Model TRCe800 - Horizontal Configuration



## Specifications

Ventilation Type: Static Plate, Heat and Humidity Transfer					
Typical Airflow Range: 250-1,000 CFM					
AHRI 1060 Certified Core: One L125-G5					
Airflow Rating Points (for AHRI): 750 CFM and 563 CFM					
Motors: Two, 0.5 HP, Direct Drive EC blower/motor package					
V	Hz	Phase	FLA (per motor)	Min. Cir. Amps	Max. Overcurrent Protection Device
120	60	Single	8.1	18.2	25
208-230	60	Single	4.8	10.8	15
Standard Features: Non-Fused Disconnect 24 VAC Transformer/Relay Package					
Filters: Two total, MERV 8, 2" pleated, 20" x 20" nominal size					
Weight: 211 lbs (unit), 325 lbs (shipping weight, on pallet)					
Shipping Dimensions: 63" L x 30" W x 56" H					

## Core Performance

Airflow CFM	ESP in H <sub>2</sub> O	Watts
324	0.04	86
446	0.07	150
647	0.15	300
794	0.24	564
929	0.33	827
1019	0.41	1042
300	0.11	91
406	0.20	160
579	0.42	359
713	0.65	599
828	0.89	871
883	1.00	1075

Ship Schedules:
△ Contact Support Services

Note: Watts is for the entire unit.  
Note: Airflow performance includes effect of clean, standard filter supplied with unit.

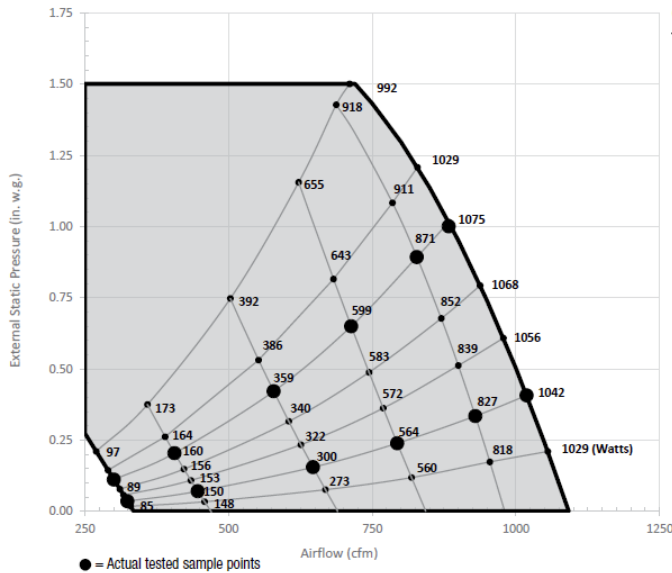

## CORE PERFORMANCE

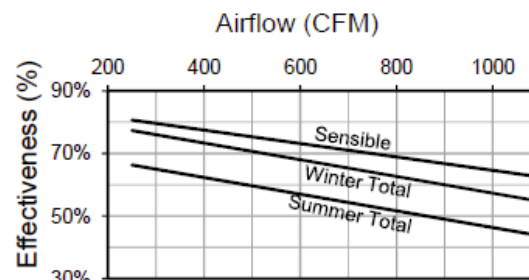

At AHRI 1060 standard conditions. See all AHRI certified ratings at [www.ahrinet.org](http://www.ahrinet.org).

Please refer to the General Catalog or contact the Factory for our Full Line of products available on standard shipping schedules.

# Model TRCe800 - Horizontal Configuration

## Dimensions

EA: Exhaust Air to outdoors  
 OA: Outdoor Air intake  
 RA: Room Air to be exhausted  
 FA: Fresh Air to inside

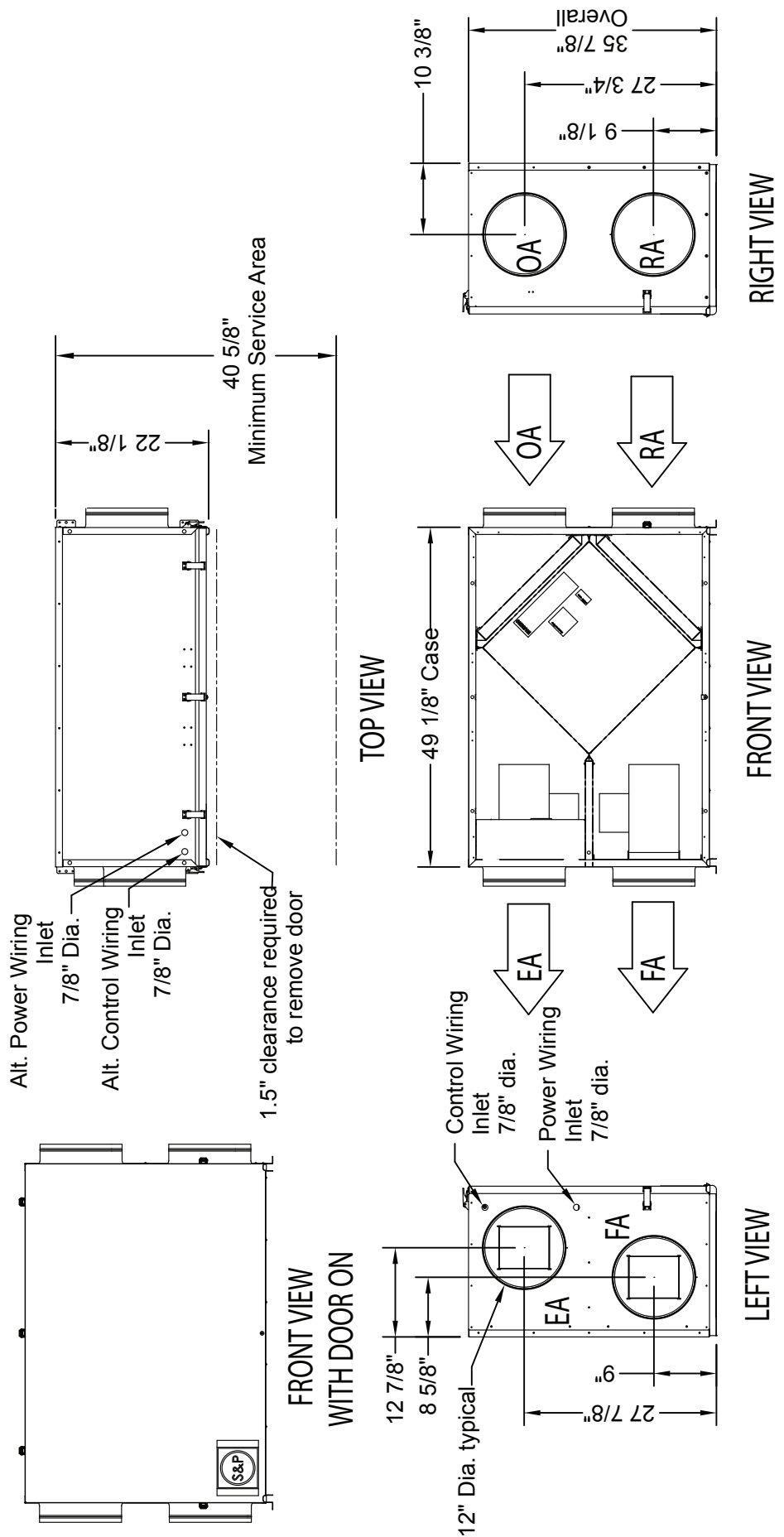

Please refer to the General Catalog or contact the Factory for our Full Line of products available on standard shipping schedules.

# Model TRCe800V - Vertical Configuration



## Specifications

Ventilation Type: Static Plate, Heat and Humidity Transfer					
Typical Airflow Range: 250-1,000 CFM					
AHRI 1060 Certified Core: One L125-G5					
Airflow Rating Points (for AHRI): 750 CFM and 563 CFM					
Motors: Two, 0.5 HP, Direct Drive EC blower/motor package					
V	Hz	Phase	FLA (per motor)	Min. Cir. Amps	Max. Overcurrent Protection Device
120	60	Single	8.1	18.2	25
208-230	60	Single	4.8	10.8	15
Standard Features: Non-Fused Disconnect 24 VAC Transformer/Relay Package					
Filters: Two total, MERV 8, 2" pleated, 20" x 20" nominal size					
Weight: 211 lbs (unit), 325 lbs (shipping weight, on pallet)					
Shipping Dimensions: 63" L x 30" W x 56" H					

## Core Performance

Airflow CFM	ESP in H <sub>2</sub> O	Watts
324	0.04	86
446	0.07	150
647	0.15	300
794	0.24	564
929	0.33	827
1019	0.41	1042
300	0.11	91
406	0.20	160
579	0.42	359
713	0.65	599
828	0.89	871
883	1.00	1075

Ship Schedules:
△ Contact Support Services

Note: Watts is for the entire unit.  
Note: Airflow performance includes effect of clean, standard filter supplied with unit.

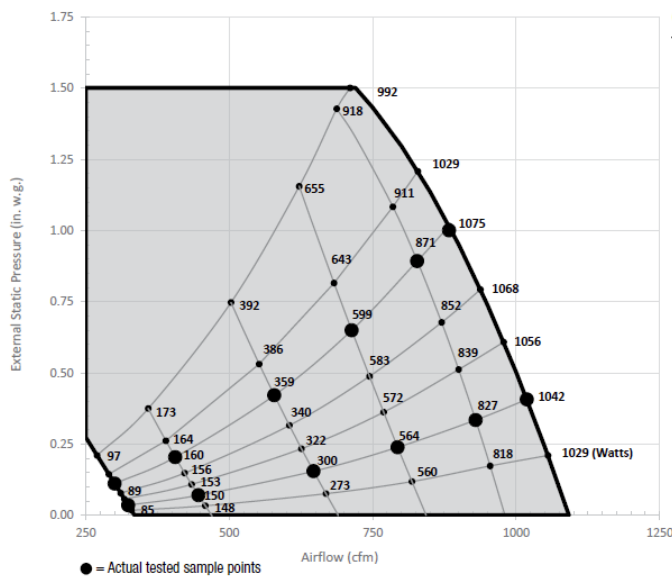

## CORE PERFORMANCE

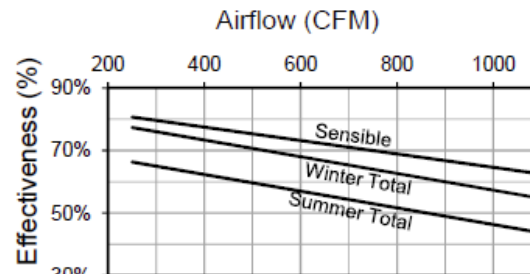

At AHRI 1060 standard conditions. See all AHRI certified ratings at [www.ahrinet.org](http://www.ahrinet.org).

Please refer to the General Catalog or contact the Factory for our Full Line of products available on standard shipping schedules.

# Model TRCe800V - Vertical Configuration Dimensions

EA: Exhaust Air to outdoors  
 OA: Outdoor Air intake  
 RA: Room Air to be exhausted  
 FA: Fresh Air to inside

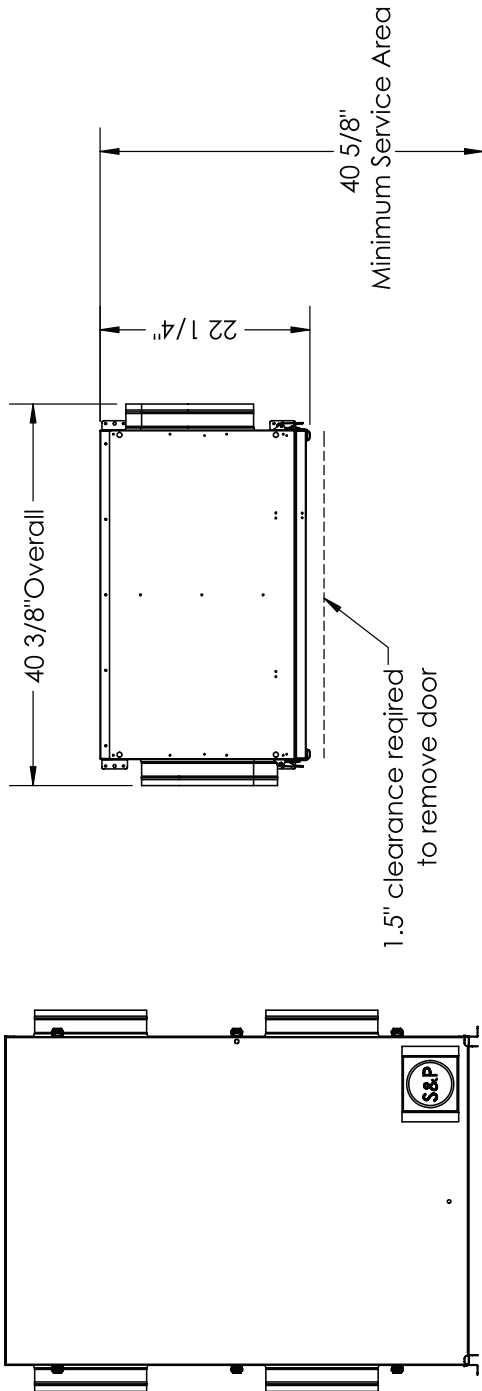

**FRONT VIEW WITH DOOR ON**

**TOP VIEW**

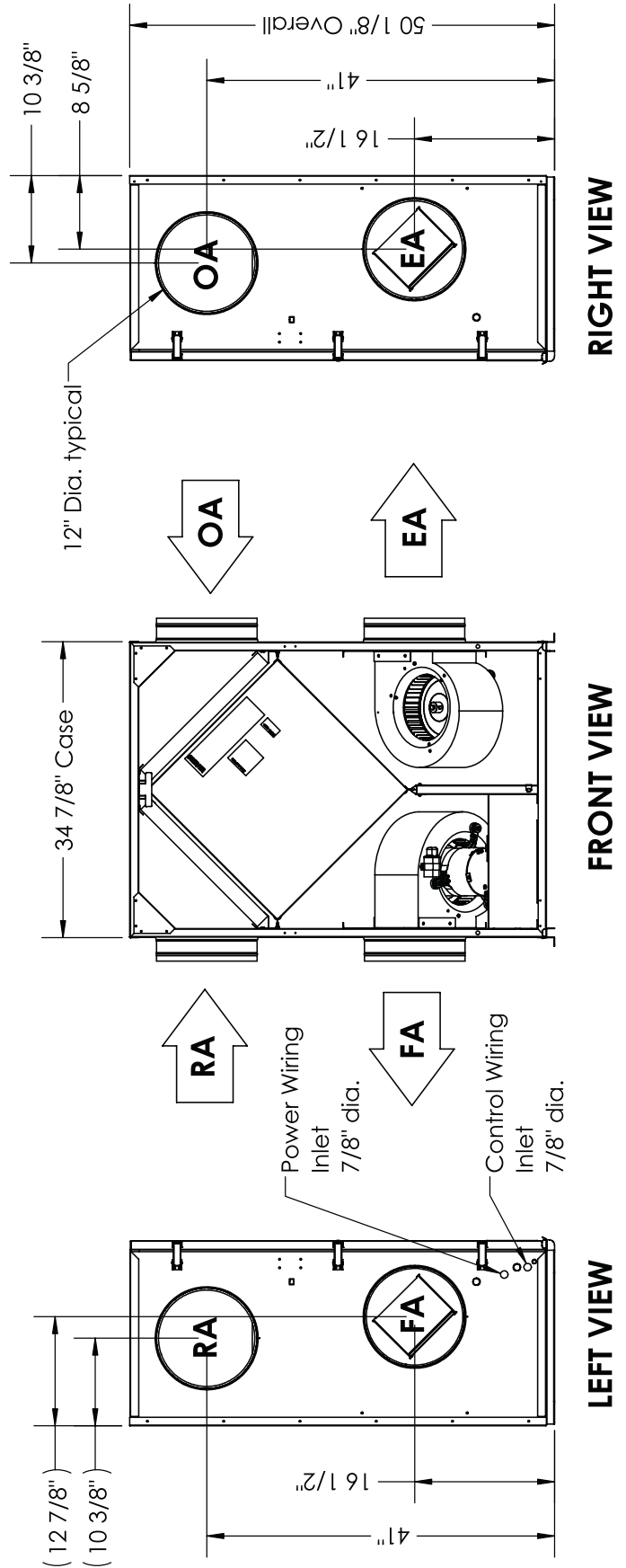

**RIGHT VIEW**

**FRONT VIEW**

**LEFT VIEW**



# Model TRCe1200

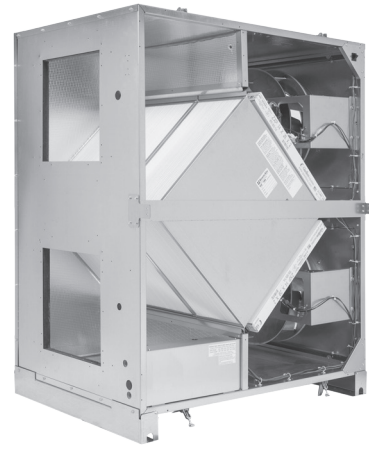

## Specifications

Ventilation Type: Static Plate, Heat and Humidity Transfer						
Typical Airflow Range: 375-1,575 CFM						
AHRI 1060 Certified Cores: One L62-G5 and one L125-G5						
Motors: Qty 2, 1.0 HP ea., Direct Drive EC blower/motor package						
Drive HP	V	Hz	Phase	FLA (per motor)	Min. Cir. Amps	Max. Overcurrent Protection Device
1.0	120	60	Single	6.5	14.6	20
	208-230	60	Single	3.3-3.4	7.7	15
Standard Features: Non-Fused Disconnect 24 VAC Transformer/Relay Package						
Filters: Total Qty. 4, MERV 8: (2) 14" x 20" x 2" and (2) 16" x 20" x 2"						
Dimensions & Weight: 53 1/4" L x 34 1/2" W x 53 3/4" H, 336-463 lbs. (varies)						
Shipping Dimensions & Weight (max. on pallet): 70" L x 47" W x 53" H, 530 lbs.						

Ship Schedules:  
 Contact Support Services

## CORE PERFORMANCE

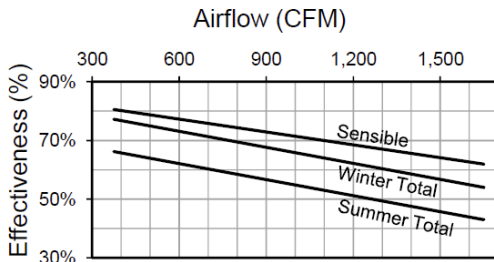

At AHRI 1060 standard conditions. See all AHRI certified ratings at [www.ahrinet.org](http://www.ahrinet.org).

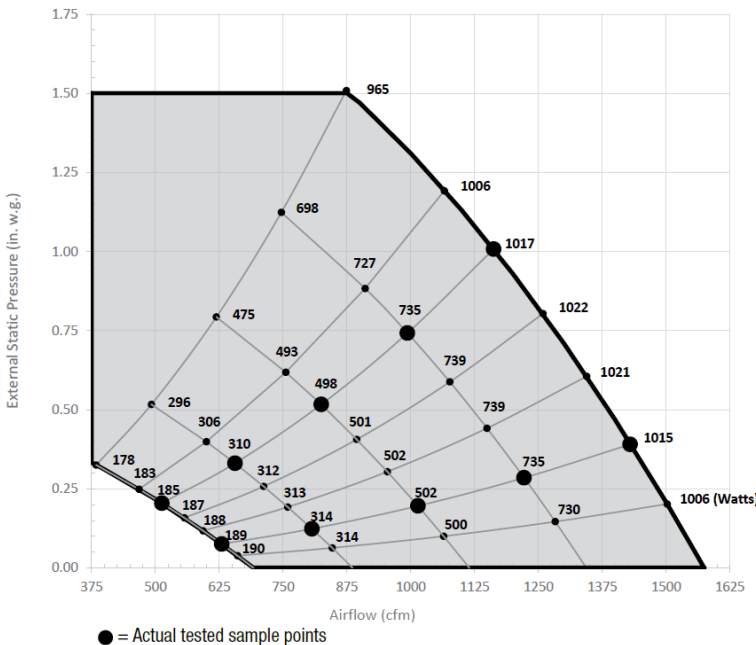

## Core Performance

Airflow CFM	ESP in H <sub>2</sub> O	Watts
630	0.07	189
807	0.12	314
1014	0.20	502
1222	0.28	735
1430	0.39	1015
513	0.20	185
656	0.33	310
825	0.52	498
994	0.74	735
1163	1.01	1017

Note: Watts is for the entire unit.  
 Note: Airflow performance includes effect of clean, standard filter supplied with unit.

Please refer to the General Catalog or contact the Factory for our Full Line of products available on standard shipping schedules.

# Model TRCe1200

## Dimensions

EA: Exhaust Air to outdoors  
 OA: Outdoor Air intake  
 RA: Room Air to be exhausted  
 FA: Fresh Air to inside

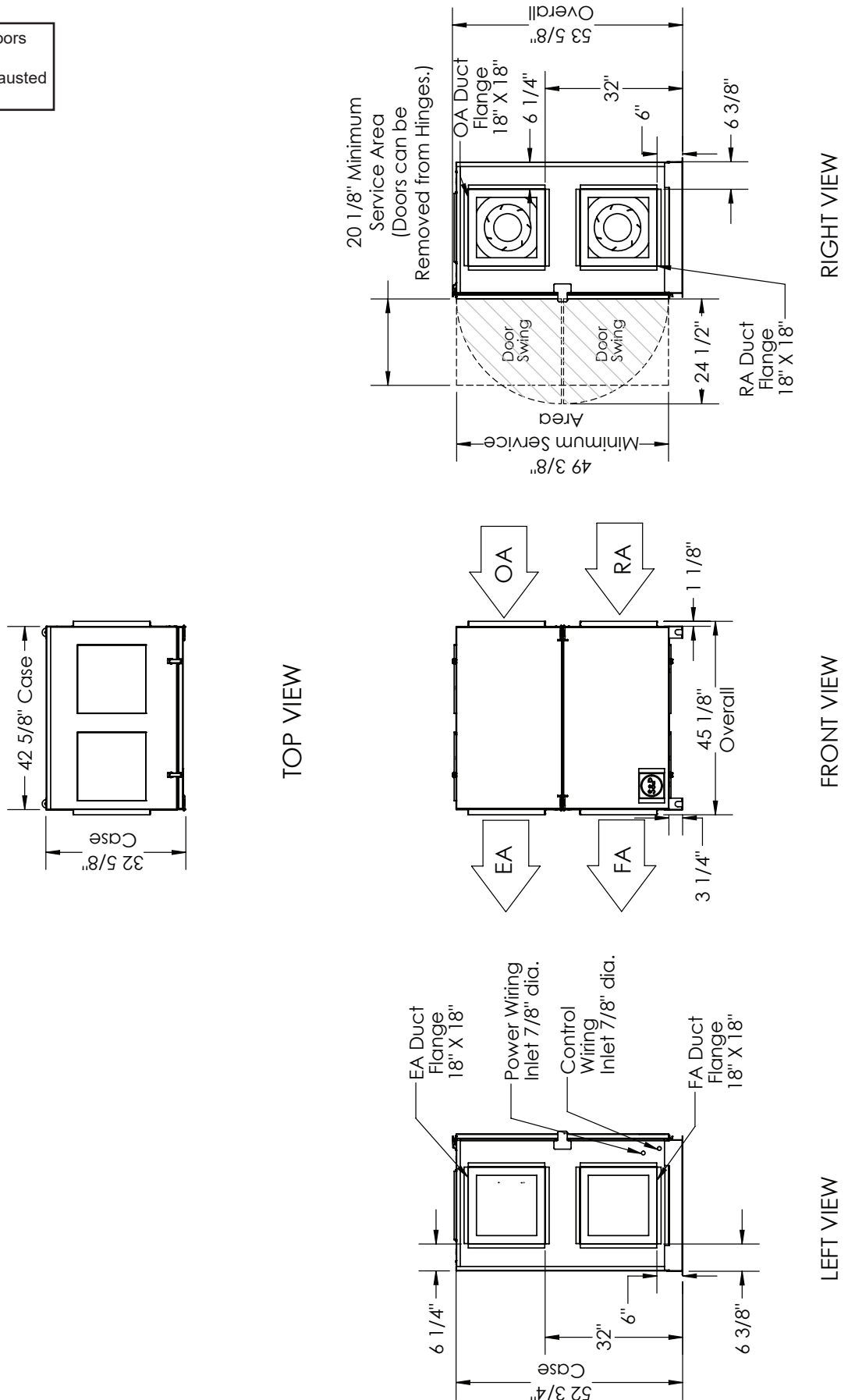

Please refer to the General Catalog or contact the Factory for our Full Line of products available on standard shipping schedules.

# MODEL ARE/ARS

## DOME AXIAL POWER ROOF EXHAUST/SUPPLY FAN

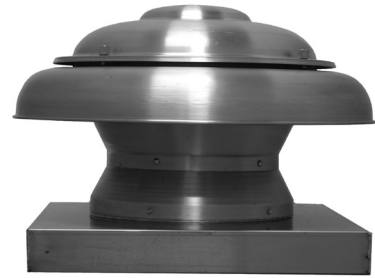

### APPLICATION

The ARE/ARS series offers powerful axial exhaust or supply performance in a roof mount design that is compact, lightweight and easy to install.

The ARE/ARS series is an excellent choice for factories, shops, restaurants, bathrooms, offices, schools and other similar applications where light to moderate static pressures are present.

The low contour designs and all aluminum housing provides a modern, clean appearance in addition to excellent performance and durability. The direct drive design has no belts or fan bearings to maintain or adjust and consequently requires very little maintenance.

### CONSTRUCTION

#### Housing

- Heavy-gauge all aluminum housing.
- Exclusive U-Spring suspension compensates for both radial and lateral movement and provides 44% better vibration isolation than rubber isolators.
- External wiring chase for easy connection.
- Quick access to motor compartment for easy maintenance.

#### Propeller

- Attaches directly to motor shaft for maximum efficiency.
- Precision pitched, heavy-gauge aluminum blades with steel hub. Blades are designed for specific exhaust or supply requirements.

#### Speed Controllable Motor

- Standard motors are single speed, speed controllable and drip-proof.
- All motors are rated for continuous duty.
- Disconnect is standard on ODP motors.
- Motors are shipped assembled with factory test run assurance.

### DIMENSIONAL DATA

MODEL ARE/ARS	A	B	C	D	E	F	Average Ship Wt. Lbs.
10	21	13	7	2	20	12 3/4	25
12	28	16	8	3	24	15 3/4	42
16	32	18	8 1/2	3	28	19 3/4	55
20	36	20	9 3/4	3	32	23 3/4	75



S&P USA Ventilation Systems, LLC., Div. of Soler & Palau Ventilation Group, certifies that the Models ARE & ARS shown herein are licensed to bear the AMCA Seal. The ratings shown are based on test and procedures performed in accordance with AMCA Publication 211 and AMCA Publication 311 and comply with the requirement of the AMCA Certified Ratings Program.



LISTED POWER ROOF VENTILATOR  
UL STANDARD 705

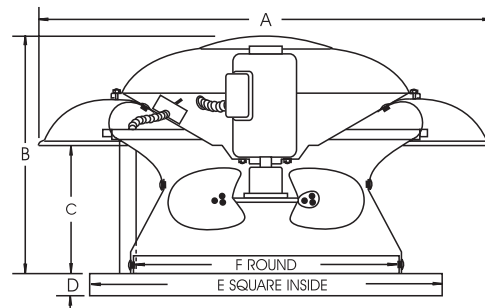

Ship Schedules:
● Next Day Shipment From Stock
▲ 3 Day Shipment From Stock
◆ 10 Day Shipment

### ACCESSORIES

MODEL ARE/ARS	RECOMMENDED 12" MOUNTING CURB		DAMPER ARE/ARS		DAMPER MOTOR ARE/ARS(LOOSE)	115 VOLT SPEED CONTROL	230 VOLT SPEED CONTROL
	OD	STOCK NO.	OD	STOCK NO.	STOCK NO.	STOCK NO.	STOCK NO.
10	18 1/2	711218 ●	14	411014 / S3GA12CB ●	411611 / MP2781 ●	2727.1 ●	3232.1 ◆
12	22 1/2	611222 ●	18	411018 / S3GA16CB ●	411611 / MP2781 ●	2727.1 ●	3232.1 ◆
16	26 1/2	92612221 ●	22	411022 / S3GA20CB ●	411611 / MP2781 ●	2727.1 ●	3232.1 ◆
20	30 1/2	93012221 ◆	26	411026 / S3GA24CB ◆	411611 / MP2781 ◆	2727.1 ◆	3232.1 ◆

### SPEED CONTROL 2727.1 MAX 1/3 HP-5 AMP 120V

ALL DIMENSIONS IN INCHES, WEIGHTS IN POUNDS. OD IS OUTSIDE DIMENSION OF SQUARE CURB AND DAMPER. DUE TO CONTINUING RESEARCH, S&P RESERVES THE RIGHT TO CHANGE SPECIFICATIONS WITHOUT NOTICE.

Please refer to the General Catalog or contact the Factory for our Full Line of products available on standard shipping schedules.

<b>MODEL ARE</b>					<b>Dome Direct Drive Propeller Exhaust Roof Fan</b>								<b>Ventilator with Open Drip-proof Motor</b>	
MODEL ARE	MOTOR Hp	MAX BHp	RPM	SONES @ 0 SP	CFM at Static Pressure								115/1/60	208-230/1/60
					0	1/10	1/8	1/4	3/8	1/2	5/8	3/4	STOCK NO.	STOCK NO.
10	1/15	0.15	1190	1.6	439	290	258	167	-	-	-	-	ARE10IH1AS ●	N/A
			1445	3.0	533	429	381	264	198	-	-	-		
			1700	5.0	627	540	520	373	297	242	178	-		
12	1/4	0.25	815	2.1	857	591	483	-	-	-	-	-	ARE12MM1AS ◆	ARE12MM1CS ◆
			990	4.1	1041	876	808	452	241	-	-	-		
			1160	5.9	1220	1082	1046	696	484	303	-	-		
	1/4	0.25	1185	4.6	1261	1135	1103	780	521	-	-	-	ARE12MH1AS ●	ARE12MH1CS ◆
			1440	7.6	1533	1426	1402	1247	934	703	543	-		
			1695	11.2	1804	1710	1689	1583	1416	1154	912	763		
16	1/4	0.25	800	2.8	1245	953	817	455	-	-	-	-	ARE16MM1AS ◆	ARE16MM1CS ◆
			975	5.4	1517	1290	1230	802	548	-	-	-		
			1145	7.5	1782	1590	1542	1189	882	671	-	-		
	1/3	0.33	1160	5.3	1827	1640	1589	1237	905	685	-	-	ARE16PH1AS ●	ARE16PH1CS ◆
			1410	8.4	2220	2069	2030	1820	1487	1191	994	816		
20	1/4	0.25	725	5.8	1990	1651	1555	986	584	-	-	-	ARE20MM1AS ◆	ARE20MM1CS ◆
			880	9.8	2415	2142	2070	1617	1177	845	-	-		
			1030	13.4	2827	2587	2532	2218	1768	1412	1122	844		

Performance certified is for installation type A – free inlet, free outlet.

The sound ratings shown are loudness values in fan sones @ 5' (1.5m) in a hemispherical free field calculated per AMCA Standard 301. Values shown are for: installation Type A: free inlet hemispherical sone levels.

Use 5 AMP Speed Control for motors 1/3 HP and smaller.

<b>MODEL ARS</b>					<b>Dome Direct Drive Propeller Supply Roof Fan</b>								<b>Ventilator with Open Drip-proof Motor</b>	
MODEL ARS	MOTOR Hp	MAX BHp	RPM	SONES @ 0 SP	CFM at Static Pressure								115/1/60	208-230/1/60
					0	1/10	1/8	1/4	3/8	1/2	5/8	3/4	STOCK NO.	STOCK NO.
10	1/15	0.15	1175	4.8	446	286	243	-	-	-	-	-	ARS10IH1AS ◆	N/A
			1425	6.1	541	415	376	209	-	-	-	-		
			1675	7.7	636	536	506	357	208	-	-	-		
12	1/4	0.25	820	4.5	683	383	317	-	-	-	-	-	ARS12MM1AS ◆	ARS12MM1CS ◆
			995	5.8	828	602	507	163	-	-	-	-		
			1170	8.0	974	808	749	462	-	-	-	-		
	1/4	0.25	1200	7.1	1011	862	814	506	-	-	-	-	ARS12MH1AS ◆	ARS12MH1CS ◆
			1450	11.8	1222	1100	1068	817	594	323	-	-		
			1715	16.4	1445	1347	1319	1173	907	738	561	206		
16	1/4	0.25	785	7.8	1229	945	858	442	-	-	-	-	ARS16MM1AS ◆	ARS16MM1CS ◆
			950	9.8	1488	1287	1230	853	494	-	-	-		
			1120	13.7	1754	1585	1540	1238	961	661	-	-		
	1/3	0.33	1090	9.2	1411	1151	1079	751	303	-	-	-	ARS16PH1AS ◆	ARS16PH1CS ◆
			1390	15.5	1799	1654	1583	1280	1019	749	304	-		
20	1/4	0.25	750	7.9	1850	1400	1273	-	-	-	-	-	ARS20MM1AS ◆	ARS20MM1CS ◆
			910	13.3	2245	1888	1789	1254	-	-	-	-		
			1065	18.2	2627	2342	2253	1815	1325	-	-	-		

Performance certified is for installation type A – free inlet, free outlet.

The sound ratings shown are loudness values in fan sones @ 5' (1.5m) in a hemispherical free field calculated per AMCA Standard 301. Values shown are for: installation Type A: free inlet hemispherical sone levels.

Use 5 AMP Speed Control for motors 1/3 HP and smaller.

Ship Schedules:
● Next Day Shipment From Stock
▲ 3 Day Shipment From Stock
◆ 10 Day Shipment

Please refer to the General Catalog or contact the Factory for our Full Line of products available on standard shipping schedules.

# MODEL GED

## SIDEWALL DIRECT DRIVE PROPELLER EXHAUST FAN

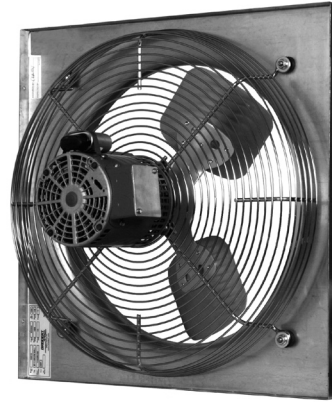

### APPLICATION

GED wall propeller fans feature the maximum efficiency, low maintenance and durable, economical operation resulting from the direct drive design. It is available in exhaust configurations to provide general ventilation for a wide variety of buildings and enclosed areas within buildings. Examples include factories, assembly plants, churches, gymnasiums, garages, jails, machine rooms and many others.

They feature extremely quiet operation and an integral motor side guard as standard.

### CONSTRUCTION

#### Panel Assembly

- 16 gauge galvanized steel.
- One piece spun venturi for maximum efficiency.
- Prepunched mounting holes for easy installation.
- Formed flanges for added rigidity.
- Integral OSHA approved motor side guard.

#### Propeller

- Attached directly to motor shaft for maximum efficiency.
- Precision pitched, fabricated aluminum blades (3 & 4 blade models).
- Polypropylene blades (6 blade models).
- Statically and dynamically balanced.

#### Motors

- Permanently lubricated sealed ball bearing type.
- Sleeve bearings on low HP models.
- Open drip-proof construction is standard.

#### Entire Fan Unit

- Suitable for all angle installation.
- Completely assembled and factory tested prior to shipment.



UL STANDARD 705



S&P USA Ventilation Systems, LLC., Div. of Soler & Palau Ventilation Group, certifies that the Models GED shown herein are licensed to bear the AMCA Seal. The ratings shown are based on test and procedures performed in accordance with AMCA Publication 211 and AMCA Publication 311 and comply with the requirement of the AMCA Certified Ratings Program.

### DIMENSIONAL DATA

MODEL GED	DIMENSIONS (IN.)						Average Ship Wt. Lbs.
	A	B	C	D	E*	F*	
10	16	10-1/2	1	2	11	9	30
12	16	12-1/2	1	2	14	12	30
14	20	14-1/2	1	2	14	12	34
16	20	16-1/2	1	2	14	12	37
18	24	18-1/2	1	2	15	13	45
20	24	20-1/2	1	2	15	13	50

- A. Outside dimension of square panel. D. Depth of venturi, 2" for all models.  
 B. Diameter of venturi. E. Depth of fan (exhaust).  
 C. Width of flange, 1" for all models. F. Depth of fan (supply).

\*Varies with motor selection.

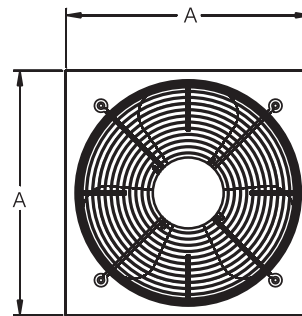

REAR VIEW

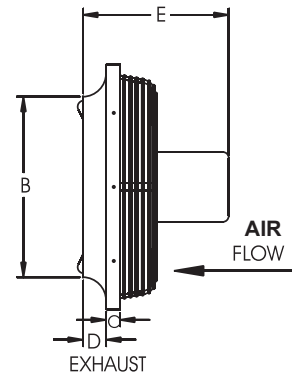

EXHAUST

### ACCESSORIES

MODEL GED	GRAVITY DAMPER	DAMPER MOTOR (LOOSE)	115 VOLT SPEED CONTROL	
	STOCK NO.	STOCK NO.	5 AMP STOCK NO.	10 AMP STOCK NO.
10	EAS12 ●	EAS1232MTR ●	2727.1 ●	N/A
12	EAS12 ●	EAS1232MTR ●	2727.1 ●	N/A
14	EAS16 ●	EAS1232MTR ●	2727.1 ●	2828.1 ●
16	EAS16 ●	EAS1232MTR ●	2727.1 ●	N/A
18	EAS20 ●	EAS1232MTR ●	2727.1 ●	2828.1 ●
20	EAS20 ●	EAS1232MTR ●	2727.1 ●	2828.1 ●

Ship Schedules:

- Next Day Shipment From Stock

**SPEED CONTROL 2727.1 MAX 1/3 HP-5 AMP 120V**  
**2828.1 MAX 1/2 HP-10 AMP 120V**

ALL DIMENSIONS IN INCHES, WEIGHTS IN POUNDS. OD IS OUTSIDE DIMENSION OF SQUARE SHUTTER DUE TO CONTINUING RESEARCH, S&P RESERVES THE RIGHT TO CHANGE SPECIFICATIONS WITHOUT NOTICE.

*Please refer to the General Catalog or contact the Factory for our Full Line of products available on standard shipping schedules.*

<b>MODEL GED</b>		<b>Sidewall Direct Drive Propeller Exhaust Fan</b>											Ventilator with Open Drip-proof Motor	
MODEL GED	MOTOR Hp	RPM	NO. OF BLADES	SONES @ 0° SP	CFM/Bhp at Static Pressure								115/1/60	
					0	1/10	1/8	1/4	3/8	1/2	5/8	3/4	STOCK NO.	
10	1/10	1550	4	6.5	847/0.1	708/0.1	673/0.1	480/0.1	-	-	-	-	-	GED10JH1AS ●
12	1/10	1550	4	9.8	1448/0.1	1331/0.1	1300/0.1	883/0.1	-	-	-	-	-	GED12JH1AS ●
	1/4	1625	4	10.5	1605/0.17	1521/0.17	1490/0.17	1357/0.19	918/0.19	591/0.22	-	-	-	GED12MH1AS ●
14	1/4	1625	4	9.4	2150/0.25	2045/0.26	2000/0.26	1825/0.26	1500/0.26	1125/0.26	850/0.26	-	-	GED14MH1AS ●
	1/2	1625	4	12.4	2675/0.53	2518/0.53	2460/0.53	2180/0.53	1760/0.53	1550/0.53	1275/0.53	-	-	GED14QH1AS ●
16	1/4	1075	4	9.7	2570/0.26	2350/0.26	2275/0.26	1508/0.26	515/0.26	-	-	-	-	GED16MM1AS ●
	1/3	1625	3	13.1	2805/0.34	2675/0.34	2625/0.34	2470/0.34	2215/0.34	1615/0.34	1150/0.34	765/0.34	-	GED16PH1AS ●
18	1/4	1075	3	9.1	3060/0.25	2790/0.26	2725/0.25	2140/0.25	1060/0.25	-	-	-	-	GED18MM1AS ●
	1/4	1625	3	16.3	3050/0.25	2875/0.26	2815/0.26	2600/0.26	2310/0.26	1765/0.26	1115/0.26	715/0.26	-	GED18MH1AS ●
	1/2	1625	3	16.5	3975/0.53	3815/0.53	3760/0.53	3560/0.53	3235/0.53	2920/0.53	1870/0.53	1450/0.53	-	GED18QH1AS ●
20	1/4	1075	3	10.7	3510/0.26	3200/0.26	3150/0.26	2615/0.26	1300/0.26	545/0.26	-	-	-	GED20MM1AS ●
	1/2	1625	3	16.1	3625/0.53	3425/0.53	3375/0.53	3125/0.53	2750/0.53	2275/0.53	1800/0.53	1425/0.53	-	GED20QH1AS ●

Speed (RPM) shown is nominal. Performance is based on actual speed of test.

Performance ratings include the effects of appurtenances (accessories).

Performance certified is for installation type A-free inlet, free outlet.

The sound ratings shown are loudness values in fan sones @ 5' (1.5m) in a hemispherical free field calculated per AMCA Standard 301.

Installation Type A: free inlet hemispherical sone levels.

Fans use 3 & 4 blade fabricated aluminum propellers.

Ship Schedules:
● Next Day Shipment From Stock
▲ 3 Day Shipment From Stock
◆ 10 Day Shipment

**ASSEMBLED WALL HOUSING PACK - EXHAUST**  
**ASSEMBLED FAN/WALL HOUSING/DAMPER/OSHA GUARD**

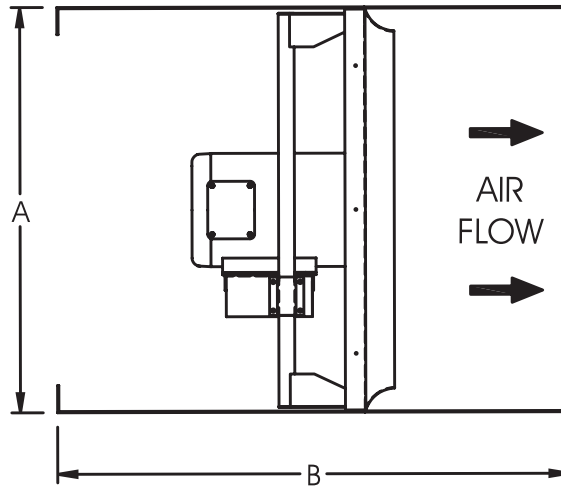

MODEL GED	A	B	PACK WITH GRAVITY DAMPER	PACK WITH MOTORIZED DAMPER
			STOCK NO.	STOCK NO.
10	17	26	WHPGED1012 ●	WHPGED1012M ●
12	17	26	WHPGED1012 ●	WHPGED1012M ●
14	21	26	WHPGED1416 ●	WHPGED1416M ●
16	21	26	WHPGED1416 ●	WHPGED1416M ●
18	25	26	WHPGED1820 ●	WHPGED1820M ●
20	25	26	WHPGED1820 ●	WHPGED1820M ●

Please refer to the General Catalog or contact the Factory for our Full Line of products available on standard shipping schedules.



# MODEL LCE

## SIDEWALL BELT DRIVE PROPELLER EXHAUST FAN

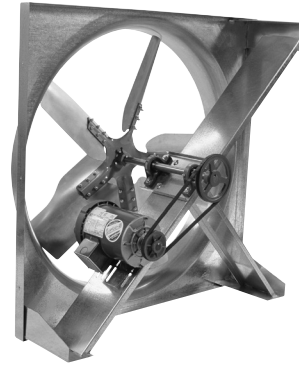

### APPLICATION

Model LCE (exhaust) are high capacity belt driven propeller fans. Their primary application is the exhaust of large volumes of air at relatively low static pressures from commercial, light industrial and agricultural buildings such as manufacturing and assembly plants, warehouses, parking garages, gymnasiums, equipment rooms, distribution centers, poultry and greenhouses.

Belt driven fans provide large volumes of air at low fan speeds and low noise levels and afford quick, easy performance adjustments.

### CONSTRUCTION

#### Panel Assembly

- Heavy-gauge galvanized steel.
- All welded motor & drive support frame assembly.
- Prepunched mounting holes.

#### Propeller

- Die formed galvanized steel blades.
- Epoxy coated hub keyed to fan shaft.
- Statically and dynamically balanced.

#### Drives

- Sized for minimum 150% of drive horsepower.
- Single belt adjustable pitch sheaves through 3 HP.
- Nonstatic v-belts.

#### Bearings

- Designed for minimum 200,000 hour life.
- Bearings are sealed, prelubricated with relube fittings.

#### Motors

- Open drip-proof construction is standard.
- All motors mounted and factory run tested.



S&P USA Ventilation Systems, LLC., Div. of Soler & Palau Ventilation Group, certifies that the Models LC shown herein are licensed to bear the AMCA Seal. The ratings shown are based on test and procedures performed in accordance with AMCA Publication 211 and AMCA Publication 311 and comply with the requirement of the AMCA Certified Ratings Program.



UL STANDARD 705

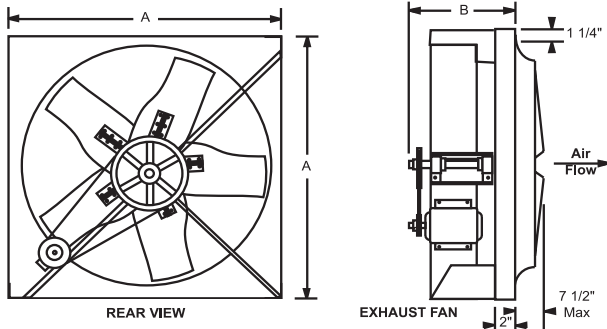

### DIMENSIONAL DATA

MODEL LCE	A	B	Avg. Ship Wt. Lbs
20	24	15	85
24	30	15	90
30	36	15	100
36	42	15	105
42	48	16	110
48	54	16	125
54	60	20	240
60	66	20	285

### ACCESSORIES

MODEL LCE	RECOMMENDED DAMPER*		DAMPER MOTOR (LOOSE)	WALL HOUSING PACK WITH GRAVITY DAMPER	WALL HOUSING PACK WITH MOTORIZED DAMPER	RAINHOOD	RAINHOOD BIRDSCREEN
	OD	STOCK NO.	STOCK NO.	STOCK NO.	STOCK NO.	STOCK NO.	STOCK NO.
20	22 1/2	EAS20 ●	EAS1232MTR ●	WHPLCE20 ●	WHPLCE20M ▲	5520.8.20KDS ●	5521.5.20RHS ●
24	28 1/2	EAS26 ●	EAS1232MTR ●	WHPLCE24 ●	WHPLCE24M ▲	5520.8.24KDS ●	5521.5.24RHS ●
30	34 1/2	EAS32 ●	EAS1232MTR ●	WHPLCE30 ●	WHPLCE30M ▲	5520.8.30KDS ●	5521.5.30RHS ●
36	40 1/2	EAS38 ●	EAS3850MTR ●	WHPLCE36 ●	WHPLCE36M ▲	5520.8.36KDS ●	5521.5.36RHS ●
42	46 1/2	EAS44 ●	EAS3850MTR ●	WHPLCE42 ●	WHPLCE42M ▲	5520.8.42KDS ●	5521.5.42RHS ●
48	52 1/2	EAS50 ●	EAS3850MTR ●	WHPLCE48 ●	WHPLCE48M ▲	5520.8.48KDS ●	5521.5.48RHS ●
54	58 1/2	S3GA54 ◆	MA220 ◆	WHPLCE54 ◆	WHPLCE54M ◆	5520.8.54KDS ◆	5521.5.54RHS ◆
60	64 1/2	S3GA62 ◆	MA220 ◆	WHPLCE60 ◆	WHPLCE60M ◆	5520.8.60KDS ◆	5521.5.60RHS ◆

Ship Schedules:
● Next Day Shipment From Stock
▲ 3 Day Shipment From Stock
◆ 10 Day Shipment

ALL DIMENSIONS IN INCHES, WEIGHTS IN POUNDS. OD IS OUTSIDE DIMENSION OF SQUARE SHUTTER DUE TO CONTINUING RESEARCH, S&P RESERVES THE RIGHT TO CHANGE SPECIFICATIONS WITHOUT NOTICE.

Please refer to the General Catalog or contact the Factory for our Full Line of products available on standard shipping schedules.

<b>MODEL LCE</b>					<b>Sidewall Belt Drive Propeller Exhaust Fan</b>						<b>Ventilator with Open Drip-proof Motor and Drive Assembly</b>	
Model LCE	Motor Hp	Max BHP	RPM	SONES @ 0 SP	CFM at Static Pressure						115/160*	208-230/460/3/60
					0	1/10	1/8	1/4	3/8	1/2	STOCK NO.	STOCK NO.
20	1/4	0.30	955	11.5	3983	3600	3491	-	-	-	LCE20MH1S ●	LCE20MH3S ●
	1/3	0.40	1050	13.5	4379	4038	3941	3312	-	-	LCE20PH1S ●	LCE20PH3S ●
	1/2	0.60	1180	16.4	4921	4625	4543	4081	3182	-	LCE20QH1S ●	LCE20QH3S ●
	3/4	0.90	1350	20.0	5630	5377	5308	4934	4462	3538	LCE20RH1S ●	LCE20RH3S ●
24	1/4	0.30	600	10.2	5331	4652	4431	2269	-	-	LCE24MH1S ●	LCE24MH3S ●
	1/3	0.41	660	12.1	5864	5268	5086	3702	-	-	LCE24PH1S ●	LCE24PH3S ●
	1/2	0.60	760	15.7	6753	6254	6112	5212	-	-	LCE24QH1S ●	LCE24QH3S ●
	3/4	0.90	875	19.8	7775	7352	7237	6562	5600	-	LCE24RH1S ●	LCE24RH3S ●
	1	1.20	950	22.0	8441	8057	7953	7369	6625	5559	LCE24SH1S ●	LCE24SH3S ●
	1 1/2	1.82	1100	28.0	9774	9447	9361	8894	8347	7688	LCE24TH1S ●	LCE24TH3S ●
30	1/4	0.30	450	9.0	7365	6062	5572	-	-	-	LCE30MH1S ●	LCE30MH3S ●
	1/3	0.40	495	10.5	8101	6954	6603	-	-	-	LCE30PH1S ●	LCE30PH3S ●
	1/2	0.59	565	13.3	9247	8271	7995	6052	-	-	LCE30QH1S ●	LCE30QH3S ●
	3/4	0.90	650	17.1	10638	9853	9594	8198	-	-	LCE30RH1S ●	LCE30RH3S ●
	1	1.20	715	20.0	11702	11021	10802	9659	8052	-	LCE30SH1S ●	LCE30SH3S ●
	1 1/2	1.78	815	24.0	13339	12773	12599	11609	10482	9013	LCE30TH1S ●	LCE30TH3S ●
36	1/3	0.41	390	9.7	10755	8745	7976	-	-	-	LCE36PH1S ●	LCE36PH3S ●
	1/2	0.59	440	11.9	12133	10449	9923	-	-	-	LCE36QH1S ●	LCE36QH3S ●
	3/4	0.90	505	15.3	13926	12485	12100	9348	-	-	LCE36RH1S ●	LCE36RH3S ●
	1	1.19	555	18.1	15305	14018	13663	11419	-	-	LCE36SH1S ●	LCE36SH3S ●
	1 1/2	1.79	635	22.0	17511	16413	16111	14497	12146	-	LCE36TH1S ●	LCE36TH3S ●
	2	2.37	695	25.0	19165	18176	17907	16499	14594	12363	LCE36VH1S ●	LCE36VH3S ●
42	1/3	0.41	305	8.4	13173	9658	8439	-	-	-	LCE42PH1S ●	LCE42PH3S ●
	1/2	0.60	345	9.8	14901	12109	11073	-	-	-	LCE42QH1S ●	LCE42QH3S ●
	3/4	0.90	395	12.6	17060	14724	14044	7292	-	-	LCE42RH1S ●	LCE42RH3S ●
	1	1.20	435	14.9	18788	16703	16128	12182	-	-	LCE42SH1S ●	LCE42SH3S ●
	1 1/2	1.81	500	18.8	21596	19833	19339	16470	11827	-	LCE42TH1S ●	LCE42TH3S ●
	2	2.40	550	22.0	23755	22182	21746	19393	16034	-	LCE42VH1S ●	LCE42VH3S ●
48	1/2	0.62	290	10.0	17979	13841	12199	-	-	-	LCE48QH1S ●	LCE48QH3S ●
	3/4	0.91	330	12.1	20459	16949	15969	-	-	-	LCE48RH1S ●	LCE48RH3S ●
	1	1.23	365	14.3	22629	19504	18659	10868	-	-	LCE48SH1S ●	LCE48SH3S ●
	1 1/2	1.82	415	17.8	25729	23054	22306	17746	-	-	LCE48TH1S ●	LCE48TH3S ●
	2	2.39	455	21.0	28209	25800	25148	21574	15382	-	LCE48VH1S ●	LCE48VH3S ●
54	3/4	0.92	270	11.0	23384	-	17932	-	-	-	LCE54RH1S ◆	LCE54RH3S ◆
	1	1.20	295	13.1	25550	-	20825	-	-	-	LCE54SH1S ◆	LCE54SH3S ◆
	1 1/2	1.84	340	16.8	29447	-	25449	19183	-	-	LCE54TH1S ◆	LCE54TH3S ◆
	2	2.38	370	19.4	32045	-	28375	23692	-	-	LCE54VH1S ◆	LCE54VH3S ◆
	3	3.60	425	24.0	36809	-	33585	30290	24785	15677	N/A	LCE54WH3S ◆
60	1	1.21	265	11.5	28491	-	22275	-	-	-	LCE60SH1S ◆	LCE60SH3S ◆
	1 1/2	1.75	300	14.3	32254	-	27023	-	-	-	LCE60TH1S ◆	LCE60TH3S ◆
	2	2.44	335	17.1	36017	-	31464	25399	-	-	LCE60VH1S ◆	LCE60VH3S ◆
	3	3.56	380	21.0	40855	-	36826	32244	29351	-	N/A	LCE60WH3S ◆

Performance ratings include the effects of appurtenances (accessories).

Power ratings (BHP) do not include transmission losses.

Performance certified is for installation type A-free inlet, free outlet.

The sound ratings shown are loudness values in fan sones @ 5' (1.5m) in a hemispherical free field calculated per AMCA Standard 301.

Installation Type A: free inlet hemispherical sone levels.

\*Tri-voltage (115-208-230) is standard on 3/4 through 1 1/2 Hp Single phase motors. Tri-voltage is available for the 1/2 Hp motors. Inquire for price and delivery.

Ship Schedules:
● Next Day Shipment From Stock
▲ 3 Day Shipment From Stock
◆ 10 Day Shipment

Please refer to the General Catalog or contact the Factory for our Full Line of products available on standard shipping schedules.

# MODEL LCS

## SIDEWALL BELT DRIVE PROPELLER SUPPLY FAN

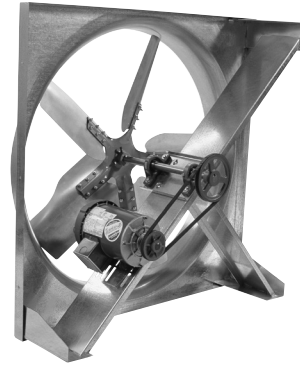

### APPLICATION

Model LCS (supply) are high capacity belt driven propeller fans. Their primary application is the supply of large volumes of air at relatively low static pressures from commercial, light industrial and agricultural buildings such as manufacturing and assembly plants, warehouses, parking garages, gymnasiums, equipment rooms, distribution centers, poultry and greenhouses.

Belt driven fans provide large volumes of air at low fan speeds and low noise levels and afford quick, easy performance adjustments.

When suspended from the ceiling, thus keeping floor spaces open, model LC can be installed to direct large volumes of air downward toward work centers improving employee comfort and productivity.

### CONSTRUCTION

#### Panel Assembly

- Heavy-gauge galvanized steel.
- All welded motor & drive support frame assembly.
- Prepunched mounting holes.

#### Propeller

- Die formed galvanized steel blades.
- Epoxy coated hub keyed to fan shaft.
- Statically and dynamically balanced.

### Drives

- Sized for minimum 150% of drive horsepower.
- Single belt adjustable pitch sheaves through 3 HP.
- Nonstatic v-belts.

### Bearings

- Designed for minimum 200,000 hour life.
- Bearings are sealed, prelubricated with relube fittings.

### Motors

- Open drip-proof construction is standard.
- All motors mounted and factory run tested.



S&P USA Ventilation Systems, LLC., Div. of Soler & Palau Ventilation Group, certifies that the Models LC shown herein are licensed to bear the AMCA Seal. The ratings shown are based on test and procedures performed in accordance with AMCA Publication 211 and AMCA Publication 311 and comply with the requirement of the AMCA Certified Ratings Program.



UL STANDARD 705

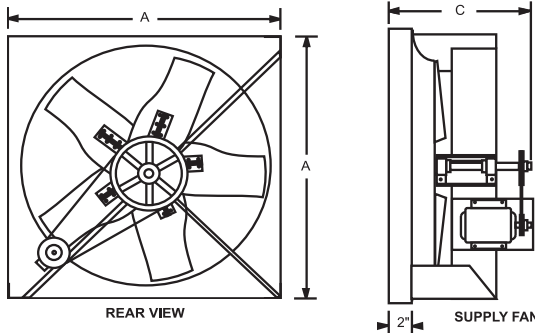

### DIMENSIONAL DATA

MODEL LCS	A	C	Avg. Ship Wt. Lbs
20	24	23	85
24	30	23	90
30	36	24	100
36	42	24	105
42	48	24	110
48	54	24	125
54	60	26	240
60	66	26	285

Ship Schedules:	
●	Next Day Shipment From Stock
▲	3 Day Shipment From Stock
◆	10 Day Shipment

### ACCESSORIES

MODEL LCS	RECOMMENDED DAMPER* (SUPPLY)		DAMPER MOTOR (LOOSE)	WALL HOUSING PACK WITH GRAVITY DAMPER (SUPPLY)*	WALL HOUSING PACK WITH MOTORIZED DAMPER (SUPPLY)*	RAINHOOD (SUPPLY)*	RAINHOOD BIRDSCREEN (SUPPLY)*
	OD	STOCK NO.	STOCK NO.	STOCK NO.	STOCK NO.	STOCK NO.	STOCK NO.
20	22 1/2	S3GA20RF ◆ ●	MP2781 ●	WHPLCS20 ●	WHPLCS20M ▲	7520.8.20KDS ●	7521.5.20RHS ●
24	28 1/2	S3GA26RF ◆ ●	MP2781 ●	WHPLCS24 ●	WHPLCS24M ▲	7520.8.24KDS ●	7521.5.24RHS ●
30	34 1/2	S3GA32RF ◆ ●	MP2781 ●	WHPLCS30 ●	WHPLCS30M ▲	7520.8.30KDS ●	7521.5.30RHS ●
36	40 1/2	S3GA38RF ●	MA220 ●	WHPLCS36 ●	WHPLCS36M ▲	7520.8.36KDS ●	7521.5.36RHS ●
42	46 1/2	S3GA44RF ●	MA220 ●	WHPLCS42 ●	WHPLCS42M ▲	7520.8.42KDS ●	7521.5.42RHS ●
48	52 1/2	S3GA50RF ●	MA220 ●	WHPLCS48 ●	WHPLCS48M ▲	7520.8.48KDS ●	7521.5.48RHS ●
54	58 1/2	S3GA56RF ◆	MA220 ◆	WHPLCS54 ◆	WHPLCS54M ◆	7520.8.54KDS ◆	7521.5.54RHS ◆
60	64 1/2	S3GA60RF ◆	MA220 ◆	WHPLCS60 ◆	WHPLCS60M ◆	7520.8.60KDS ◆	7521.5.60RHS ◆

ALL DIMENSIONS IN INCHES, WEIGHTS IN POUNDS. OD IS OUTSIDE DIMENSION OF SQUARE SHUTTER DUE TO CONTINUING RESEARCH, S&P RESERVES THE RIGHT TO CHANGE SPECIFICATIONS WITHOUT NOTICE.

Please refer to the General Catalog or contact the Factory for our Full Line of products available on standard shipping schedules.

<b>MODEL LCS</b>					<b>Sidewall Belt Drive Propeller Supply Fan</b>						<b>Ventilator with Open Drip-proof Motor and Drive Assembly</b>			
Model LCS	Motor Hp	Max BHp	RPM	SONES @ 0 SP	CFM at Static Pressure						115/1/60*	208-230/460/3/60		
					0	1/10	1/8	1/4	3/8	1/2	STOCK NO.	STOCK NO.		
20	1/4	0.30	955	11.5	3983	3600	3491	-	-	-	LCS20MH1S	●	LCS20MH3S	●
	1/3	0.40	1050	13.5	4379	4038	3941	3312	-	-	LCS20PH1S	●	LCS20PH3S	●
	1/2	0.60	1180	16.4	4921	4625	4543	4081	3182	-	LCS20QH1S	●	LCS20QH3S	●
	3/4	0.90	1350	20.0	5630	5377	5308	4934	4462	3538	LCS20RH1S	●	LCS20RH3S	●
24	1/4	0.30	600	10.2	5331	4652	4431	2269	-	-	LCS24MH1S	●	LCS24MH3S	●
	1/3	0.41	660	12.1	5864	5268	5086	3702	-	-	LCS24PH1S	●	LCS24PH3S	●
	1/2	0.60	760	15.7	6753	6254	6112	5212	-	-	LCS24QH1S	●	LCS24QH3S	●
	3/4	0.90	875	19.8	7775	7352	7237	6562	5600	-	LCS24RH1S	●	LCS24RH3S	●
	1	1.20	950	22.0	8441	8057	7953	7369	6625	5559	LCS24SH1S	●	LCS24SH3S	●
	1 1/2	1.82	1100	28.0	9774	9447	9361	8894	8347	7688	LCS24TH1S	●	LCS24TH3S	●
30	1/4	0.30	450	9.0	7365	6062	5572	-	-	-	LCS30MH1S	●	LCS30MH3S	●
	1/3	0.40	495	10.5	8101	6954	6603	-	-	-	LCS30PH1S	●	LCS30PH3S	●
	1/2	0.59	565	13.3	9247	8271	7995	6052	-	-	LCS30QH1S	●	LCS30QH3S	●
	3/4	0.90	650	17.1	10638	9853	9594	8198	-	-	LCS30RH1S	●	LCS30RH3S	●
	1	1.20	715	20.0	11702	11021	10802	9659	8052	-	LCS30SH1S	●	LCS30SH3S	●
	1 1/2	1.78	815	24.0	13339	12773	12599	11609	10482	9013	LCS30TH1S	●	LCS30TH3S	●
36	1/3	0.41	390	9.7	10755	8745	7976	-	-	-	LCS36PH1S	●	LCS36PH3S	●
	1/2	0.59	440	11.9	12133	10449	9923	-	-	-	LCS36QH1S	●	LCS36QH3S	●
	3/4	0.90	505	15.3	13926	12485	12100	9348	-	-	LCS36RH1S	●	LCS36RH3S	●
	1	1.19	555	18.1	15305	14018	13663	11419	-	-	LCS36SH1S	●	LCS36SH3S	●
	1 1/2	1.79	635	22.0	17511	16413	16111	14497	12146	-	LCS36TH1S	●	LCS36TH3S	●
	2	2.37	695	25.0	19165	18176	17907	16499	14594	12363	LCS36VH1S	●	LCS36VH3S	●
42	1/3	0.41	305	8.4	13173	9658	8439	-	-	-	LCS42PH1S	●	LCS42PH3S	●
	1/2	0.60	345	9.8	14901	12109	11073	-	-	-	LCS42QH1S	●	LCS42QH3S	●
	3/4	0.90	395	12.6	17060	14724	14044	7292	-	-	LCS42RH1S	●	LCS42RH3S	●
	1	1.20	435	14.9	18788	16703	16128	12182	-	-	LCS42SH1S	●	LCS42SH3S	●
	1 1/2	1.81	500	18.8	21596	19833	19339	16470	11827	-	LCS42TH1S	●	LCS42TH3S	●
	2	2.40	550	22.0	23755	22182	21746	19393	16034	-	LCS42VH1S	●	LCS42VH3S	●
48	1/2	0.62	290	10.0	17979	13841	12199	-	-	-	LCS48QH1S	●	LCS48QH3S	●
	3/4	0.91	330	12.1	20459	16949	15969	-	-	-	LCS48RH1S	●	LCS48RH3S	●
	1	1.23	365	14.3	22629	19504	18659	10868	-	-	LCS48SH1S	●	LCS48SH3S	●
	1 1/2	1.82	415	17.8	25729	23054	22306	17746	-	-	LCS48TH1S	●	LCS48TH3S	●
	2	2.39	455	21.0	28209	25800	25148	21574	15382	-	LCS48VH1S	●	LCS48VH3S	●
54	3/4	0.92	270	11.0	23384	-	17932	-	-	-	LCS54RH1S	◆	LCS54RH3S	◆
	1	1.20	295	13.1	25550	-	20825	-	-	-	LCS54SH1S	◆	LCS54SH3S	◆
	1 1/2	1.84	340	16.8	29447	-	25449	19183	-	-	LCS54TH1S	◆	LCS54TH3S	◆
	2	2.38	370	19.4	32045	-	28375	23692	-	-	LCS54VH1S	◆	LCS54VH3S	◆
	3	3.60	425	24.0	36809	-	33585	30290	24785	15677	N/A		LCS54WH3S	◆
60	1	1.21	265	11.5	28491	-	22275	-	-	-	LCS60SH1S	◆	LCS60SH3S	◆
	1 1/2	1.75	300	14.3	32254	-	27023	-	-	-	LCS60TH1S	◆	LCS60TH3S	◆
	2	2.44	335	17.1	36017	-	31464	25399	-	-	LCS60VH1S	◆	LCS60VH3S	◆
	3	3.56	380	21.0	40855	-	36826	32244	29351	-	N/A		LCS60WH3S	◆

Performance ratings include the effects of appurtenances (accessories).

Power ratings (BHP) do not include transmission losses.

Performance certified is for installation type A-free inlet, free outlet.

The sound ratings shown are loudness values in fan sones @ 5' (1.5m) in a hemispherical free field calculated per AMCA Standard 301.

Installation Type A: free inlet hemispherical sone levels.

\*Tri-voltage (115-208-230) is standard on 3/4 through 1 1/2 Hp Single phase motors. Tri-voltage is available for the 1/2 Hp motors. Inquire for price and delivery.

Ship Schedules:
● Next Day Shipment From Stock
▲ 3 Day Shipment From Stock
◆ 10 Day Shipment

Please refer to the General Catalog or contact the Factory for our Full Line of products available on standard shipping schedules.

# MODEL CM

## BELT DRIVEN UTILITY VENT SET

### SWSI ARRANGEMENT #10

### CLASS 1 CONSTRUCTION



#### Application

S&P's Model CM is available in a full range of sizes (10 through 36) provides airflow performance from 500 CFM to over 21,000 CFM with static pressure up to 5 in. w.g. This single inlet backward inclined utility fan provides substantial benefits for pressure flow, low power consumption and low noise level, ideal for commercial and industrial applications. Typical applications include either supply or exhaust service for ducted systems in schools, theaters, gymnasiums, manufacturing plants, hotels, office buildings, restaurant hoods, and many other general ventilation applications.

The turbine performance, minimizes unnecessary energy losses resulting in a system with high efficiency.

Its design, manufacture and testing guarantee a long operating life with low maintenance. Also having great versatility in arrangements, and available positions with a complete series of mounting accessories for installation and proper operation of equipment for each application.

The mechanical design and construction determines the maximum operating speed and power. The performance ranges shown on the following pages comply with the Class I operating limits as defined in AMCA standard 99.

**Type:** UTILITY VENT SET

**Type of Wheel:** Backward Inclined

**Rotation:** CW and CCW

**Sizes:** 10, 12, 14, 16, 18, 20, 22, 24, 27, 30, 36

#### Construction

##### Housing & Drive Frame Structure

The unit is solidly built, housing joints are welded intervals, this provides greater strength, accuracy on the boards and makes a robust unit, which is an added value.

##### Wheel

Backward inclined centrifugal wheel is constructed of steel blades protected with a polyester powder coat finish. All wheels are statically and dynamically balanced to ISO 1940 and AMCA 204-G2.5 standards.

##### Paint

The unit is subjected to a coil coating process, where the steel is treated chemically to ensure the adherence of the polyester paint. Subsequently, powder coating is bonded to the parts through an electrostatic process, where after baking the piece takes on its highest characteristics corrosion resistance, with great adhesion properties and impact resistance.

##### Shafts and Bearings

Turned, ground and polished allow steel shafts sized so the first critical speed is at least 30% over the maximum operating speed. Standard bearings are heavy-duty, self-aligning pillow block ball bearings with minimum L10 life in excess of 100,000 hours at maximum cataloged operating conditions.

##### Motors

Heavy-duty ball bearing motors are factory mounted on an adjustable base for ease of service and belt maintenance. Standard motor enclosures are Open Drip Proof (ODP).

#### Drives

V-belt drives are selected for a minimum safety factor of 150% of the driven horsepower. Cast iron motor pulleys are adjustable for final system balancing and are factory set to the required RPM range. Dual groove v-belt drives are standard for motors 5 HP thru 10 HP.

#### Temperature

Standard operating temperature range for cULus 705 units is -20°F to 200°F. For fans with cULus 762 construction the range is -20°F to 400°F.

#### cULus 762 Fan Installation

Model CM is available with the 762 grease listing from UL. The fan will operate with continuous airstream temperatures of 400°F. Per NFPA 96, the fan discharge must be at least 40 inches above the roof line and the duct must be of all welded construction with a minimum distance of 18 inches above the roof line.

**Stock units are either CM, cULus705 listed (non-grease) or CM-RHUL, cULus762 listed (restaurant exhaust).**

**CM - cULus705 units include inlet/L-Flange, weather cover, integral mounting flanges, access door, threaded drain fitting and cULus705 label. CM units have clockwise rotation and top horizontal configuration (CW-TH).**

**CM-RHUL - cULus762 units include inlet/L-Flange, weather cover, threaded drain fitting, access door, integral mounting flanges and cULus762 label. CM-RHUL units have clockwise rotation and upblast configuration (CW-UB).**

#### AMCA SEAL

S&P USA Ventilation Systems, LLC., Div. of Soler & Palau Ventilation Group, certifies that the Models CM shown herein are licensed to bear the AMCA Seal (except CM 10). The ratings shown are based on test and procedures performed in accordance with AMCA Publication 211 and AMCA Publication 311 and comply with the requirement of the AMCA Certified Ratings Program.



STANDARD 705  
STANDARD 762



## Model CM - Discharge Positions

### cULus 705 Clockwise Top Horizontal CW-TH

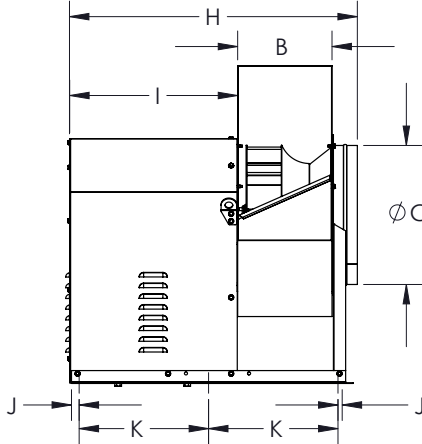
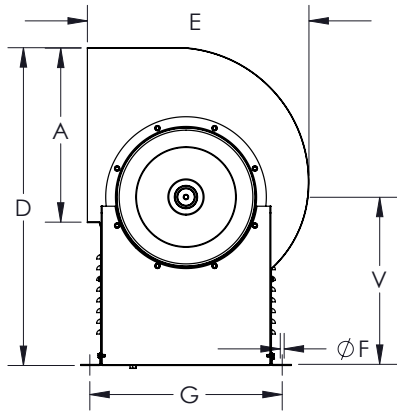

### cULus 762 Clockwise Upblast CW-UB

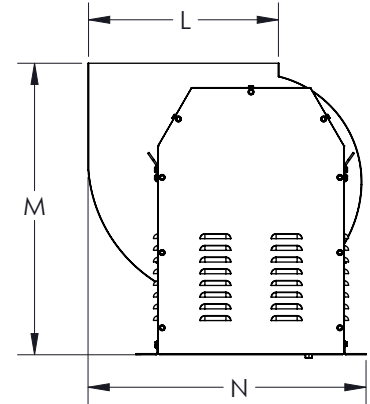

## Dimensions

Model	A	B	C	D	E	F	G	H	I	J	K
10	12 5/8	7 1/16	9 13/16	23 7/8	17 3/16	1/2	16 7/8	25 3/8	15 1/2	1	10 13/16
12	15 7/8	8 3/4	12 3/8	29 3/16	21 3/8	1/2	19 5/8	28 11/16	17 1/16	1	12 1/2
14	17 7/8	9 3/4	14	32 3/4	22 3/4	1/2	19 5/8	30 3/4	17 13/16	1	13 5/16
16	19 15/16	10 13/16	15 3/4	36 3/4	25 1/4	1/2	21 7/8	31 9/16	17 15/16	1	13 7/8
18	22 3/8	12 1/8	17 11/16	40 7/8	28 7/16	1/2	24 3/4	36 15/16	21 9/16	1	16 5/8
20	25 1/8	13 9/16	19 11/16	44 7/8	31 5/16	1/2	27 7/16	38 7/8	21 9/16	1	17 7/16
22	28 1/8	15 3/16	22 1/16	49 3/8	34 15/16	1/2	29 7/8	40 1/8	21 5/8	1	18 1/4
24	31 1/2	17 1/16	24 13/16	57 1/8	39 1/8	1/2	33 1/4	41 15/16	21 5/8	1	19 1/8
27	35 3/8	18 7/8	27 15/16	59	44	1/2	35 1/8	50 1/8	27 1/8	2	19 13/16
30	39 5/8	21	31 1/2	64	49 1/4	1/2	39 7/16	53 13/16	28 11/16	2	23 5/8
36	44 1/2	23 7/16	35 7/16	71 7/8	55 1/4	1/2	44 5/8	54 15/16	27 5/16	2	24 3/16

Model	L	M	N	V
10	12 3/4	21 5/8	20	13-1/4
12	16	26	24 1/4	15-3/4
14	18	28	25 7/8	17-11/16
16	20	31 1/8	29 1/4	19-11/16
18	22 1/2	34 3/8	32 3/4	21-5/8
20	25 1/4	37 1/2	36 1/8	23-5/8
22	28 1/4	41	40 1/8	25-9/16
24	31 5/8	45 7/8	44 5/8	30-1/4
27	35 1/2	55 5/8	50 5/8	28-3/4
30	39 3/4	62 3/8	57 1/8	30
36	44 3/4	70 1/2	64 3/8	33-1/2

## Physical data

Model	Wheel Dia. (in)	Outlet Area (sq. ft.)	Avg. Weight	Shaft Dia.	Max RPM	Max HP	FEG
10	10 1/16	0.625	123	0.75	2998	0.75	-
12	12 11/16	0.97	154	1	2873	2	80
14	14 7/8	1.2	172	1	2672	3	80
16	16	1.49	202	1	2268	3	80
18	17 15/16	1.88	251	1.5	2137	5	80
20	20 3/16	2.33	287	1.5	1823	5	80
22	22 4/16	2.95	389	1.5	1716	7.5	80
24	25 3/16	3.7	465	1.5	1533	10	80
27	28 1/4	4.7	680	1.75	1297	10	80
30	31 7/8	5.76	931	1.75	1093	10	85
36	35 5/8	7.26	1228	2.1875	1061	10	85



## Model CM - Options and Accessories

Model CM	U-Flange Inlet	Outlet Flange	Inlet Guard	Outlet Guard	Shaft Seal
	Stock #	Stock #	Stock #	Stock #	Stock #
10	101882 ▲	104550 ▲	104656 ▲	104630 ▲	104120 ▲
12	101872 ▲	104551 ▲	104657 ▲	104631 ▲	104150 ▲
14	101873 ▲	104552 ▲	104658 ▲	104632 ▲	104150 ▲
16	101874 ◆	104553 ◆	104659 ◆	104633 ◆	104150 ◆
18	101875 ◆	104554 ◆	104660 ◆	104634 ◆	104304 ◆
20	101876 ◆	104555 ◆	104661 ◆	104635 ◆	104304 ◆
22	101877 ◆	104556 ◆	104662 ◆	104636 ◆	104304 ◆
24	101878 ◆	104557 ◆	104663 ◆	104637 ◆	104304 ◆
27	101879 ◆	104558 ◆	104664 ◆	104638 ◆	104421 ◆
30	101880 ◆	104559 ◆	104665 ◆	104639 ◆	104421 ◆
36	101881 ◆	104571 ◆	104666 ◆	104640 ◆	104501 ◆

Model CM	Heavy-Duty Gravity Discharge Shutter	Grease Trough	Vibration Pads		Mounting Rails
			RIS	SPRING	
	Stock #	Stock #	Stock #	Stock #	Stock #
10	104643 ▲	90005891BVS ▲	104669 ▲	104682 ▲	201570 ▲
12	104644 ▲	90005891BVS ▲	104670 ▲	104683 ▲	201571 ▲
14	104645 ▲	90005891BVS ▲	104671 ▲	104684 ▲	201572 ▲
16	104646 ◆	90005891BVS ◆	104672 ◆	104685 ◆	201573 ◆
18	104647 ◆	90005891BVS ◆	104673 ◆	104686 ◆	201574 ◆
20	104648 ◆	90005891BVS ◆	104674 ◆	104687 ◆	201575 ◆
22	104649 ◆	90005891BVS ◆	104675 ◆	104688 ◆	201576 ◆
24	104650 ◆	90005891BVS ◆	104676 ◆	104689 ◆	201577 ◆
27	104651 ◆	90005891BVS ◆	104677 ◆	104690 ◆	201578 ◆
30	104652 ◆	90005891BVS ◆	104678 ◆	104691 ◆	201579 ◆
36	104653 ◆	90005891BVS ◆	104679 ◆	104692 ◆	201580 ◆

Ship Schedules:
● Next Day Shipment From Stock
▲ 3 Day Shipment From Stock
◆ 10 Day Shipment

Please refer to the General Catalog or contact the Factory for our Full Line of products available on standard shipping schedules.

# MODEL CM

## Belt Driven Utility Vent Set SWSI Arrangement #10 Class 1 Construction

HP	Stock Number	RPM	Max BHP	CFM at Static Pressure (Inches w.g.)											
				1/2	3/4	1	1 1/4	1 1/2	2	2 1/2	3	4	5		
10	1/4 CM10ML__S ▲	1325	0.07	507	270	-	-	-	-	-	-	-	-	-	
		1450	0.09	610	455	-	-	-	-	-	-	-	-	-	
		1550	0.11	686	556	-	-	-	-	-	-	-	-	-	
		1675	0.14	777	665	526	-	-	-	-	-	-	-	-	
	1/4 CM10MH__S ▲	1800	0.17	865	765	651	500	-	-	-	-	-	-	-	
		1925	0.21	950	860	761	643	480	-	-	-	-	-	-	
		2050	0.25	1033	951	862	762	642	-	-	-	-	-	-	
	1/3 CM10PH__S ▲	2100	0.27	1066	986	900	806	696	-	-	-	-	-	-	
		2175	0.3	1115	1038	957	869	770	-	-	-	-	-	-	
		2250	0.33	1163	1090	1013	930	839	596	-	-	-	-	-	
	1/2 CM10QH__S ▲	2300	0.35	1196	1124	1049	970	882	663	-	-	-	-	-	
		2375	0.39	1244	1175	1103	1028	946	750	-	-	-	-	-	
		2475	0.44	1307	1242	1174	1103	1027	853	604	-	-	-	-	
	3/4 CM10RH__S ▲	2575	0.49	1370	1307	1243	1176	1105	947	745	-	-	-	-	
		2625	0.52	1401	1340	1277	1212	1143	992	805	-	-	-	-	
		2725	0.58	1464	1405	1345	1283	1218	1078	912	683	-	-	-	
	12	1/4 CM12MH__S ▲	2850	0.67	1541	1486	1428	1370	1309	1180	1033	852	-	-	
			2950	0.74	1603	1549	1494	1438	1380	1258	1122	963	-	-	
			1025	0.1	754	-	-	-	-	-	-	-	-	-	-
			1125	0.13	923	-	-	-	-	-	-	-	-	-	-
		1/3 CM12PH__S ▲	1250	0.18	1114	914	-	-	-	-	-	-	-	-	-
			1375	0.24	1293	1126	924	-	-	-	-	-	-	-	-
		1/2 CM12QH__S ▲	1450	0.28	1397	1243	1067	838	-	-	-	-	-	-	-
			1525	0.33	1499	1356	1198	1008	733	-	-	-	-	-	-
3/4 CM12RH__S ▲		1600	0.38	1599	1465	1320	1155	947	-	-	-	-	-	-	
		1675	0.44	1698	1571	1437	1288	1114	-	-	-	-	-	-	
1 CM12SH__S ▲		1750	0.5	1795	1676	1550	1413	1260	806	-	-	-	-	-	
		1850	0.59	1924	1812	1695	1572	1437	1099	-	-	-	-	-	
1 1/2 CM12TH__S ▲		1925	0.66	2020	1912	1802	1685	1561	1267	-	-	-	-	-	
		2000	0.74	2115	2012	1906	1796	1680	1416	1047	-	-	-	-	
2 CM12VH__S ▲		2050	0.8	2178	2077	1975	1869	1758	1508	1184	-	-	-	-	
		2125	0.89	2272	2175	2077	1976	1871	1640	1359	-	-	-	-	
1 CM12SH__S ▲		2200	0.99	2365	2272	2178	2081	1981	1766	1513	1173	-	-	-	
		2275	1.1	2458	2368	2278	2185	2089	1886	1656	1368	-	-	-	
1 1/2 CM12TH__S ▲		2350	1.21	2551	2464	2376	2287	2196	2003	1789	1536	-	-	-	
		2450	1.37	2674	2591	2507	2422	2335	2154	1958	1735	-	-	-	
2 CM12VH__S ▲		2525	1.5	2766	2685	2604	2522	2438	2265	2079	1873	1309	-	-	
		2600	1.64	2858	2779	2700	2621	2540	2374	2197	2004	1515	-	-	
2 CM12VH__S ▲		2675	1.78	2949	2873	2796	2719	2641	2481	2312	2130	1690	-	-	
		2775	1.99	3070	2997	2923	2849	2774	2622	2462	2292	1899	1305	-	

Performance certified is for installation type B - free inlet, ducted outlet. Performance ratings do not include the effects of appurtenances (accessories). Power rating (BHP) does not include transmission losses.

Ship Schedules:
▲ 3 Day Shipment From Stock
◆ 10 Day Shipment

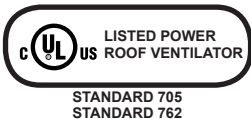

S&P USA Ventilation Systems, LLC., Div. of Soler & Palau Ventilation Group, certifies that the Models CM shown herein are licensed to bear the AMCA Seal (except CM 10). The ratings shown are based on test and procedures performed in accordance with AMCA Publication 211 and AMCA Publication 311 and comply with the requirement of the AMCA Certified Ratings Program.

Please refer to the General Catalog or contact the Factory for our Full Line of products available on standard shipping schedules.

<b>MODEL CM</b>		<b>Belt Driven Vent Set SWSI Arrangement #10 Class 1 Construction</b>												
HP	Stock Number	RPM	Max BHP	CFM at Static Pressure (Inches w.g.)										
				1/2	3/4	1	1 1/4	1 1/2	2	2 1/2	3	4	5	
14	1/4	CM14MH_S ▲	950	0.14	1061	652	-	-	-	-	-	-	-	-
			1050	0.19	1277	1019	-	-	-	-	-	-	-	-
			1150	0.25	1477	1269	985	-	-	-	-	-	-	-
	1/3	CM14PH_S ▲	1200	0.29	1574	1381	1142	-	-	-	-	-	-	-
			1250	0.32	1669	1488	1276	962	-	-	-	-	-	-
	1/2	CM14QH_S ▲	1300	0.37	1763	1592	1400	1149	-	-	-	-	-	-
			1375	0.43	1902	1743	1571	1368	1079	-	-	-	-	-
			1445	0.5	2030	1880	1722	1545	1325	-	-	-	-	-
	3/4	CM14RH_S ▲	1500	0.56	2130	1986	1836	1673	1482	-	-	-	-	-
			1575	0.65	2264	2128	1988	1839	1673	1189	-	-	-	-
			1650	0.75	2397	2267	2135	1997	1848	1472	-	-	-	-
	1	CM14SH_S ▲	1725	0.86	2530	2405	2280	2150	2014	1692	1128	-	-	-
1800			0.97	2661	2541	2422	2300	2172	1886	1491	-	-	-	
1 1/2	CM14TH_S ▲	1875	1.1	2792	2677	2562	2446	2326	2065	1739	1114	-	-	
		1975	1.28	2965	2855	2746	2637	2526	2289	2015	1645	-	-	
		2075	1.49	3137	3032	2928	2825	2720	2501	2259	1967	-	-	
2	CM14VH_S ▲	2150	1.65	3265	3164	3064	2964	2863	2655	2431	2172	-	-	
		2225	1.84	3393	3295	3198	3101	3005	2806	2595	2360	1670	-	
		2290	2	3504	3408	3313	3220	3126	2935	2734	2514	1934	-	
3	CM14WH_S ▲	2400	2.3	3691	3598	3508	3418	3329	3148	2961	2762	2283	-	
		2500	2.61	3860	3771	3684	3597	3511	3339	3162	2977	2553	1924	
		2600	2.93	4028	3942	3858	3775	3692	3527	3359	3185	2799	2299	

Ship Schedules:
● Next Day Shipment From Stock
▲ 3 Day Shipment From Stock
◆ 10 Day Shipment

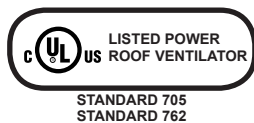

S&P USA Ventilation Systems, LLC., Div. of Soler & Palau Ventilation Group, certifies that the Models CM shown herein are licensed to bear the AMCA Seal (except CM 10). The ratings shown are based on test and procedures performed in accordance with AMCA Publication 211 and AMCA Publication 311 and comply with the requirement of the AMCA Certified Ratings Program.

Performance certified is for installation type B - free inlet, ducted outlet. Performance ratings do not include the effects of appurtenances (accessories). Power rating (BHP) does not include transmission losses.

Please refer to the General Catalog or contact the Factory for our Full Line of products available on standard shipping schedules.

<b>MODEL CM</b>		<b>Belt Driven Vent Set SWSI Arrangement #10 Class 1 Construction</b>												
HP	Stock Number	RPM	Max BHP	CFM at Static Pressure (Inches w.g.)										
				1/2	3/4	1	1 1/4	1 1/2	2	2 1/2	3	4	5	
1/4	CM16MH__S ◆	825	0.16	1222	-	-	-	-	-	-	-	-	-	-
		900	0.21	1455	1085	-	-	-	-	-	-	-	-	-
		950	0.25	1601	1287	-	-	-	-	-	-	-	-	-
1/3	CM16PH__S ◆	1000	0.29	1741	1462	-	-	-	-	-	-	-	-	-
		1050	0.33	1879	1623	1300	-	-	-	-	-	-	-	-
1/2	CM16QH__S ◆	1100	0.38	2013	1775	1497	1061	-	-	-	-	-	-	-
		1150	0.44	2146	1922	1672	1346	-	-	-	-	-	-	-
		1200	0.5	2276	2064	1835	1561	-	-	-	-	-	-	-
3/4	CM16RH__S ◆	1250	0.56	2406	2203	1989	1747	1428	-	-	-	-	-	-
		1300	0.63	2534	2339	2138	1917	1651	-	-	-	-	-	-
		1375	0.75	2724	2540	2353	2155	1933	-	-	-	-	-	-
1	CM16SH__S ◆	1425	0.83	2850	2671	2493	2306	2103	1553	-	-	-	-	-
		1475	0.92	2975	2802	2630	2453	2264	1796	-	-	-	-	-
		1510	0.99	3062	2893	2725	2554	2373	1943	-	-	-	-	-
1 1/2	CM16TH__S ◆	1550	1.07	3162	2996	2832	2667	2494	2097	1458	-	-	-	-
		1625	1.23	3347	3187	3031	2875	2714	2361	1898	-	-	-	-
		1700	1.41	3531	3377	3227	3078	2927	2604	2219	1613	-	-	-
		1735	1.5	3617	3465	3318	3172	3025	2713	2352	1844	-	-	-
2	CM16VH__S ◆	1775	1.6	3714	3565	3421	3278	3135	2835	2496	2054	-	-	-
		1850	1.82	3897	3752	3613	3476	3339	3057	2749	2382	-	-	-
		1900	1.97	4018	3876	3740	3606	3473	3201	2910	2574	-	-	-
3	CM16WH__S ◆	1975	2.2	4199	4062	3930	3800	3672	3413	3141	2840	1950	-	-
		2075	2.56	4440	4307	4180	4056	3934	3689	3437	3167	2491	-	-
		2175	2.95	4680	4552	4429	4310	4193	3960	3723	3476	2901	1916	-

16

Ship Schedules:
● Next Day Shipment From Stock
▲ 3 Day Shipment From Stock
◆ 10 Day Shipment



S&P USA Ventilation Systems, LLC., Div. of Soler & Palau Ventilation Group, certifies that the Models CM shown herein are licensed to bear the AMCA Seal (except CM 10). The ratings shown are based on test and procedures performed in accordance with AMCA Publication 211 and AMCA Publication 311 and comply with the requirement of the AMCA Certified Ratings Program.

Performance certified is for installation type B - free inlet, ducted outlet. Performance ratings do not include the effects of appurtenances (accessories). Power rating (BHP) does not include transmission losses.

Please refer to the General Catalog or contact the Factory for our Full Line of products available on standard shipping schedules.

<b>MODEL CM</b>		<b>Belt Driven Vent Set SWSI Arrangement #10 Class 1 Construction</b>												
HP	Stock Number	RPM	Max BHP	CFM at Static Pressure (Inches w.g.)										
				1/2	3/4	1	1 1/4	1 1/2	2	2 1/2	3	4	5	
1/4	CM18MH__S ♦	700	0.18	1438	-	-	-	-	-	-	-	-	-	-
		750	0.22	1680	1052	-	-	-	-	-	-	-	-	-
		775	0.25	1793	1269	-	-	-	-	-	-	-	-	-
1/3	CM18PH__S ♦	800	0.27	1902	1439	-	-	-	-	-	-	-	-	-
		850	0.33	2113	1723	-	-	-	-	-	-	-	-	-
1/2	CM18QH__S ♦	875	0.36	2216	1850	-	-	-	-	-	-	-	-	-
		925	0.42	2416	2087	1669	-	-	-	-	-	-	-	-
		975	0.5	2611	2309	1955	-	-	-	-	-	-	-	-
3/4	CM18RH__S ♦	1025	0.58	2802	2522	2207	1808	-	-	-	-	-	-	-
		1075	0.66	2991	2727	2441	2104	1625	-	-	-	-	-	-
		1120	0.75	3158	2908	2641	2340	1962	-	-	-	-	-	-
1	CM18SH__S ♦	1175	0.87	3360	3124	2876	2606	2291	-	-	-	-	-	-
		1225	0.98	3542	3316	3083	2833	2554	1720	-	-	-	-	-
1 1/2	CM18TH__S ♦	1300	1.17	3813	3601	3384	3158	2914	2309	-	-	-	-	-
		1350	1.32	3991	3787	3580	3366	3139	2608	-	-	-	-	-
		1400	1.47	4169	3972	3774	3570	3357	2875	2201	-	-	-	-
2	CM18VH__S ♦	1450	1.63	4345	4155	3965	3770	3568	3124	2560	-	-	-	-
		1500	1.8	4521	4337	4153	3967	3774	3360	2862	2104	-	-	-
		1550	1.99	4696	4518	4340	4161	3977	3586	3135	2538	-	-	-
3	CM18WH__S ♦	1625	2.29	4957	4787	4618	4447	4274	3912	3511	3030	-	-	-
		1675	2.5	5130	4965	4801	4636	4469	4123	3747	3312	-	-	-
		1725	2.74	5303	5142	4983	4823	4662	4329	3974	3574	-	-	-
		1775	2.99	5475	5319	5164	5009	4852	4532	4194	3822	2818	-	-
5	CM18XH__S ♦	1900	3.66	5904	5757	5612	5467	5322	5028	4723	4399	3636	-	-
		2000	4.28	6245	6105	5967	5829	5691	5414	5130	4833	4168	3269	-
		2100	4.95	6585	6451	6319	6188	6057	5794	5526	5250	4652	3925	-

Performance certified is for installation type B - free inlet, ducted outlet. Performance ratings do not include the effects of appurtenances (accessories). Power rating (BHP) does not include transmission losses.

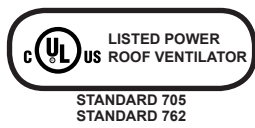

S&P USA Ventilation Systems, LLC., Div. of Soler & Palau Ventilation Group, certifies that the Models CM shown herein are licensed to bear the AMCA Seal (except CM 10). The ratings shown are based on test and procedures performed in accordance with AMCA Publication 211 and AMCA Publication 311 and comply with the requirement of the AMCA Certified Ratings Program.

Ship Schedules:	
▲	3 Day Shipment From Stock
♦	10 Day Shipment

**How to order:**

<b>Model Number</b>	<b>Motor HP</b>	<b>RPM</b>	<b>Phase</b>	<b>UL</b>	<b>Stock</b>
<b>Example: CM24</b>	<b>P</b>	<b>H</b>	<b>1</b>	<b>U</b>	<b>S</b>
CM24	P=1/3	L=Low	1 or 3	U=cULus705	S=Stock
	Q=1/2	M=Medium		R=cULus762	
	R=3/4	H=High			
	S=1				
	T=1 1/2				
	V=2				
	W=3				
	X=5				
	Y=7 1/2				
	Z=10				

Indicates Customer Provided Information

Please refer to the General Catalog or contact the Factory for our Full Line of products available on standard shipping schedules.

<b>MODEL CM</b>		<b>Belt Driven Utility Vent Set SWSI Arrangement #10 Class 1 Construction</b>												
HP	Stock Number	RPM	Max BHP	CFM at Static Pressure (Inches w.g.)										
				1/2	3/4	1	1 1/4	1 1/2	2	2 1/2	3	4	5	
1/3	CM20PH__S ♦	625	0.21	1795	-	-	-	-	-	-	-	-	-	-
		675	0.27	2137	1368	-	-	-	-	-	-	-	-	-
		720	0.33	2418	1840	-	-	-	-	-	-	-	-	-
1/2	CM20QH__S ♦	775	0.42	2743	2267	-	-	-	-	-	-	-	-	-
		825	0.5	3027	2606	2068	-	-	-	-	-	-	-	-
3/4	CM20RH__S ♦	850	0.55	3166	2765	2279	1381	-	-	-	-	-	-	-
		900	0.65	3439	3071	2654	2099	-	-	-	-	-	-	-
		940	0.75	3654	3307	2926	2464	1705	-	-	-	-	-	-
1	CM20SH__S ♦	975	0.83	3840	3508	3152	2740	2184	-	-	-	-	-	-
		1025	0.97	4102	3789	3461	3097	2659	-	-	-	-	-	-
		1040	1	4180	3872	3551	3199	2783	-	-	-	-	-	-
1 1/2	CM20TH__S ♦	1125	1.28	4617	4335	4046	3742	3408	2512	-	-	-	-	-
		1175	1.46	4872	4601	4328	4043	3738	2997	-	-	-	-	-
2	CM20VH__S ♦	1200	1.55	4998	4734	4466	4190	3898	3207	-	-	-	-	-
		1250	1.75	5250	4996	4740	4479	4206	3590	2720	-	-	-	-
		1300	1.97	5500	5255	5011	4762	4505	3942	3229	-	-	-	-
3	CM20WH__S ♦	1350	2.2	5749	5513	5277	5040	4796	4273	3652	2735	-	-	-
		1425	2.59	6120	5895	5672	5449	5222	4745	4210	3546	-	-	-
		1500	3.03	6489	6274	6062	5851	5637	5195	4717	4166	-	-	-
5	CM20XH__S ♦	1600	3.68	6978	6775	6576	6378	6179	5773	5347	4880	3651	-	-
		1675	4.21	7342	7148	6957	6767	6578	6194	5796	5372	4353	-	-
		1750	4.81	7705	7519	7335	7153	6972	6607	6233	5840	4946	3627	-
		1770	4.98	7802	7617	7436	7256	7076	6716	6347	5962	5093	3873	-

Performance certified is for installation type B - free inlet, ducted outlet. Performance ratings do not include the effects of appurtenances (accessories). Power rating (BHP) does not include transmission losses.

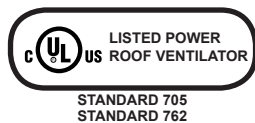

S&P USA Ventilation Systems, LLC., Div. of Soler & Palau Ventilation Group, certifies that the Models CM shown herein are licensed to bear the AMCA Seal (except CM 10). The ratings shown are based on test and procedures performed in accordance with AMCA Publication 211 and AMCA Publication 311 and comply with the requirement of the AMCA Certified Ratings Program.

Ship Schedules:
▲ 3 Day Shipment From Stock
♦ 10 Day Shipment

**How to order:**

Model Number	Motor HP	RPM	Phase	UL	Stock
<b>Example: CM24</b>	<b>P</b>	<b>H</b>	<b>1</b>	<b>U</b>	<b>S</b>
CM24	P=1/3	L=Low	1 or 3	U=cULus705	S=Stock
	Q=1/2	M=Medium		R=cULus762	
	R=3/4	H=High			
	S=1				
	T=1 1/2				
	V=2				
	W=3				
	X=5				
	Y=7 1/2				
	Z=10				

Indicates Customer Provided Information

<b>MODEL CM</b>		<b>Belt Driven Utility Vent Set SWSI Arrangement #10 Class 1 Construction</b>												
HP	Stock Number	RPM	Max BHP	CFM at Static Pressure (Inches w.g.)										
				1/2	3/4	1	1 1/4	1 1/2	2	2 1/2	3	4	5	
22	1/3	CM22PH__S ♦	575	0.29	2384	-	-	-	-	-	-	-	-	-
			590	0.31	2527	1293	-	-	-	-	-	-	-	-
			600	0.33	2620	1593	-	-	-	-	-	-	-	-
	1/2	CM22QH__S ♦	620	0.37	2799	1952	-	-	-	-	-	-	-	-
			650	0.42	3059	2347	-	-	-	-	-	-	-	-
			680	0.48	3309	2677	-	-	-	-	-	-	-	-
	3/4	CM22RH__S ♦	695	0.52	3431	2830	-	-	-	-	-	-	-	-
			725	0.59	3672	3118	2386	-	-	-	-	-	-	-
			755	0.66	3908	3390	2762	-	-	-	-	-	-	-
			785	0.75	4140	3652	3090	-	-	-	-	-	-	-
	1	CM22SH__S ♦	800	0.79	4255	3779	3242	2514	-	-	-	-	-	-
			830	0.88	4483	4029	3533	2920	-	-	-	-	-	-
860			0.98	4709	4274	3809	3266	2484	-	-	-	-	-	
1 1/2	CM22TH__S ♦	890	1.09	4933	4514	4075	3581	2950	-	-	-	-	-	
		920	1.2	5154	4750	4332	3875	3328	-	-	-	-	-	
		950	1.32	5375	4983	4583	4154	3664	-	-	-	-	-	
		980	1.45	5593	5213	4829	4424	3973	-	-	-	-	-	
2	CM22VH__S ♦	1025	1.66	5919	5555	5190	4813	4406	3369	-	-	-	-	
		1055	1.81	6135	5780	5427	5065	4681	3756	-	-	-	-	
		1085	1.97	6350	6004	5661	5312	4946	4101	-	-	-	-	
3	CM22WH__S ♦	1130	2.23	6671	6337	6008	5676	5333	4572	3535	-	-	-	
		1160	2.41	6884	6557	6236	5914	5584	4865	3955	-	-	-	
		1220	2.8	7307	6994	6688	6383	6074	5421	4660	3581	-	-	
		1250	3.01	7518	7211	6912	6614	6314	5687	4976	4051	-	-	
5	CM22XH__S ♦	1295	3.35	7833	7535	7245	6958	6670	6075	5421	4635	-	-	
		1340	3.71	8147	7857	7575	7297	7020	6452	5843	5144	-	-	
		1400	4.23	8564	8284	8013	7746	7480	6943	6379	5758	3975	-	
		1475	4.95	9083	8815	8554	8300	8047	7542	7021	6466	5102	-	
7 1/2	CM22YH__S ♦	1550	5.74	9600	9342	9092	8848	8606	8127	7639	7131	5968	4130	
		1610	6.44	10012	9761	9519	9282	9049	8587	8122	7642	6584	5176	
		1685	7.38	10525	10284	10050	9822	9598	9155	8713	8263	7299	6139	

Performance certified is for installation type B - free inlet, ducted outlet. Performance ratings do not include the effects of appurtenances (accessories). Power rating (BHP) does not include transmission losses.

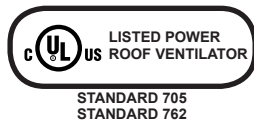

S&P USA Ventilation Systems, LLC., Div. of Soler & Palau Ventilation Group, certifies that the Models CM shown herein are licensed to bear the AMCA Seal (except CM 10). The ratings shown are based on test and procedures performed in accordance with AMCA Publication 211 and AMCA Publication 311 and comply with the requirement of the AMCA Certified Ratings Program.

Ship Schedules:	
▲	3 Day Shipment From Stock
♦	10 Day Shipment

Please refer to the General Catalog or contact the Factory for our Full Line of products available on standard shipping schedules.



<b>MODEL CM</b>		<b>Belt Driven Vent Set SWSI Arrangement #10 Class 1 Construction</b>												
HP	Stock Number	RPM	Max BHP	CFM at Static Pressure (Inches w.g.)										
				1/2	3/4	1	1 1/4	1 1/2	2	2 1/2	3	4	5	
24	1/2	CM24QH__S ♦	500	0.35	3035	-	-	-	-	-	-	-	-	-
			525	0.41	3383	1803	-	-	-	-	-	-	-	-
			555	0.48	3773	2756	-	-	-	-	-	-	-	-
	3/4	CM24RH__S ♦	575	0.54	4022	3131	-	-	-	-	-	-	-	-
			640	0.74	4793	4103	3164	-	-	-	-	-	-	-
	1	CM24SH__S ♦	650	0.78	4907	4237	3363	-	-	-	-	-	-	-
			675	0.87	5191	4561	3800	-	-	-	-	-	-	-
			700	0.97	5471	4874	4188	3181	-	-	-	-	-	-
	1 1/2	CM24TH__S ♦	750	1.2	6021	5476	4885	4172	2960	-	-	-	-	-
			805	1.48	6615	6112	5588	5005	4283	-	-	-	-	-
	2	CM24VH__S ♦	825	1.6	6828	6338	5833	5281	4626	-	-	-	-	-
			850	1.74	7094	6619	6133	5613	5019	-	-	-	-	-
880			1.93	7410	6951	6487	5997	5456	3878	-	-	-	-	
3	CM24WH__S ♦	925	2.25	7882	7444	7006	6553	6068	4864	-	-	-	-	
		975	2.63	8401	7984	7570	7149	6708	5696	4067	-	-	-	
		1020	3.00	8866	8465	8069	7671	7260	6355	5167	-	-	-	
5	CM24XH__S ♦	1100	3.78	9685	9309	8941	8574	8203	7420	6520	5297	-	-	
		1150	4.32	10194	9831	9478	9127	8775	8045	7239	6261	-	-	
		1205	4.97	10751	10402	10063	9728	9393	8708	7976	7142	-	-	
7 1/2	CM24YH__S ♦	1300	6.23	11707	11379	11061	10749	10439	9815	9168	8474	6726	-	
		1385	7.54	12557	12247	11945	11649	11357	10774	10182	9563	8150	5946	
10	CM24ZH__S ♦	1425	8.22	12956	12653	12358	12069	11785	11219	10646	10055	8739	6946	
		1475	9.12	13453	13158	12872	12592	12316	11769	11219	10656	9435	7915	
		1520	9.97	13900	13612	13333	13060	12791	12259	11727	11186	10034	8669	

Performance certified is for installation type B - free inlet, ducted outlet. Performance ratings do not include the effects of appurtenances (accessories). Power rating (BHP) does not include transmission losses.



S&P USA Ventilation Systems, LLC., Div. of Soler & Palau Ventilation Group, certifies that the Models CM shown herein are licensed to bear the AMCA Seal (except CM 10). The ratings shown are based on test and procedures performed in accordance with AMCA Publication 211 and AMCA Publication 311 and comply with the requirement of the AMCA Certified Ratings Program.

Ship Schedules:
▲ 3 Day Shipment From Stock
◆ 10 Day Shipment

**How to order:**

	<b>Model Number</b>	<b>Motor HP</b>	<b>RPM</b>	<b>Phase</b>	<b>UL</b>	<b>Stock</b>
<b>Example:</b>	<b>CM24</b>	<b>P</b>	<b>H</b>	<b>1</b>	<b>U</b>	<b>S</b>
	CM24	P=1/3	L=Low	1 or 3	U=cULus705	S=Stock
		Q=1/2	M=Medium		R=cULus762	
		R=3/4	H=High			
		S=1				
		T=1 1/2				
		V=2				
		W=3				
		X=5				
		Y=7 1/2				
		Z=10				

Indicates Customer Provided Information

<b>MODEL CM</b>		<b>Belt Driven Vent Set SWSI Arrangement #10 Class 1 Construction</b>												
HP	Stock Number	RPM	Max BHP	CFM at Static Pressure (Inches w.g.)										
				1/2	3/4	1	1 1/4	1 1/2	2	2 1/2	3	4	5	
1/2	CM27QH__S ♦	425	0.35	3243	-	-	-	-	-	-	-	-	-	-
		450	0.43	3787	-	-	-	-	-	-	-	-	-	-
		470	0.5	4185	2462	-	-	-	-	-	-	-	-	-
3/4	CM27RH__S ♦	490	0.57	4561	3181	-	-	-	-	-	-	-	-	-
		510	0.65	4921	3720	-	-	-	-	-	-	-	-	-
		530	0.73	5268	4187	-	-	-	-	-	-	-	-	-
1	CM27SH__S ♦	550	0.82	5607	4615	3148	-	-	-	-	-	-	-	-
		570	0.91	5937	5016	3795	-	-	-	-	-	-	-	-
		590	1.02	6261	5398	4322	-	-	-	-	-	-	-	-
1 1/2	CM27TH__S ♦	625	1.21	6816	6033	5118	3872	-	-	-	-	-	-	-
		650	1.36	7203	6468	5631	4589	-	-	-	-	-	-	-
		675	1.52	7586	6890	6115	5197	3908	-	-	-	-	-	-
2	CM27VH__S ♦	700	1.69	7963	7303	6578	5748	4702	-	-	-	-	-	-
		725	1.88	8336	7707	7025	6261	5352	-	-	-	-	-	-
		745	2.04	8633	8025	7373	6653	5820	-	-	-	-	-	-
3	CM27WH__S ♦	775	2.3	9073	8496	7882	7215	6468	4343	-	-	-	-	-
		820	2.72	9726	9188	8623	8019	7362	5747	-	-	-	-	-
		850	3.04	10157	9643	9104	8535	7923	6486	-	-	-	-	-
5	CM27XH__S ♦	900	3.6	10870	10389	9890	9367	8815	7575	5965	-	-	-	-
		950	4.24	11575	11124	10658	10174	9667	8561	7244	5352	-	-	-
		1010	5.09	12415	11994	11562	11115	10653	9664	8546	7187	-	-	-
7 1/2	CM27YH__S ♦	1040	5.56	12833	12425	12008	11578	11134	10192	9145	7920	-	-	-
		1100	6.58	13663	13280	12889	12489	12077	11213	10277	9230	6297	-	-
		1160	7.71	14489	14128	13760	13384	13000	12200	11347	10418	8137	-	-
10	CM27ZH__S ♦	1180	8.12	14763	14408	14048	13680	13303	12522	11693	10796	8645	-	-
		1225	9.09	15379	15038	14692	14340	13981	13238	12456	11621	9693	6852	-
		1270	10.13	15992	15665	15332	14995	14651	13943	13201	12417	10655	8355	-

Performance certified is for installation type B - free inlet, ducted outlet. Performance ratings do not include the effects of appurtenances (accessories). Power rating (BHP) does not include transmission losses.

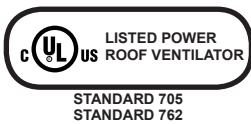

AMCA WORLDWIDE CERTIFIED RATINGS  
SOUND AND AIR PERFORMANCE  
FEG

S&P USA Ventilation Systems, LLC., Div. of Soler & Palau Ventilation Group, certifies that the Models CM shown herein are licensed to bear the AMCA Seal (except CM 10). The ratings shown are based on test and procedures performed in accordance with AMCA Publication 211 and AMCA Publication 311 and comply with the requirement of the AMCA Certified Ratings Program.

Ship Schedules:
▲ 3 Day Shipment From Stock
♦ 10 Day Shipment

<b>MODEL CM</b>		<b>Belt Driven Vent Set SWSI Arrangement #10 Class 1 Construction</b>												
HP	Stock Number	RPM	Max BHP	CFM at Static Pressure (Inches w.g.)										
				1/2	3/4	1	1 1/4	1 1/2	2	2 1/2	3	4	5	
30	3/4	CM30RH_S ♦	390	0.52	4512	-	-	-	-	-	-	-	-	-
			415	0.64	5213	-	-	-	-	-	-	-	-	-
			435	0.74	5732	4041	-	-	-	-	-	-	-	-
	1	CM30SH_S ♦	450	0.82	6105	4631	-	-	-	-	-	-	-	-
			465	0.91	6467	5136	-	-	-	-	-	-	-	-
			485	1.04	6938	5741	3740	-	-	-	-	-	-	-
	1 1/2	CM30TH_S ♦	500	1.14	7283	6162	4563	-	-	-	-	-	-	-
			525	1.32	7848	6822	5536	-	-	-	-	-	-	-
			550	1.52	8401	7449	6334	4656	-	-	-	-	-	-
	2	CM30VH_S ♦	565	1.65	8728	7813	6771	5363	-	-	-	-	-	-
			580	1.78	9052	8169	7187	5944	-	-	-	-	-	-
			605	2.02	9588	8751	7847	6779	5233	-	-	-	-	-
3	CM30WH_S ♦	620	2.17	9906	9094	8227	7233	5920	-	-	-	-	-	
		660	2.62	10746	9989	9203	8345	7340	-	-	-	-	-	
		695	3.06	11471	10755	10022	9244	8378	5851	-	-	-	-	
5	CM30XH_S ♦	720	3.41	11985	11294	10593	9859	9062	7001	-	-	-	-	
		770	4.16	13004	12357	11709	11043	10342	8721	6124	-	-	-	
		820	5.03	14013	13403	12797	12182	11547	10157	8397	-	-	-	
7 1/2	CM30YH_S ♦	840	5.41	14414	13818	13226	12629	12015	10691	9087	6474	-	-	
		890	6.43	15412	14846	14287	13727	13159	11963	10611	8893	-	-	
		940	7.58	16403	15865	15334	14806	14273	13172	11976	10587	-	-	
10	CM30ZH_S ♦	970	8.33	16995	16472	15957	15444	14930	13875	12749	11482	7479	-	
		1000	9.12	17586	17076	16575	16078	15580	14566	13497	12323	9127	-	
		1030	9.97	18174	17678	17190	16707	16225	15247	14227	13126	10356	-	

Performance certified is for installation type B - free inlet, ducted outlet. Performance ratings do not include the effects of appurtenances (accessories). Power rating (BHP) does not include transmission losses.

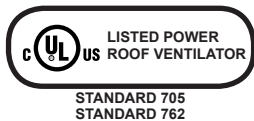

S&P USA Ventilation Systems, LLC., Div. of Soler & Palau Ventilation Group, certifies that the Models CM shown herein are licensed to bear the AMCA Seal (except CM 10). The ratings shown are based on test and procedures performed in accordance with AMCA Publication 211 and AMCA Publication 311 and comply with the requirement of the AMCA Certified Ratings Program.

Ship Schedules:	
▲	3 Day Shipment From Stock
♦	10 Day Shipment

**How to order:**

Model Number	Motor HP	RPM	Phase	UL	Stock
<b>Example: CM24</b>	<b>P</b>	<b>H</b>	<b>1</b>	<b>U</b>	<b>S</b>
CM24	P=1/3	L=Low	1 or 3	U=cULus705	S=Stock
	Q=1/2	M=Medium		R=cULus762	
	R=3/4	H=High			
	S=1				
	T=1 1/2				
	V=2				
	W=3				
	X=5				
	Y=7 1/2				
	Z=10				

Indicates Customer Provided Information

<b>MODEL CM</b>		<b>Belt Driven Vent Set SWSI Arrangement #10 Class 1 Construction</b>												
HP	Stock Number	RPM	Max BHP	CFM at Static Pressure (Inches w.g.)										
				1/2	3/4	1	1 1/4	1 1/2	2	2 1/2	3	4	5	
<b>36</b>	1	CM36SH__S◆	340	0.59	5308	-	-	-	-	-	-	-	-	-
			380	0.86	6882	-	-	-	-	-	-	-	-	-
			400	1.01	7588	5732	-	-	-	-	-	-	-	-
	1 1/2	CM36TH__S◆	420	1.18	8264	6656	-	-	-	-	-	-	-	-
			440	1.36	8919	7474	-	-	-	-	-	-	-	-
			460	1.55	9558	8231	6523	-	-	-	-	-	-	-
	2	CM36VH__S◆	470	1.65	9872	8594	7014	-	-	-	-	-	-	-
			485	1.82	10338	9124	7687	-	-	-	-	-	-	-
			500	1.99	10798	9639	8310	-	-	-	-	-	-	-
	3	CM36WH__S◆	525	2.3	11554	10472	9276	7820	-	-	-	-	-	-
			550	2.65	12299	11281	10183	8922	7255	-	-	-	-	-
			575	3.03	13035	12071	11050	9918	8561	-	-	-	-	-
	5	CM36XH__S◆	600	3.44	13763	12846	11888	10851	9669	-	-	-	-	-
			640	4.17	14914	14061	13183	12256	11249	8660	-	-	-	-
			680	5.01	16051	15253	14438	13592	12697	10615	-	-	-	-
	7 1/2	CM36YH__S◆	700	5.46	16615	15841	15054	14242	13389	11463	-	-	-	-
			740	6.45	17736	17005	16266	15511	14729	13026	10942	-	-	-
			785	7.7	18988	18299	17606	16903	16183	14654	12913	10672	-	-
	10	CM36ZH__S◆	800	8.15	19402	18727	18048	17360	16658	15176	13514	11465	-	-
			830	9.11	20230	19579	18926	18266	17595	16195	14663	12876	-	-
			860	10.13	21053	20425	19796	19162	18519	17189	15758	14149	-	-

Performance certified is for installation type B - free inlet, ducted outlet. Performance ratings do not include the effects of appurtenances (accessories). Power rating (BHP) does not include transmission losses.

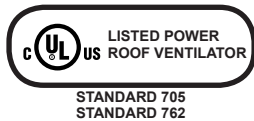

S&P USA Ventilation Systems, LLC., Div. of Soler & Palau Ventilation Group, certifies that the Models CM shown herein are licensed to bear the AMCA Seal (except CM 10). The ratings shown are based on test and procedures performed in accordance with AMCA Publication 211 and AMCA Publication 311 and comply with the requirement of the AMCA Certified Ratings Program.

Ship Schedules:
▲ 3 Day Shipment From Stock
◆ 10 Day Shipment

**How to order:**

	Model Number	Motor HP	RPM	Phase	UL	Stock
<b>Example:</b>	<b>CM24</b>	<b>P</b>	<b>H</b>	<b>1</b>	<b>U</b>	<b>S</b>
	CM24	P=1/3 Q=1/2 R=3/4 S=1 T=1 1/2 V=2 W=3 X=5 Y=7 1/2 Z=10	L=Low M=Medium H=High	1 or 3	U=cULus705 R=cULus762	S=Stock

Indicates Customer Provided Information

# Sound Characteristics

	RPM	Sound Performance Sones / LwA (Inches w.g.)										
		0.5	1	1.5	2	2.5	3	3.5	4	4.5	5	
CM 10	1500	5.7 / 64.2	-	-	-	-	-	-	-	-	-	-
	1875	9.5 / 72.1	8.2 / 69.5	-	-	-	-	-	-	-	-	-
	2250	14.4 / 78.7	12.2 / 76.0	11.4 / 74.6	11.1 / 73.2	-	-	-	-	-	-	-
	2625	19.1 / 83.5	17.1 / 81.5	15.7 / 80.0	15.0 / 79.1	14.6 / 78.1	-	-	-	-	-	-
CM 12	1450	10.2 / 73.3	8.8 / 70.4	-	-	-	-	-	-	-	-	-
	1850	17.6 / 81.9	14.8 / 79.2	13.7 / 77.5	13.1 / 76.3	-	-	-	-	-	-	-
	2275	25 / 88.0	24 / 86.8	21 / 85	20 / 84	19.6 / 83.1	19.3 / 82.4	-	-	-	-	-
	2700	34 / 92.8	34 / 92.6	31 / 91.3	29 / 90.0	28 / 89.3	27 / 88.6	26 / 87.9	26 / 87.5	26 / 87.2	-	-
CM 14	1100	7.7 / 68.7	-	-	-	-	-	-	-	-	-	-
	1500	14.4 / 79.0	12.5 / 76.8	11.3 / 74.8	-	-	-	-	-	-	-	-
	1900	23 / 86.3	21 / 85.1	19.3 / 83.9	18.0 / 82.8	17.0 / 81.7	15.5 / 79.4	-	-	-	-	-
	2300	32 / 92.2	30 / 91.3	29 / 90.6	28 / 90.1	26 / 89.4	25 / 88.8	25 / 88.4	23 / 87.5	-	-	-
	2700	41 / 96.2	40 / 95.6	38 / 95.0	37 / 94.5	36 / 94.1	34 / 93.6	33 / 93.1	32 / 92.6	31 / 92.2	31 / 91.8	-
CM 16	1150	11.6 / 75.3	9.4 / 71.6	-	-	-	-	-	-	-	-	-
	1450	19.3 / 83.5	16.1 / 80.7	14.2 / 78.5	12.4 / 75.9	-	-	-	-	-	-	-
	1800	29 / 90.1	27 / 88.9	24 / 87.1	22 / 85.5	20 / 84.4	18.5 / 82.6	-	-	-	-	-
	2150	39 / 95.1	39 / 94.8	35 / 93.5	32 / 92.2	30 / 91.1	28 / 90.1	27 / 89.4	26 / 88.4	24 / 86.8	23 / 85.5	-
CM 18	1025	12.3 / 75.4	9.5 / 71.5	-	-	-	-	-	-	-	-	-
	1350	23 / 85.2	19.9 / 83.2	16.9 / 80.7	14.6 / 78	14.4 / 76.9	-	-	-	-	-	-
	1650	31 / 90.4	29 / 89.6	26 / 88.1	24 / 86.5	21 / 84.8	19.4 / 83	18.4 / 81.4	-	-	-	-
	2000	42 / 95.8	40 / 95.4	39 / 94.7	36 / 93.7	34 / 92.7	32 / 91.6	30 / 90.5	28 / 89.2	26 / 88.0	25 / 86.7	-
CM 20	775	8.4 / 69.7	-	-	-	-	-	-	-	-	-	-
	1050	17.3 / 81	13.9 / 77.7	12.2 / 74.8	-	-	-	-	-	-	-	-
	1300	27 / 88.4	24 / 86.3	21 / 84.4	19.7 / 82.9	18.0 / 81	-	-	-	-	-	-
	1550	37 / 93.2	34 / 92.2	31 / 90.6	28 / 89.2	27 / 88.1	25 / 87.1	24 / 85.7	22 / 84.1	-	-	-
	1825	47 / 97.5	45 / 96.9	43 / 96.0	39 / 94.9	36 / 93.7	35 / 92.9	33 / 92.2	32 / 91.3	31 / 90.5	29 / 89.3	-
CM 22	575	5.7 / 62.7	-	-	-	-	-	-	-	-	-	-
	825	13.1 / 76.4	10.6 / 72.9	-	-	-	-	-	-	-	-	-
	1225	30 / 89.7	27 / 88.2	24 / 86.4	22 / 84.9	21 / 83.3	19.8 / 82.1	-	-	-	-	-
	1600	46 / 96.9	45 / 96.7	42 / 95.8	40 / 94.7	37 / 93.7	35 / 92.8	33 / 91.9	32 / 91.0	31 / 90.2	30 / 89.4	-
CM 24	500	5.2 / 61.9	-	-	-	-	-	-	-	-	-	-
	825	17.6 / 81.4	14.3 / 78.4	12.1 / 75.2	-	-	-	-	-	-	-	-
	1175	34 / 92.1	32 / 91.4	29 / 90.1	26 / 88.5	24 / 86.8	23 / 85.5	20 / 83.2	-	-	-	-
	1500	50 / 98.6	50 / 98.3	48 / 97.9	45 / 97.1	42 / 96.4	40 / 95.4	37 / 94.4	35 / 93.3	34 / 92.5	33 / 91.7	-
CM 27	450	5.6 / 62.1	-	-	-	-	-	-	-	-	-	-
	750	18.9 / 82.5	15.6 / 79.4	12.9 / 75.9	-	-	-	-	-	-	-	-
	1025	32 / 91.6	31 / 91.0	28 / 89.5	25 / 87.9	23 / 86.0	21 / 83.9	19.8 / 82.5	-	-	-	-
	1300	48 / 98.2	47 / 98.0	47 / 97.7	44 / 96.9	41 / 96.0	39 / 95.0	36 / 93.9	34 / 92.7	31 / 91.3	30 / 90.1	-
CM 30	400	5.6 / 62.2	-	-	-	-	-	-	-	-	-	-
	550	12.7 / 75.7	9.5 / 70.8	-	-	-	-	-	-	-	-	-
	775	26 / 87.5	22 / 85.3	19.4 / 82.8	17.2 / 80.5	16.3 / 78.9	-	-	-	-	-	-
	1025	43 / 96.0	41 / 95.1	38 / 93.9	34 / 92.6	32 / 91.1	29 / 89.7	28 / 88.4	27 / 87.4	27 / 87.4	-	-
CM 36	425	9.1 / 69.9	-	-	-	-	-	-	-	-	-	-
	575	19.8 / 82.1	16.0 / 78.3	13.1 / 75.0	-	-	-	-	-	-	-	-
	725	32 / 89.8	28 / 87.7	25 / 85.5	22 / 83.5	20.0 / 81.3	-	-	-	-	-	-
	875	43 / 95.2	40 / 94.2	37 / 92.5	33 / 90.9	31 / 89.7	29 / 88.2	26 / 86.6	26 / 85.4	-	-	-

The A-weighted sound ratings shown have been calculated per AMCA standard 301. Values shown are for inlet Lw(A) sound power levels for installation type B - free inlet, ducted outlet. Ratings do not include the effect of duct end corrections.



S&P USA Ventilation Systems, LLC, Div. of Soler & Palau Ventilation Group, certifies that the Models CM shown herein are licensed to bear the AMCA Seal (except CM 10). The ratings shown are based on test and procedures performed in accordance with AMCA Publication 211 and AMCA Publication 311 and comply with the requirement of the AMCA Certified Ratings Program.

**Please refer to the General Catalog or contact the Factory for our Full Line of products available on standard shipping schedules.**

# MODEL RCXII/RCXII-SF

## GRAVITY RELIEF/INTAKE

### VENTILATOR

RCXII-SF = SELF FLASHING



**RCXII**  
(sizes 6-20)

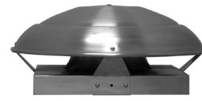

**RCXII**  
(sizes 24-36)



**RCXII-SF**  
(sizes 6-20)

### APPLICATION

Relief and intake ventilators are used to exhaust (relief) or supply (intake) air from or to an enclosed area without the need for a power operated fan. They rely on a difference in static pressure inside and outside the area to create an air flow through the ventilator from the area of higher pressure to the area of lower pressure. If the enclosed area is under a negative pressure, air will flow into the enclosed area (intake). If the enclosed area has a positive pressure, air will flow from it to the outside (relief).

These units can also operate as gravity ventilators, allowing air to flow from an enclosed area using the "Stack Effect". The amount of air flow will depend on the temperature difference inside and outside the area and the height difference between the ventilator and the outside air intake to the area.

### CONSTRUCTION - RCXII

- Low contour spun aluminum hood for attractive appearance.
- All heavy-gauge aluminum construction.
- Weather resistant design for long life and maintenance free operation.
- Aluminum Birdscreen is standard
- One piece curb with spun inlet for maximum efficiency.
- Shipped completely assembled for ease in installation.

### CONSTRUCTION - RCXII-SF

- Low contour spun aluminum hood for attractive appearance.
- All heavy-gauge aluminum construction.
- Weather resistant design for long life and maintenance free operation.
- Galvanized bird screen is standard.
- Shipped completely assembled for ease in installation.

### DIMENSIONAL DATA

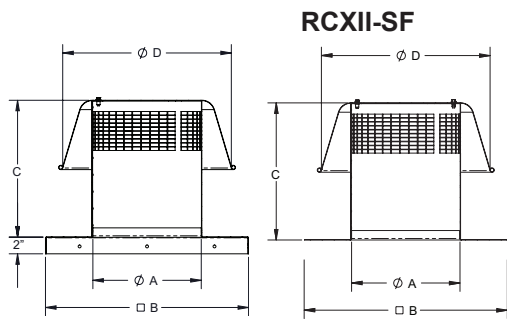

Size	A	B (RCXII)	C (RCXII)	D (RCXII)	B (SF)	C (SF)	D (SF)	Avg. Ship Wt. (lbs.)
06	7	16.5	8	18	18	10	14	7
08	9	16.5	10	18	18	12	14	12
10	11	24	10	25	24	14	20	12
12	13	24	10	25	24	16	20	12
14	15	24	12	32	28	18	27	15
16	17	24	14	32	28	20	27	20
18	19	29.5	14	32	28	22	27	30
20	21	29.5	16	36	32	22	30	30

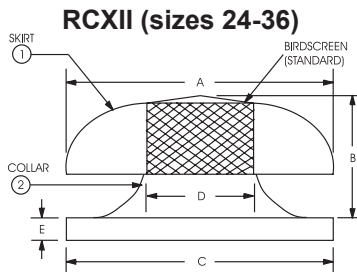

Size	Neck Area sq. ft.	A	B	C	D	E	Avg. Ship Wt. (lbs.)
24	3.30	43-3/4	15-1/4	35-1/2	24-5/8	2	40
26	3.69	43-3/4	16-1/4	35-1/2	26	2	40
30	5.16	43-3/4	18-1/4	42-1/2	30-3/4	2	45
33	5.94	54-3/4	21-1/2	42-1/2	33	2	75
36	7.06	54-3/4	21-1/2	42-1/2	36	2	90

### ACCESSORIES

MODEL RCXII	12" HIGH ROOF CURB		115V MOTORIZED DAMPER		AUTOMATIC GRAVITY DAMPER	
	OD	STOCK NO.	OD	STOCK NO.	OD	STOCK NO.
6-8	14 3/4	611214 ●	8	2401.M0808 ●	8	2401.0808 ●
10-16	22 1/4	611222 ●	15	2401.M1515 ●	15	2401.1515 ●
18-20	27 1/4	611227 ●	21	2401.M2121 ●	21	2401.2121 ●
24-26	33 3/4	611233 ▲	27	2401.M2727 ▲	27	2401.2727 ▲
30-33-36	40 3/4	611240 ▲	34	2401.M3434 ▲	34	2401.3434 ▲

Ship Schedules:
● Next Day Shipment From Stock
▲ 3 Day Shipment From Stock
◆ 10 Day Shipment

Dampers and motor kits ship separate - for field assembly.

**CAUTION:** Motors are not suitable for explosive or flammable environments

ALL DIMENSIONS IN INCHES, WEIGHTS IN POUNDS. OD IS OUTSIDE DIMENSION OF SQUARE CURB AND DAMPER. DUE TO CONTINUING RESEARCH, S&P RESERVES THE RIGHT TO CHANGE SPECIFICATIONS WITHOUT NOTICE.

Please refer to the General Catalog or contact the Factory for our Full Line of products available on standard shipping schedules.

## Models RCXII (sizes 6-20) and Models RCXII-SF

<b>MODEL RCXII Gravity Relief Ventilator</b>												
MODEL	THROAT AREA FT. <sup>2</sup>	CFM Static Pressure									STOCK NO. RCXII	STOCK NO. RCXII-SF
		.025	.050	.100	.125	.150	.200	.250	.300	.350		
6	0.3	93	131	185	207	227	262	293	320	346	RCXII06S ●	RCXII06SFS ●
8	0.4	221	313	442	494	541	625	699	766	827	RCXII08S ●	RCXII08SFS ●
10	0.7	297	420	594	664	727	840	939	1029	1111	RCXII10S ●	RCXII10SFS ●
12	0.9	493	697	986	1102	1208	1394	1559	1708	1845	RCXII12S ●	RCXII12SFS ●
14	1.2	604	853	1207	1349	1478	1707	1908	2091	2258	RCXII14S ●	RCXII14SFS ●
16	1.6	746	1055	1492	1668	1827	2110	2359	2584	2791	RCXII16S ●	RCXII16SFS ●
18	2.0	919	1300	1838	2055	2251	2599	2906	3184	3439	RCXII18S ●	RCXII18SFS ●
20	2.4	1127	1593	2253	2519	2759	3186	3562	3902	4215	RCXII20S ●	RCXII20SFS ●

<b>MODEL RCXII Gravity Intake Ventilator</b>												
MODEL	THROAT AREA FT. <sup>2</sup>	CFM Static Pressure									STOCK NO. RCXII	STOCK NO. RCXII-SF
		.025	.050	.100	.125	.150	.200	.250	.300	.350		
6	0.3	64	91	128	143	157	181	202	222	239	RCXII06S ●	RCXII06SFS ●
8	0.4	148	209	296	331	363	419	468	513	554	RCXII08S ●	RCXII08SFS ●
10	0.7	202	286	404	452	495	571	639	700	756	RCXII10S ●	RCXII10SFS ●
12	0.9	330.5	467	661	739	810	935	1045	1145	1237	RCXII12S ●	RCXII12SFS ●
14	1.2	440.5	623	881	985	1079	1246	1393	1526	1648	RCXII14S ●	RCXII14SFS ●
16	1.6	552	781	1104	1234	1352	1561	1746	1912	2065	RCXII16S ●	RCXII16SFS ●
18	2.0	707.5	1001	1415	1582	1733	2001	2237	2451	2647	RCXII18S ●	RCXII18SFS ●
20	2.4	856	1211	1712	1914	2097	2421	2707	2965	3203	RCXII20S ●	RCXII20SFS ●

Insect Screens - Add .10 to area shown in table.  
 Damper - Add .10 to area shown in table.

## Model RCXII (sizes 24-36)

<b>MODEL RCXII Gravity Relief Ventilator</b>											
MODEL	THROAT AREA FT. <sup>2</sup>	CFM Static Pressure								STOCK NO. RCXII	
		.03	.06	.09	.125	.150	.20	.25	.30		
24	3.30	1535	2168	2656	3128	3429	3960	4425	4851	RCXII24S ▲	
26	3.69	1716	2424	2970	3498	3834	4428	4948	5424	RCXII26S ▲	
30	5.16	2399	3390	4154	4892	5361	6192	6920	7585	RCXII30S ▲	
33	5.94	2762	3903	4782	5631	6172	7128	7966	8732	RCXII33S ▲	
36	7.06	3283	4638	5683	6693	7335	8472	9467	10378	RCXII36S ▲	

<b>MODEL RCXII Gravity Intake Ventilator</b>											
MODEL	THROAT AREA FT. <sup>2</sup>	CFM Static Pressure								STOCK NO. RCXII	
		.03	.06	.09	.125	.150	.20	.25	.30		
24	3.30	1376	1944	2383	2808	3076	3551	3969	4346	RCXII24S ▲	
26	3.69	1539	2173	2664	3140	3439	3970	4439	4860	RCXII26S ▲	
30	5.16	2152	3039	3726	4391	4809	5552	6207	6796	RCXII30S ▲	
33	5.94	2476	3499	4289	5055	5536	6391	7146	7823	RCXII33S ▲	
36	7.06	2944	4158	5097	6008	6580	7597	8493	9298	RCXII36S ▲	

Shaded selections are over recommended 650 FPM. Pick next larger size or use optional weather screen.  
 Insect Screens - Add .10 to area shown in table.  
 Damper - Add .10 to area shown in table.



# MODEL AF/FF/FFC

## CEILING AND INLINE/CABINET VENTILATORS

### APPLICATION

The extremely quiet AF, FF, and FFC ventilators are used to exhaust air from a variety of commercial and institutional applications, such as restrooms, conference rooms, offices, storage areas, restaurants, retail stores, schools, and similar buildings...anywhere quiet, high-capacity ventilation is needed.

The forward curved centrifugal wheel with its high static pressure capability makes these ventilators suitable for either ducted or nonducted applications. They include removable blower assemblies and plug-in permanently lubricated motors for ease of servicing and cleaning.

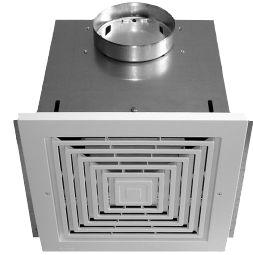

S&P USA Ventilation Systems, LLC., Div. of Soler & Palau Ventilation Group, certifies that the Models AF/FF/FFC shown herein are licensed to bear the AMCA Seal. The ratings shown are based on test and procedures performed in accordance with AMCA Publication 211 and AMCA Publication 311 and comply with the requirement of the AMCA Certified Ratings Program.

<b>MODEL FF</b>		<b>Ceiling Ventilator</b>											<b>Ventilator with Motor, Grille &amp; Backdraft Damper</b>	
MODEL FF	AMPS @ 60HZ/ WATTS	RPM @ 1/8	<b>CFM / Sones at Static Pressure</b>										Average Ship Wt. Lbs	120/1/60 STOCK NO.
			0	1/10	1/8	1/4	3/8	1/2	5/8	3/4	7/8	1		
50	0.8/48	1870	52	49	47	42	29	-	-	-	-	-	4	FF50 ●
			3.9	4.3	4.4	4.6	5.5	-	-	-	-	-		
100	1.1/87	640	136	115	109	93	80	65	44	12	-	-	23	FF100 ●
			0.5	0.8	0.9	1.3	1.8	2.3	3.0	3.2	-	-		
150	1.3/100	710	181	161	157	141	132	124	114	94	62	-	FF150 ●	
			1.3	1.4	1.5	2.2	2.6	3.1	3.6	4.1	4.6	-		
200	1.8/127	740	231	214	210	196	186	177	165	144	113	51	FF200 ●	
			1.6	1.8	1.7	2.3	2.9	3.5	4.1	4.9	5.3	5.3		
250	2.1/166	830	272	261	259	250	242	233	218	201	165	99	FF250 ●	
			2.1	2.3	2.2	2.9	3.3	3.9	4.4	4.8	5.5	5.8		
300	2.6/212	905	312	309	308	303	296	287	273	254	219	125	FF300 ●	
			2.8	2.9	2.9	3.3	3.5	3.9	4.3	4.7	5.1	5.6		
400	1.4/146	735	480	442	434	388	344	299	229	182	114	33	FF400 ●	
			2.0	2.4	2.3	2.8	3.3	3.8	4.5	4.8	5.4	5.6		
500	2.2/232	810	538	520	514	491	463	434	389	339	282	186	34	FF500 ●
			3.0	3.1	3.3	3.6	4.0	4.4	5.0	5.7	6.2	6.7		
700	2.9/313	960	722	704	701	667	640	607	571	534	453	333	FF700 ●	
			4.5	4.6	4.7	4.8	5.0	5.2	5.6	6.2	7.1	7.2		
900	3.0/306	650	918	905	901	877	842	793	725	636	536	390	64	FF900 ●
			3.8	4.0	4.1	4.0	4.2	4.3	4.4	4.9	4.5	5.3		
1500	5.0/468	955	1578	1526	1513	1438	1371	1285	1198	1103	1000	816	FF1500 ●	
			8.6	8.4	8.4	8.1	7.5	7.0	6.7	6.2	5.8	5.8		

Performance ratings include the effects of inlet grille and backdraft damper in the airstream. Speed (RPM) shown is nominal. Performance is based on actual speed of test. The sound ratings shown are loudness values in fan sones at 5' (1.5m) in a hemispherical free field calculated per AMCA Standard 301. Values shown are for installation Type B: free inlet fan sone levels. Performance certified is for installation Type B: Free inlet, Ducted outlet.

Ship Schedules:
● Next Day Shipment From Stock

<b>Model AF80 Ceiling Ventilator</b>		<b>Ventilator with Motor, Grille &amp; Backdraft Damper</b>											
AMPS @ 60HZ/ WATTS	<b>CFM / Sones at Static Pressure (in wc)</b>								Volts	Nominal (RPM)	Duct Size	Average Ship Wt. (lbs)	STOCK NO.
	0.0	0.1	0.15	0.2	0.25	0.3	0.35	0.4					
0.3/27	89	79	72	65	58	51	44	36	120	1,110	4" Round	8	AF80 ●
	0.6	0.9	-	-	2.1	-	-	-					

Performance ratings include the effects of inlet grille and backdraft damper in the airstream. Speed (RPM) shown is nominal. Performance is based on actual speed of test. The sound ratings shown are loudness values in fan sones at 5' (1.5m) in a hemispherical free field calculated per AMCA Standard 301. Values shown are for installation Type B: free inlet fan sone levels. Performance certified is for installation Type B: Free inlet, Ducted outlet.

DUE TO CONTINUING RESEARCH, S&P RESERVES THE RIGHT TO CHANGE SPECIFICATIONS WITHOUT NOTICE.

Please refer to the General Catalog or contact the Factory for our Full Line of products available on standard shipping schedules.

# MODEL FF/FFC cont'd

## CONSTRUCTION

### Housing

- Rugged, 20 gauge galvanized steel.
- Duct connector.
- 1/2" acoustic insulation inside (except FF50, & FFC's).
- Integral automatic backdraft damper.
- Easy inline conversion available (FF100-FF1500).
- Mounting brackets for easy installation and adaptability to numerous mounting requirements.
- Factory shipped in horizontal discharge position easily converted to vertical discharge.
- FFC inline units have a removable panel which allows for easy motor access without disturbing duct work.

### Blower

- Low RPM for quiet operation, speed controllable.
- Resilient anti-vibration mounts (FF50 & AF80 rigid mount).
- Balanced, polymeric, centrifugal blower wheel for quiet, efficient performance. (Metal wheel on FFC2000 & FFC3500).
- Permanently lubricated, thermally protected motor.
- Plug in motor designed for continuous operation.

## Grille

- Conceals interior.
- Low profile styling, blends with any decor.
- White polymeric (FF50 - FF300).
- Metal finished with white enamel (FF400 - FF1500).

## ACCESSORIES

- Complete selection available, see pages 70-71.



S&P USA Ventilation Systems, LLC., Div. of Soler & Palau Ventilation Group, certifies that the Models FF/FFC shown herein are licensed to bear the AMCA Seal. The ratings shown are based on test and procedures performed in accordance with AMCA Publication 211 and AMCA Publication 311 and comply with the requirement of the AMCA Certified Ratings Program.

<b>MODEL FFC</b>		<b>Inline/Cabinet Ventilators</b>											<b>Ventilator with Motor and Duct Connectors</b>						
MODEL FFC	AMPS @ 60HZ/ WATTS	RPM @ 1/8	<b>CFM / Sones at Static Pressure</b>										Average Ship Wt. Lbs.	120/1/60 STOCK NO.					
			0	1/10	1/8	1/4	3/8	1/2	5/8	3/4	7/8	1							
100	1.0/87	760	121	108	106	97	93	86	70	44	17	-	23	FFC100 ●					
			0.5	0.7	0.7	1.1	1.4	1.8	2.1	2.4	2.6	-							
150	1.3/100	920	153	148	147	140	134	125	111	91	54	18		34	FFC150 ●				
			0.9	1.0	1.1	1.4	1.6	1.9	2.1	2.2	2.4	2.6							
200	1.8/127	865	205	196	195	190	185	175	158	135	96	47			64	FFC200 ●			
			1.7	1.9	1.9	2.1	2.3	2.4	3.0	3.3	3.4	3.4							
250	2.1/166	1005	248	245	245	241	235	224	208	183	141	84				64	FFC250 ●		
			2.0	2.3	2.3	2.8	2.8	3.2	3.4	3.6	3.9	3.8							
300	2.6/212	1145	300	294	293	285	274	259	243	214	168	113					64	FFC300 ●	
			2.9	3.0	3.1	3.3	3.4	3.5	3.6	3.7	4.0	3.9							
400	1.4/146	775	450	415	406	360	313	271	223	167	90	6.0						64	FFC400 ●
			1.4	1.6	1.6	1.9	2.2	2.6	2.9	3.4	3.6	3.9							
500	2.2/232	890	546	526	519	496	472	447	407	364	306	232	64						FFC500 ●
			2.4	2.4	3.4	3.7	3.9	3.8	3.9	4.0	4.3	4.3							
700	2.9/313	1090	704	686	681	656	631	604	575	533	480	412		64					FFC700 ●
			3.6	3.8	3.7	3.9	4.0	4.2	4.3	4.4	4.7	5.0							
900	3.0/306	810	930	902	894	853	807	754	685	587	442	300			64				FFC900 ●
			3.7	3.8	3.8	3.8	3.7	3.8	3.9	4.0	4.0	4.1							
1500	5.0/468	1055	1275	1228	1214	1152	1092	1029	958	871	764	631				64			FFC1500 ●
			6.8	6.8	6.7	6.5	6.3	6.0	6.0	6.0	6.0	6.1							

Performance ratings include the effects of backdraft damper in the airstream. Speed (RPM) shown is nominal. Performances based on actual speed of test. The sound ratings shown are loudness values in fan sones at 5' (1.5m) in a hemispherical free field calculated per AMCA Std. 301. Values shown are for installation Type D: Ducted inlet, Ducted outlet. Ratings do not include the effect of duct end correction. Performance ratings include the effects of 18 feet of round inlet duct and, if ne

<b>MODEL FFC</b>		<b>Inline/Cabinet Ventilators</b>										<b>Ventilator with Motor and Duct Connectors</b>		
MODEL FFC	AMPS @ 60HZ/ WATTS	RPM @ 1/8	<b>CFM / Sones at Static Pressure</b>										Average Ship Wt. Lbs.	120/1/60 STOCK NO.
			0	1/10	1/8	1/4	3/8	1/2	5/8	3/4	7/8	1		
2000	5.8/590	965	1891	1803	1791	1657	1508	1347	1165	808	284	-	92	FFC2000 ●
			10.3	9.8	9.4	9.0	8.6	9.1	8.9	7.0	6.7	-		

Performance ratings do not include the effects of appurtenances in the airstream. Speed (RPM) shown is nominal. Performance is based on actual speed of test. The sound ratings shown are loudness values in fan sones at 5' (1.5m) in a hemispherical free field calculated per AMCA Std. 301. Values shown are for installation Type D: Ducted inlet, Ducted outlet. Ratings do not include the effect of duct end correction. Performance certified is for Installation Type D; Ducted inlet, Ducted outlet.

DUE TO CONTINUING RESEARCH, S&P RESERVES THE RIGHT TO CHANGE SPECIFICATIONS WITHOUT NOTICE.

Please refer to the General Catalog or contact the Factory for our Full Line of products available on standard shipping schedules.

# DIMENSIONAL DATA - CEILING VENTILATOR

FF50

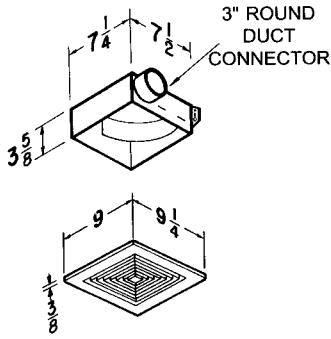

FF200, 250 & 300

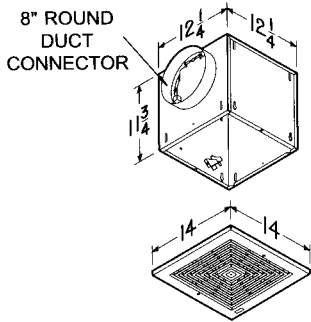

FF80

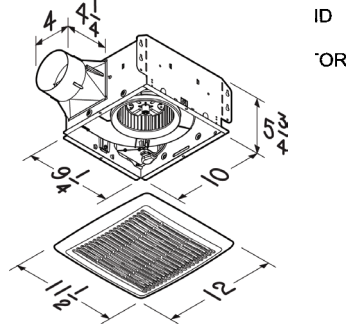

FF400, 500 & 700

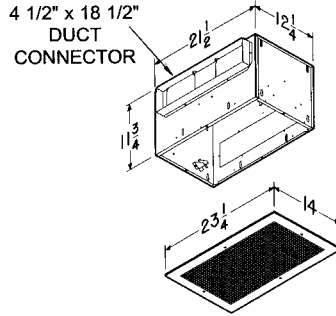

FF100 & 150

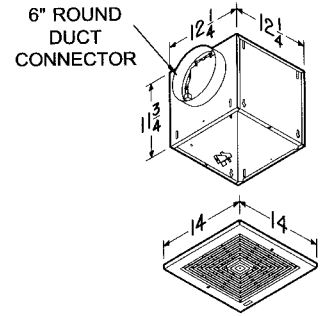

FF900 & 1500

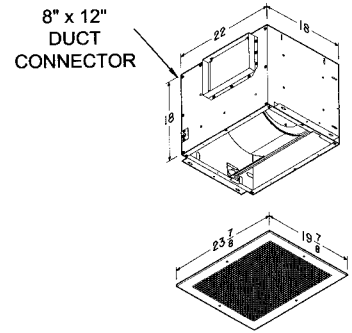

## Inline/Cabinet Ventilator

FFC100 & 150

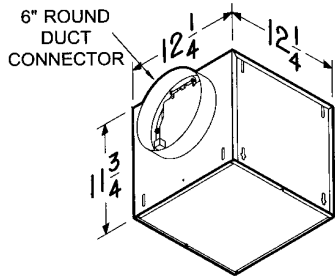

FFC200, 250 & 300

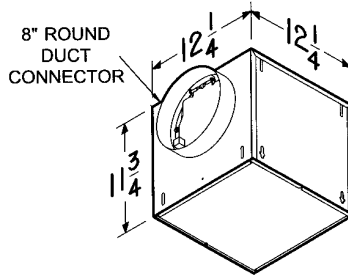

FFC400, 500 & 700

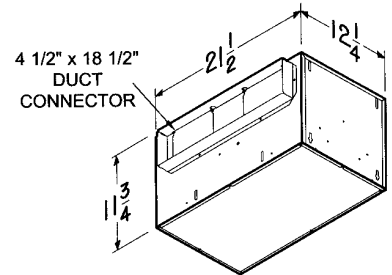

FFC900 & 1500

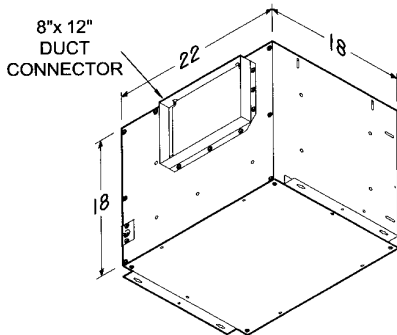

FFC2000

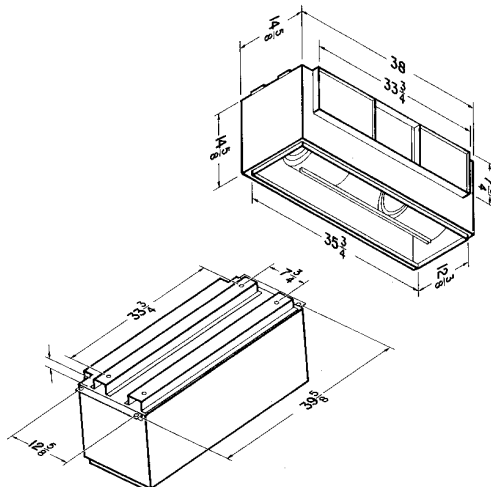

FFC3500

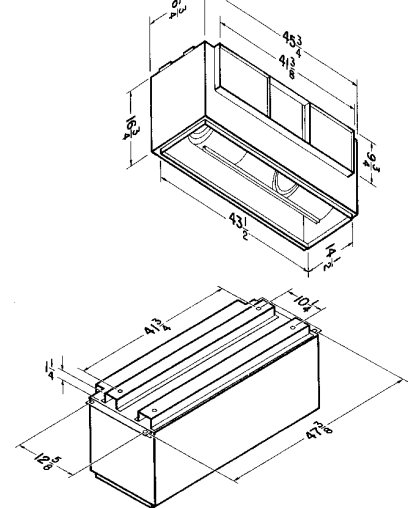

Please refer to the General Catalog or contact the Factory for our Full Line of products available on standard shipping schedules.

# ACCESSORIES

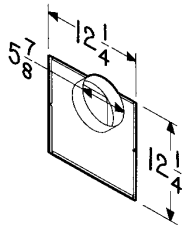

- 961L In-Line Adaptor Kit**
- Galvanized steel
  - Fits FF100 & FF150
  - For 6" round duct intake

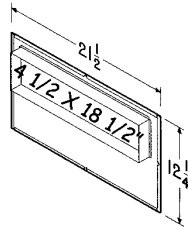

- 982L In-Line Adaptor Kit**
- Galvanized steel
  - Fits FF400, FF500 & FF700
  - 4 1/2 x 18 1/2" duct intake

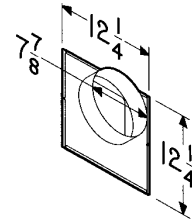

- 981L In-Line Adaptor Kit**
- Galvanized steel
  - Fits FF200, FF250 & FF300
  - For 8" round duct intake

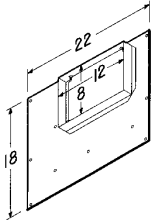

- 983 In-Line Adaptor Kit**
- Galvanized steel
  - Fits FF900 & FF1500
  - 8" x 12" round duct intake

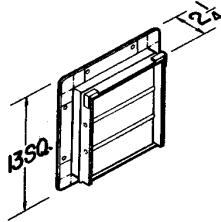

- Model 441 Wall Cap**
- Gravity dampers
  - Collar with birdscreen for attaching 10" round duct
  - Steel construction with aluminum louvers

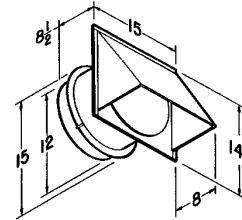

- Model 613 Wall Cap**
- High Capacity
  - Built-in backdraft damper & birdscreen
  - Aluminum natural finish
  - For 12" round duct

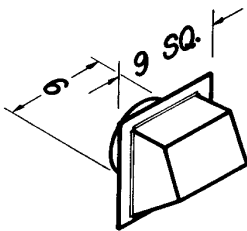

- Model 641 Wall Cap**
- Aluminum natural finish
  - Built-in backdraft damper & birdscreen
  - For 6" round duct

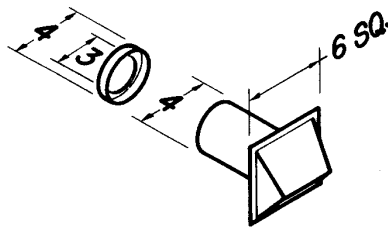

- Model 642 Wall Cap**
- Aluminum natural finish
  - Built-in backdraft damper & birdscreen
  - For 3" or 4" round duct (4" to 3" transition included)

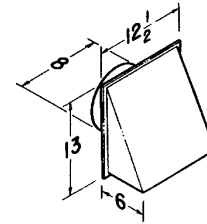

- Model 643 Wall Cap**
- Aluminum natural finish
  - Built-in backdraft damper
  - For 8" round duct

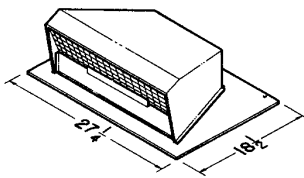

- Model 437 Roof Cap**
- High capacity design - up to 1200 CFM
  - Built-in birdscreen
  - Steel, black electrically - bonded epoxy finish

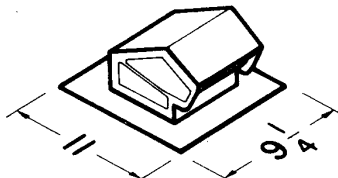

- Model 636 Roof Cap**
- Black electrically - bonded epoxy finish
  - Built-in backdraft damper & birdscreen
  - For 3" or 4" round duct

**Model 636AL - Aluminum**

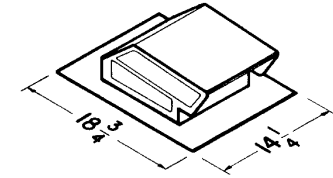

- Model 634 Roof Cap**
- Black electrically - bonded epoxy finish
  - Built-in backdraft damper & birdscreen
  - For 3 1/4" x 10" or up to 8" round duct

**Model 644 - Aluminum**

# ACCESSORIES

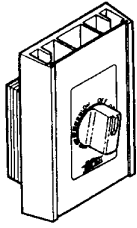

### Speed Control

- Adjust speed from 100 to 50%
- 3 amp, 5 amp & 10 amp - 120V
- 6 amp - 240V

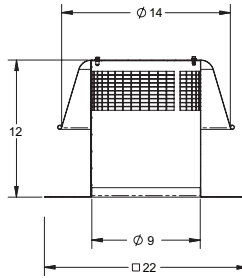

### Model RCXII SF08 Flat Roof Cap

- For flat roof installation
- Spun Aluminum - natural finish
- Built-in birdscreen
- For up to 8" round duct

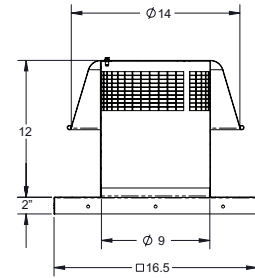

### Model RCXII 08 Curb Mount Roof Cap

- For curb mount installation
- Use 14-3/4" x 14-3/4" x 12" high curb
- Spun Aluminum - natural finish
- Built-in birdscreen
- For up to 8" round duct

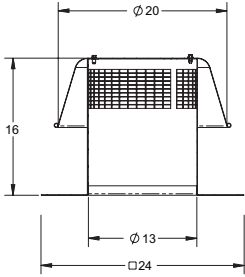

### Model RCXII SF12 Flat Roof Cap

- For flat roof installation
- Spun Aluminum - natural finish
- Built-in birdscreen
- For up to 12" round duct

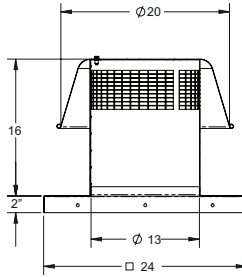

### Model RCXII 12 Curb Mount Roof Cap

- For curb mount installation
- Use 22-1/4" x 22-1/4" x 12" high curb.
- Spun Aluminum - natural finish
- Built-in birdscreen
- For up to 12" round duct

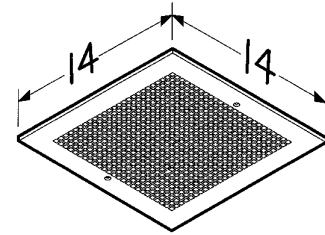

### Model MG 1 Metal Grille Kit

- White enamel painted steel
- Mounting screws included
- Fits FF100, FF150, FF200, FF250 & FF300

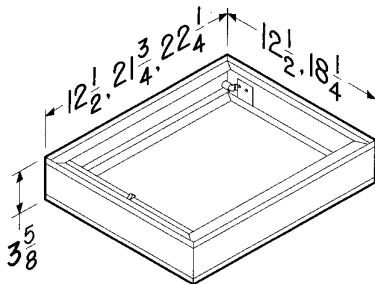

### Models RD1, RD2 & RD3 Radiation Dampers

- UL rated for use in 1, 2 or 3 hour rated floor-ceiling, roof-ceiling design
- Galvanized steel frame
- High temperature, non-asbestos, reinforced fiber thermal fabric
- 212°F fusible link
- Stainless steel negator-type closure spring
- RD1 (12 1/4' x 12 1/4") fits FF100 - FF300
- RD2 (21 1/2" x 18") fits FF400 - FF700
- RD3 (22" x 18") fits FF900 - FF1500

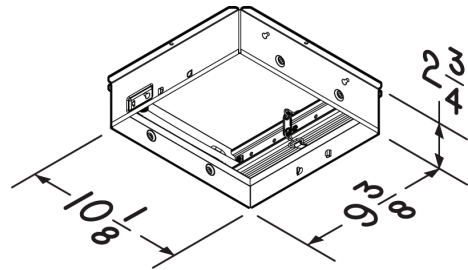

### Model RD80AF Radiation Damper

- UL rated for use in 1, 2 or 3 hour rated floor-ceiling, roof-ceiling design
- Galvanized steel frame
- High temperature, non-asbestos, reinforced fiber thermal fabric
- 165°F fusible link
- Stainless steel closure springs
- RD80AF fits AF80

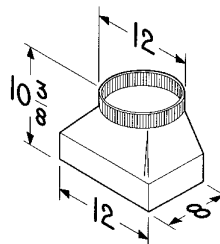
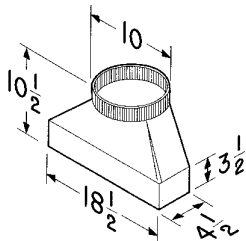

### Models 423 & T81212 Duct Transitions

- Galvanized steel
- Allows for quick transition to easy-to-obtain-and-install round ducting
- 423 (4 1/2" x 18" to 10" round) for use with FF400 thru FF700
- T81212 (8" x 12" to 12" round) for use with FF900 and FF1500

# MODEL FF/FFC

## Optional Accessory Compatibility Chart

### Ceiling & Inline/Cabinet Ventilators

STOCK NO.	CEILING MOUNT MODEL FF							IN-LINE/CABINET MODEL FFC					
VARIABLE SPEED CONTROLS	FF50 AF80	FF100 FF150	FF200 FF250 FF300	FF400 FF500	FF700	FF900	FF1500	FFC100 FFC150	FFC200 FFC250 FFC300	FFC400 FFC500 FFC700	FFC900	FFC1500	FFC2000
2727.1 (5 AMP 120V) ●	X	X	X	X			X	X					
2828.1 (10AMP 120V) ●		X	X	X	X	X	X	X	X	X	X	X	X
<b>ROOF CAPS</b>													
437 ♦				X	X					X			
RCXII08SFS, RCXII08S ●	X	X	X					X	X				
RCXII12SFS, RCXII12S ●				X	X	X	X			X	X	X	X
634 ●		X	X					X	X				
636 ●	X												
RCXII18S ●													X
RCXII20S ●													X
<b>ROOF CURBS FOR RCXII08 &amp; RCXII12</b>													
611214 ●	X	X	X					X	X				
611222 ●				X	X	X	X			X	X	X	X
<b>WALL CAPS</b>													
441 ♦				X	X					X			
613 ♦						X	X				X	X	
641 ●		X						X					
642 ♦													
643 ●			X						X				
<b>IN-LINE ADAPTERS</b>													
961L ♦		X											
981L ♦			X										
982L ♦				X	X								
983L ♦						X	X						
<b>UL RADIATION DAMPERS</b>													
RD1 ♦		X	X										
RD2 ♦				X	X								
RD3 ♦						X	X						
RD for AF80 ♦	X												
<b>METAL Grille KIT</b>													
G102 ♦													X
MG1 ●		X	X										
<b>DUCT TRANSITIONS</b>													
423 ●				X	X					X			
T81212 ●						X	X				X	X	
<b>DAMPER KITS</b>													
D100 ●													X
<b>VIBRATION DAMPENING HANGERS (4)</b>													
v102 ●		X	X	X	X	X	X	X	X	X	X	X	X
<b>HEAVY DUTY</b>													
v104 ●		X	X	X	X	X	X	X	X	X	X	X	X

Ship Schedules:
● Next Day Shipment From Stock
♦ 10 Day Shipment



# ROOF VENTILATOR ACCESSORIES

## PREFABRICATED ROOF CURB

Factory built curbs reduce installation time and assure proper fit of ventilator and curb.

### STANDARD CANTED ROOF CURB FEATURES

- Continuously welded 18 gauge galvanized steel with integral base plate.
- 1 1/2 x 1 1/2 wood nailer.
- 1" semi-rigid insulation.
- Fully mitered 3" cant.
- Damper mounting flange (damper tray).
  - A = Curb OD, see specific ventilators for recommended size.
  - B = Curb height, 12" standard
  - C = Nailer width, 1 1/2" standard.

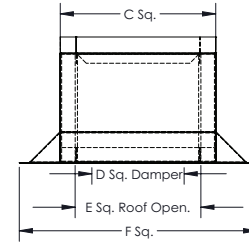
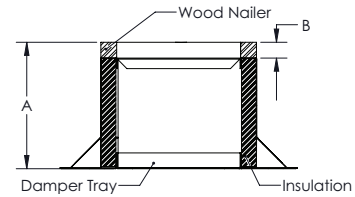
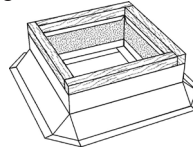

### STANDARD CANTED ROOF CURB

### RESTAURANT ROOF CURB STANDARD FEATURES

- Constructed of 18 ga. galv. steel with continuous welded seams and integral base plate for water tightness and extra strength.
- Wide base flashing to insure adequate bond to roofing surface for water tight seal to roof.
- Insulation not furnished when curb is equipped with special ventilation slots.
- Top of curb covered with 1/4" polystyrene gasket for weather seal and to reduce metal to metal conducted noise.
- Minimum curb height is 18" to comply with NFPA Bulletin 96

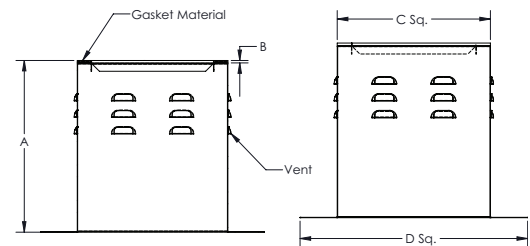
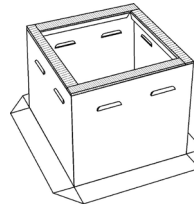

### VENTED RESTAURANT ROOF CURB

## STANDARD DUTY - BOX FRAME BACKDRAFT DAMPER

For exhaust ventilator models **SDB, DB, LPD, STXD, STXB, TXB and ARE.**  
For supply fan - refer to the flanged frame damper on the following page.

- Maximum face velocity - 1000 FPM.
- 19 gauge galvanized steel frame.
- 26 gauge aluminum blades.
- Stainless steel pivots.
- Felt seal between blades.
- Adjustable spring counter balance.
- Max 250°F ambient temp (130°F for motor).

### Notes:

- (1) Units are undersized 1/4" to fit in square ducts or inside the roof curb.
- (2) Do not mount fan less than 1/3 diameter of the fan from the damper.
- (3) Dampers shipped in individual cartons.
- (4) Motor kits ship loose for field installation.

A = Damper OD, see specific ventilator for specific size.

### DO NOT USE A DAMPER IN GREASE REMOVAL APPLICATIONS OR WITH A UL-762 LISTED EXHAUST FAN FOR KITCHEN VENTILATION

**CAUTION: Motor kits are not suitable for use in explosive or flammable areas or airflows.**

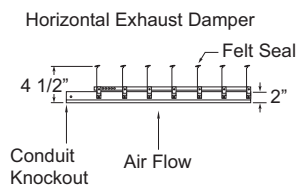
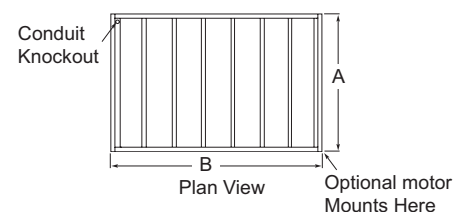
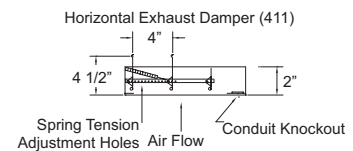
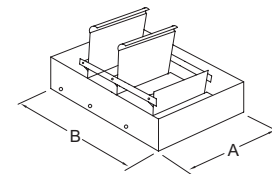

DUE TO CONTINUING RESEARCH, S&P RESERVES THE RIGHT TO CHANGE SPECIFICATIONS WITHOUT NOTICE.

*Please refer to the General Catalog or contact the Factory for our Full Line of products available on standard shipping schedules.*



# ROOF VENTILATOR ACCESSORIES, cont'd.

## HEAVY-DUTY FLANGED FRAME BACKDRAFT DAMPER

For exhaust ventilator models **RCXII**.  
 For supply ventilator models **KSF, ARE and RCXII**.

- Maximum face velocity - 3000 FPM.
- 20 gauge galvanized steel frame.
- .025 aluminum blades.
- 28 gauge galvanized steel blades for 7 1/2 HP ventilator models (XHD).
- Stainless steel axles.
- Galvanized steel tie bars, stainless steel pins.
- Extruded vinyl seals between blades, mechanically locked into blade.
- Spring assist kit supplied with XHD dampers.

- (1) Do not mount fan less than 1/3 diameter of fan from the shutter.
- (2) Motors are 115/208/230V.
- (3) Dampers shipped in individual cartons.
- (4) Motors and counterbalance kits ship separately.
- (5) Units for horizontal mounting with air flow down require counter balance kits (for gravity operation).
- (6) Multiple section assemblies may require bracing to support the weight of the assembly and to hold against system pressure. **BRACING SUPPLIED BY OTHERS.**
- (7) Multiple section dampers are factory joined (except 72" and larger).

**CAUTION: Motor kits are not suitable for use in explosive or flammable areas or airflows.**

A = Damper OD, see specific ventilator for recommended size.  
 B = A + 2 1/2" (OD of damper flange)

**NOTE:** For supply applications with airflow vertically down, a counter balance weight kit is supplied for field installation.

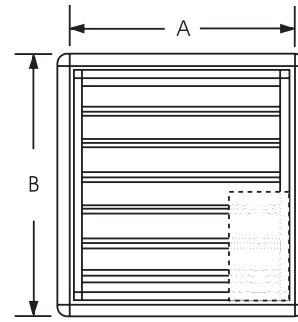

DETAIL #1  
 Single panel damper for ventilator size 36 & smaller.

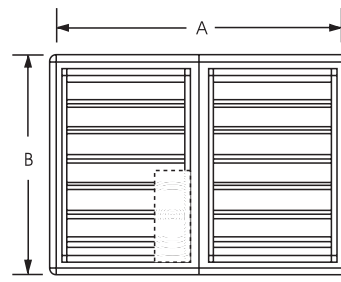

DETAIL #2  
 Two panel damper for ventilator size 42 & larger.



Spring Assist kit supplied with HEAVY DUTY dampers

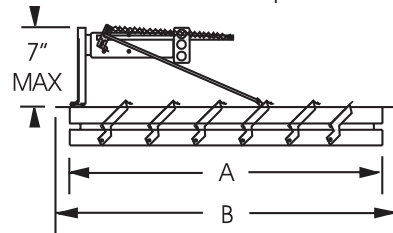

Exhaust

GRAVITY  
  
 AIR FLOW UP  
 MOTORIZED

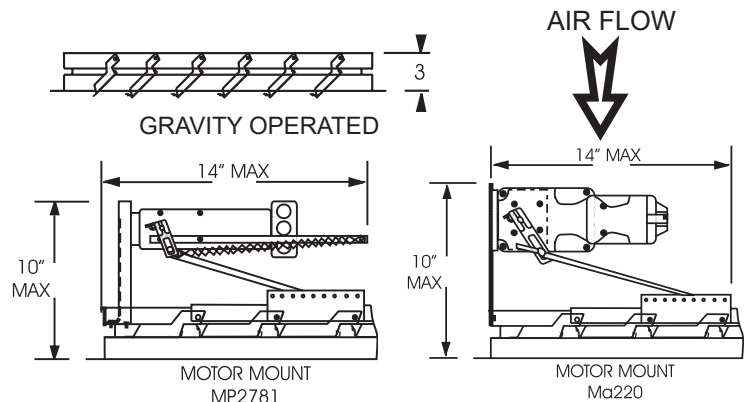

Supply

# SIDEWALL PROPELLER FAN ACCESSORIES

## WALL SHUTTERS/DAMPERS

For fan models **GED, LCE**

- Maximum face velocity - 2500 FPM.
- .062 mill finish 6063T5 or T6 extruded aluminum frame.
- 26 gauge 3105 mill finish aluminum blades.
- Felt seal on leading edge of blade.

### Notes:

- (1) Do not mount fan less than 12 inches from the shutter.
- (2) Motors are 115/208/230V.
- (3) Dampers shipped in individual cartons.
- (4) Motors ship separately.
- (3) Multiple section assemblies may require bracing to support the weight of the assembly and to hold against system pressure.

### BRACING SUPPLIED BY OTHERS.

- (4) Multiple section dampers are factory jointed

**CAUTION: Motor kits are not suitable for use in explosive or flammable areas or airflows.**

A = Shutter size, see specific fan for recommended size.

B = A + 2 1/2" (OD of shutter flange)

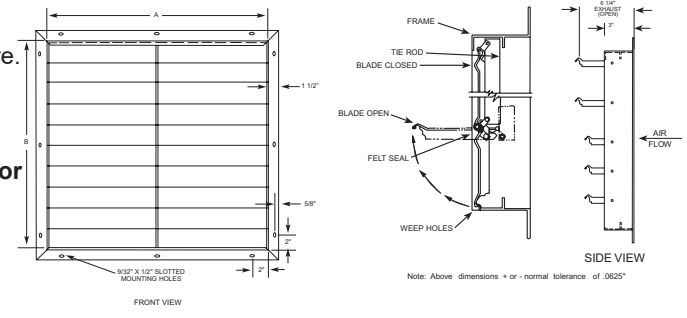
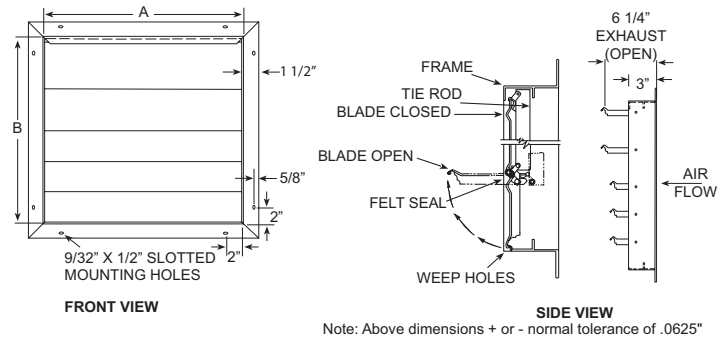

For fan models **LCS**

- Maximum face velocity - 3000 FPM.
- 20 gauge galvanized steel frame.
- .025 aluminum blades.
- Extruded vinyl seals between blades mechanically locked into blade.

### Notes:

- (1) Do not mount fan less than 12 inches from the shutter.
- (2) Motors are 115/208/230V.
- (3) Dampers shipped in individual cartons.
- (4) Motors ship separately.
- (3) Multiple section assemblies may require bracing to support the weight of the assembly and to hold against system pressure.

### BRACING SUPPLIED BY OTHERS.

- (4) Multiple section dampers are factory jointed

**CAUTION: Motor kits are not suitable for use in explosive or flammable areas or airflows.**

A = Shutter size, see specific fan for recommended size.

B = A + 2 1/2" (OD of shutter flange)

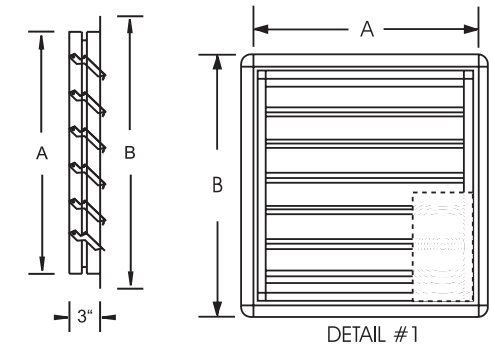

Single panel shutter for fan size 36 & smaller

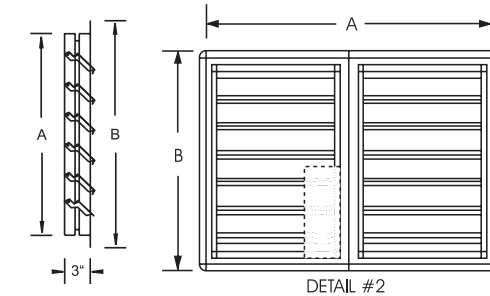

Two panel shutter for fan size 42 & larger

Please refer to the General Catalog or contact the Factory for our Full Line of products available on standard shipping schedules.

# SIDEWALL PROPELLER FAN ACCESSORIES, cont'd

## FAN - WALL HOUSING - SHUTTER - GUARD ASSEMBLY

Factory Assembled Package  
For fan models LC

### APPLICATION

This heavy-gauge, all galvanized G-90 steel housing provides a simple solution to installing a fan and all required accessories in a rough wall opening. It can be used in exhaust or supply applications. Depending on space and maintenance requirements, the wall housing maybe installed inward or outwards of the building. All housings ship with the fan, shutter only on wall packs and guard assembled to lessen jobsite installation costs.

SIZE	A	B	C	D	E	MINIMUM WALL OPENING	EXHAUST	SUPPLY
							RAINHOOD 45 DEG	RAINHOOD 90 DEG.
							F	F
20	25	44	24	22 1/2	20	25 1/2	24 1/4	27 3/4
24	31		30	28 1/2	26	31 1/2	28 1/2	38 1/2
30	37		36	34 1/2	32	37 1/2	34 1/2	44 1/2
36	43		42	40 1/2	38	43 1/2	40 1/2	49
42	49		48	46 1/2	44	49 1/2	44 1/2	56 1/2
48	55		54	52 1/2	50	55 1/2	49 1/2	62 1/2
54	61		60	58 1/2	56	61 1/2	55	73
60	67		66	64 1/2	62	67 1/2	69	73

ALL DIMENSIONS IN INCHES.

Rainhoods, by others are required for all supply applications, and motorized shutters are strongly recommended.

### EXHAUST ARRANGEMENT (TYPICAL)

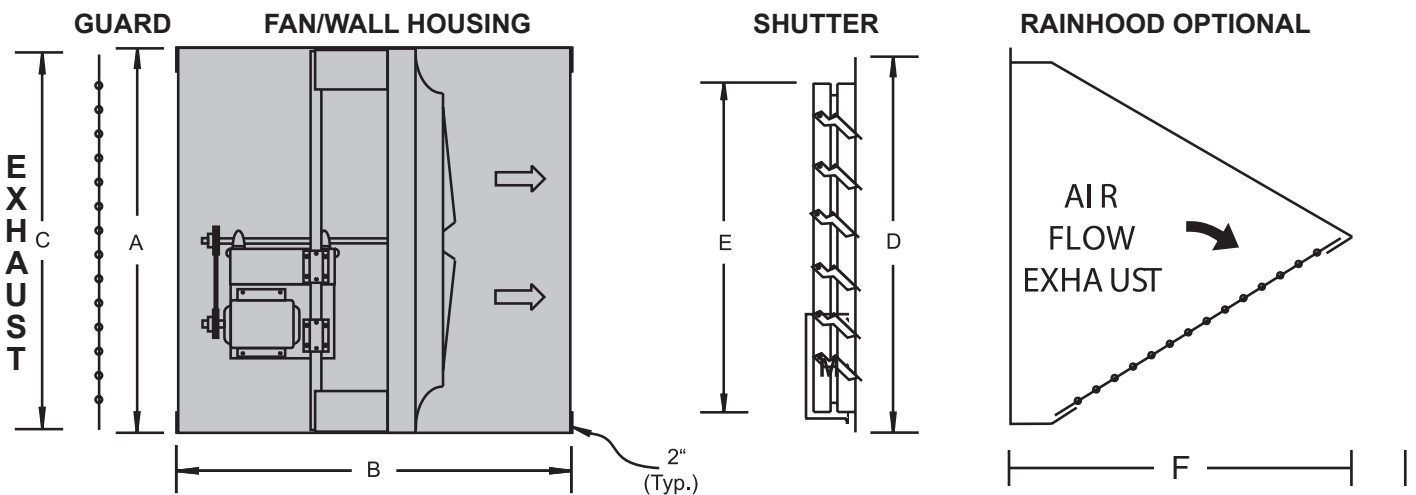

### SUPPLY ARRANGEMENT (TYPICAL)

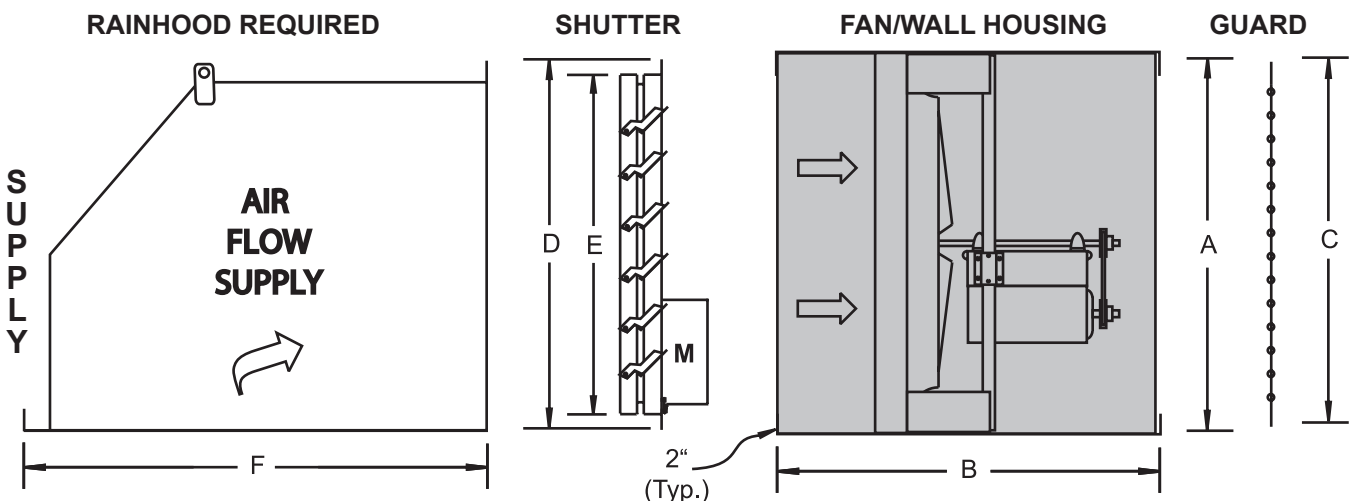

Please refer to the General Catalog or contact the Factory for our Full Line of products available on standard shipping schedules.

# AUTO EXHAUST DAMPER MODEL 411

The Model 411 is a non-flanged horizontal mount exhaust backdraft damper. The frame is galvanized steel with aluminum blades. The blades have a felt seal on the leading edge for quiet closing and better protection from the weather. Spring assisted to allow blades to open quickly. Ideal for use in roof curbs, duct work, or wall collars when using a fan or power roof ventilator. Only available for horizontal mount exhaust applications.



Sizes available – 8" W x 8" H to 30" W x 30" H.

Maximum free area velocity – 2,000 fpm.

## FEATURES

### Frame

- Frame is Galvanized Steel.
- Conduit knockout provided for ease of electrical hook up.
- Easy to motorize. (order 411611 motor pack)
- 2" deep frame.

### Blades

- Blades are 26 gauge Mill Finish Aluminum
- Blades open freely to allow full opening and closing.
- Felt seal on leading edge of blades for quiet closing and better protection from the weather.
- Nylon bushings and stainless steel pivot pins
- Tie rod attached to all blades for simultaneous opening.
- Spring assist to allow blades to open quickly.

### Ratings

- Maximum recommended velocity is 2000 FPM Pressure- 1.0 in w.g - differential pressure
- Temperature -40°F to 180°F

### Options

- Motor packs.

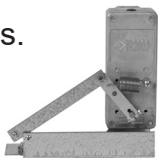

# MODEL 411

## AUTO EXHAUST DAMPER

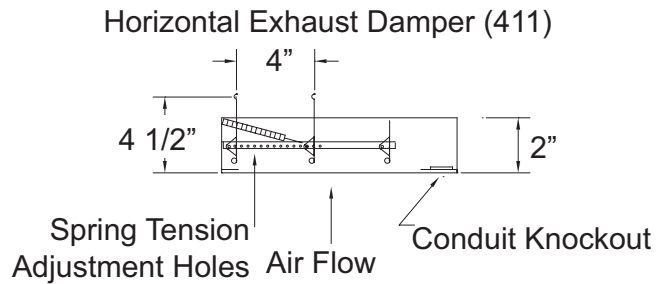
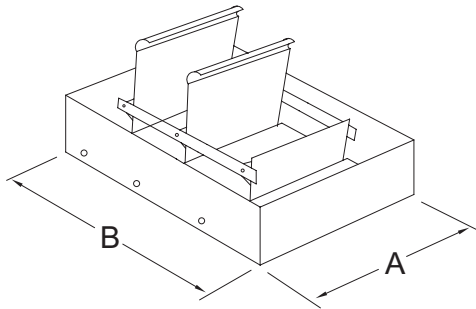

### STANDARD SIZES

#### Dimensions in Inches

Part No.	Overall Frame Dimensions (W x H)	Free Area Dimensions (W x H)	Face Area (Sq. Ft.)	Est. Free Area (Sq. Ft.)	Est. Shipping Weight (lbs)
411008 ●	7.75 x 7.75	6.125 x 7.25	.42	.31	2
411009 ●	8.75 x 8.75	6.50 x 7.25	.53	.33	2.5
411010 ●	9.75 x 9.75	7.125 x 8.25	.66	.41	2.5
411011 ●	10.75 x 10.75	8.50 x 9.25	.80	.55	3
411012 ●	11.75 x 11.75	9.125 x 10.25	.96	.65	3.50
411014 ●	13.75 x 13.75	11.125 x 12.25	1.51	.95	4
411016 ●	15.75 x 15.75	13.125 x 14.25	2.19	1.30	4
411018 ●	17.75 x 17.75	15.125 x 16.25	2.44	1.71	4.5
411019 ●	18.75 x 18.75	16.125 x 17.25	2.71	1.93	4.5
411020 ●	19.75 x 19.75	17.125 x 18.25	3.29	2.17	5
411022 ●	21.75 x 21.75	19.125 x 20.25	3.59	2.69	5
411024 ●	23.75 x 23.75	21.125 x 22.25	3.92	3.26	6
411026 ●	25.75 x 25.75	23.125 x 24.25	4.60	3.89	7
411028 ●	27.75 x 27.75	25.125 x 26.25	5.35	4.58	7.5
411030 ●	29.75 x 29.75	27.125 x 28.25	6.15	5.32	8

**Note:** Dimensions are approximate due to normal tolerances in the manufacturing process. Estimated Free Area calculation is based upon the following formula:  $MD[A+B+(N \times C)]/144$ . Free Area x FPM = CFM; actual performance may vary.

### Optional 411611 Motor Pack Specifications

Motor Pack Part Number	Power Supply Required	Running AMPS	Stall Torque	Lead Length	Installed Unit Dimension		
					H	W	D
411611 ●	115/230V, 60 Hz	.11/.07	77 in. lbs.	6"	8.5	4.5	7.375

Ship Schedules:

- Next Day Shipment From Stock

Please refer to the General Catalog or contact the Factory for our Full Line of products available on standard shipping schedules.

# AUTO EXHAUST DAMPER MODEL 611

The Model 611 is a non-flanged horizontal mount exhaust backdraft damper. The frame is galvanized steel with aluminum blades. The blades have a felt seal on the leading edge for quiet closing and better protection from the weather. Spring assisted to allow blades to open quickly. Ideal for use in roof curbs, duct work, or wall collars when using a fan or power roof ventilator. Only available for horizontal mount exhaust applications.



Sizes available – 34" W x 34" H to 48" W x 48" H.

Maximum free area velocity – 2,250 fpm.

## FEATURES

### Frame

- Frame is Galvanized Steel.
- Conduit knockout provided for ease of electrical hook up.
- Easy to motorize. (order 411611 motor pack)
- 2" deep frame.

### Blades

- Blades are 26 gauge Mill Finish Aluminum with galvanized reinforcement strip.
- Blades open freely to allow full opening and closing.
- Felt seal on leading edge of blades for quiet closing and better protection from the weather.
- Nylon bushings and stainless steel pivot pins
- Tie rod attached to all blades for simultaneous opening.

### Ratings

- Maximum recommended velocity is 2250 FPM Pressure- 1.0 in w.g - differential pressure
- Temperature -40°F to 180°F

### Options

- Motor packs.



# AUTO EXHAUST DAMPER MODEL 611

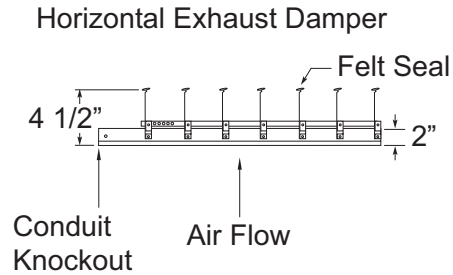
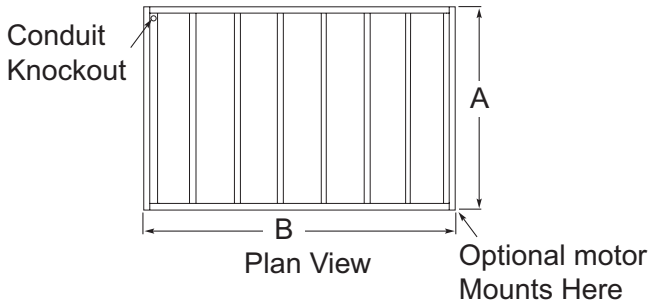

## STANDARD SIZES Dimensions in Inches

Part No.	Overall Frame Dimensions (W x H)	Free Area Dimensions (W x H)	Face Area (Sq. Ft. )	Est. Free Area (Sq. Ft.)	Number of Panels	Est. Shipping Weight (lbs)
611034 ●	33.75 x 33.75	31.125 x 32.25	7.91	6.97	1	15
611035 ●	34.75 x 34.75	31.125 x 33.25	8.39	7.19	1	16
611036 ●	35.75 x 35.75	33.125 x 34.25	8.88	7.88	1	17
611040 ●	39.75 x 39.75	37.125 x 38.25	10.97	9.86	1	19.5
611048 ●	47.75 x 47.75	45.125 x 46.25	15.83	14.49	1	26

**Note:** Dimensions are approximate due to normal tolerances in the manufacturing process. Estimated Free Area calculation is based upon the following formula:  $MD[A+B+(N \times C)]/144$ . Free Area x FPM = CFM; actual performance may vary.

## Optional 411611 Motor Pack Specifications

Motor Pack Part Number	Power Supply Required	Running AMPS	Stall Torque	Lead Length	Installed Unit Dimension		
					H	W	D
411611 ●	115/230V, 60 Hz	.11/.07	77 in. lbs.	6"	8.5	4.5	7.375

Ship Schedules:
● Next Day Shipment From Stock

Please refer to the General Catalog or contact the Factory for our Full Line of products available on standard shipping schedules.



# AUTOMATIC WALL SHUTTER-SINGLE PANEL MODEL 502

The Model 502 is a rear flanged low velocity gravity exhaust shutter. The frame is galvanized steel with mill finish aluminum blades. The blades have a felt seal on the leading edge for quiet closing and better protection from the weather. Ideal for use with direct drive or belt-driven exhaust fans. Recommended for vertical mount exhaust applications only.

Sizes available – 10" W x 10" H to 24" W x 24" H.

Maximum free area velocity – 2,000 fpm.



## FEATURES

### Frame

- 20 gauge galvanized steel.
- Tog-L-Loc and tabbed corners provide rigidity and durability.
- Integrated weather stripping incorporated into frame for additional strength and weather protection.
- Prepunch oblong mounting holes.

### Blades

- 26 gauge 3105 mill finish aluminum.
- Felt seal on leading edge of blade for tight closure and quiet operation.
- Center-mounted galvanized steel tie-rod connects blades for uniform opening and closing.
- 304 stainless steel pivot pins and rivets
- Nylon bushings.

### Ratings

- Maximum recommended velocity is 2,000 FPM
- Temperature - -40 F to 180 F

# AUTOMATIC WALL SHUTTER-SINGLE PANEL MODEL 502

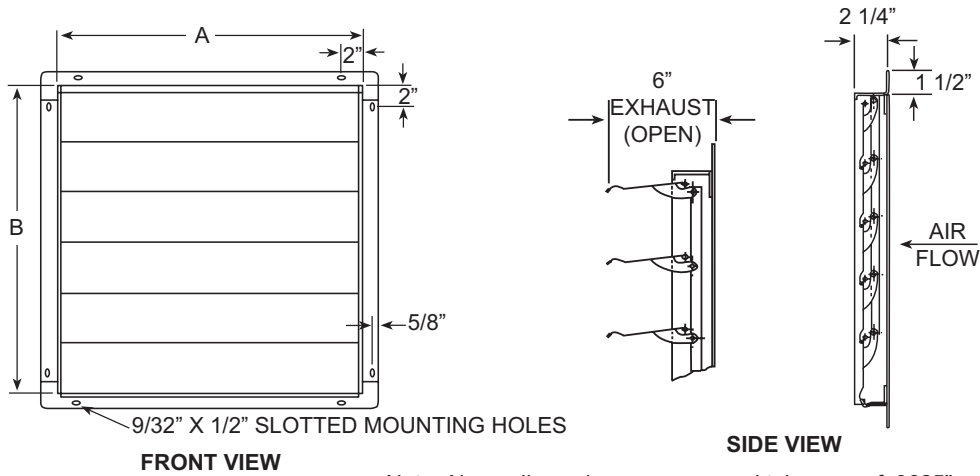

## STANDARD SIZES Dimensions in Inches

Part No.	Panel Size (A x B)	Est. Shipping Weight (lbs)
502010 ●	10 x 10	3.5
502012 ●	12 x 12	4
502016 ●	16 x 16	5.5
502020 ●	20 x 20	7
502024 ●	24 x 24	9.5

Ship Schedules:
● Next Day Shipment From Stock

# AUTOMATIC WALL SHUTTER-SINGLE OR DOUBLE PANEL MODEL 556

The Model 556 is a rear flanged general purpose exhaust shutter. The frame is galvanized steel with mill finish aluminum blades. The blades have a galvanized reinforcement strip across the top of each blade for added strength and counter balancing efficiency. The blades have a felt seal on the leading edge for quiet closing and better protection from the weather. Ideal for use with direct-drive or belt-driven exhaust fans. Recommended for vertical mount exhaust applications only.

Sizes available – 12” W x 12” H to 48” W x 48” H.

Maximum free area velocity – 2,500 fpm.



## FEATURES

### Frame

- .037 gauge galvanized steel.
- Tog-L-Loc and tabbed corners provide rigidity and durability.
- Integrated weather stripping incorporated into frame for additional strength and weather protection.
- Prepunch oblong mounting holes.
- Easy to motorize (optional motor pack model EAS).

### Blades

- 26 gauge 3105 mill finish aluminum.
- Galvanized reinforcement strip across top of blade for added strength and counter balancing and efficiency.
- Felt seal on leading edge of blade for tight closure and quiet operation.
- Flanged ends of blades provide additional weather seal protection.
- Center-mounted galvanized steel tie-rod connects blades for uniform opening and closing.
- 304 stainless steel pivot pins, rivets and bushings.
- Opens freely to allow full 90 degree opening and closing.
- Counter balanced blades allow shutter to be mounted vertically to 45 degrees.

### Ratings

- Maximum recommended velocity is 2,500 FPM of free area
- Temperature - -40 F to 180 F

### Options

- Motor packs



EAS1232MTR



EAS3850MTR

△ Contact Support Services at 800-961-7370 or [custserv.jax@solerpalau.com](mailto:custserv.jax@solerpalau.com) for shipping information. Lead-time will vary based on order details and quantity.

# AUTOMATIC WALL SHUTTER-SINGLE OR DOUBLE PANEL MODEL 556

## Single Panel

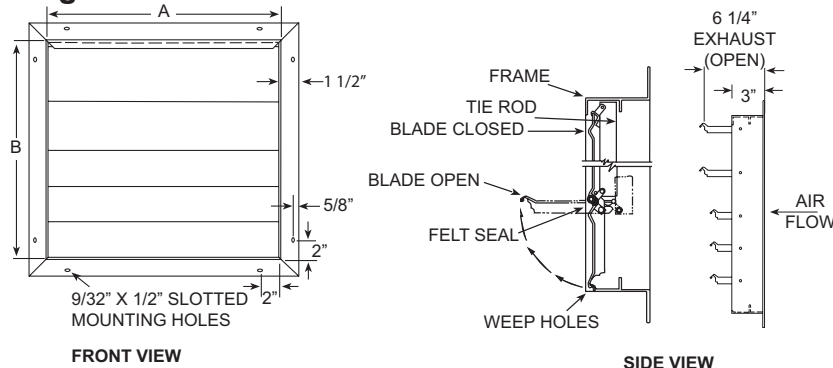

\*Side view of shutter frame and installed motor pack

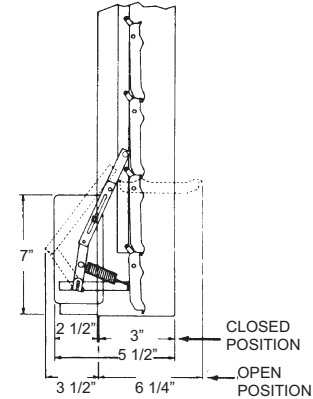

## Double Panel

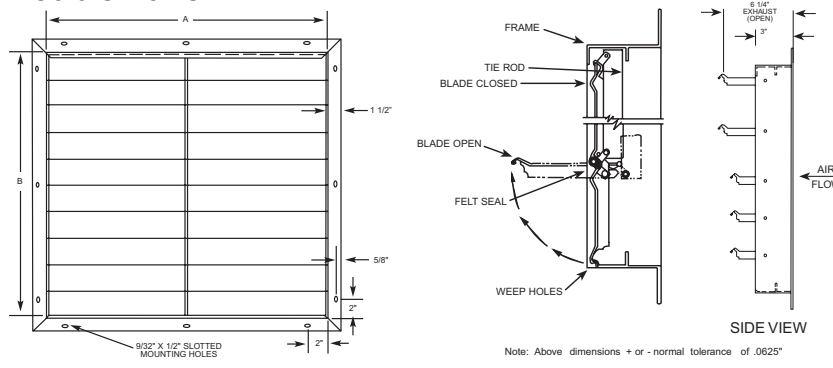

\*Side view of shutter frame and installed motor pack

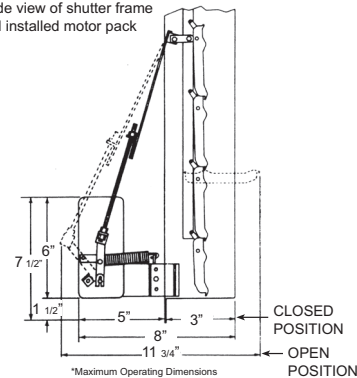

## STANDARD SIZES

### Dimensions in Inches

Part No.	Inside Frame Dimensions (W x H)	Overall Frame Dimensions (W x H)	Required Hole Opening (W x H)	Face Area (Sq. Ft.)	Est. Free Area (Sq. Ft.)	No. of Panels	Est. Shipping Weight (lbs)
556012 $\triangle$	12 x 12	15 x 15	12.5 x 12.5	1.00	.79	1	4.5
556016 $\blacklozenge$	16 x 16	19 x 19	16.5 x 16.5	1.78	1.44	1	6.5
556020 $\triangle$	20 x 20	23 x 23	20.5 x 20.5	2.78	2.28	1	8.5
556024 $\triangle$	24 x 24	27 x 27	24.5 x 24.5	4.00	3.32	1	11
556030 $\triangle$	30 x 30	33 x 33	30.5 x 30.5	6.25	5.16	1	15
556036 $\triangle$	36 x 36	39 x 39	36.5 x 36.5	9.00	7.44	1	19
556042 $\triangle$	42 x 42	45 x 45	42.5 x 42.5	12.25	10.25	2	29
556048 $\triangle$	48 x 48	51 x 51	48.5 x 48.5	16.00	12.92	2	35.5

Note: Dimension are approximate due to normal tolerances in the manufacturing process. Estimated Free Area calculation is based upon the following formula:  $MD[A+B+(N \times C)]/144$ . Free Area x FPM = CFM; actual performance may vary.

### Optional EAS Motor Pack Specifications

Motor Pack Part No.	Power Supply Required	Running AMPS	Stall Torque	Damper Panels	Lead Length
EAS1232MTR $\bullet$	115/230V, 60 Hz	.11/.07	77 ins. lbs.	Single	6"
EAS3850MTR $\bullet$	115/230V, 60 Hz	.11/.07	77 ins. lbs.	Double	6"

Ship Schedules:
$\bullet$ Next Day Shipment From Stock
$\blacklozenge$ 10 Day Shipment

Ship Schedules:
$\triangle$ Contact Support Services

Please refer to the General Catalog or contact the Factory for our Full Line of products available on standard shipping schedules.

# AUTOMATIC WALL SHUTTER-SINGLE OR DOUBLE PANEL MODEL EAS-RF

The Model EAS is a rear flanged exhaust shutter for areas where corrosion may be a problem. The frame and blades are mill finish aluminum. The blades have a galvanized reinforcement strip across the top of each blade for added strength and counter balancing efficiency. The blades have a felt seal on the leading edge for quiet closing and better protection from the weather. Ideal for use with direct-drive or belt-driven exhaust fans. Recommended for vertical mount exhaust applications only.

Sizes available – 12" W x 12" H to 48" W x 48" H.

Maximum free area velocity – 2,500 fpm.



## FEATURES

### Frame

- .062 mill finish 6063T5 or T6 extruded aluminum.
- Staked corners provide rigidity and durability.
- Integrated weather stripping incorporated into frame for additional strength and weather protection.
- Prepunched oblong mounting holes.
- Easy to motorize (optional motor pack model EAS).

### Blades

- 26 gauge 3105 mill finish aluminum.
- Galvanized reinforcement strip across top of blade for added strength and counter balancing and efficiency.
- Felt seal on leading edge of blade for tight closure and quiet operation.
- Flanged ends of blades provide additional weather seal protection.
- Center-mounted galvanized steel tie-rod connects blades for uniform opening and closing.
- 304 stainless steel pivot pins, rivets and bushings.
- Opens freely to allow full 90 degree opening and closing.
- Counter balanced blades allow shutter to be mounted vertically to 45 degrees.

### Ratings

- Maximum recommended velocity is 2,500 FPM Temperature - -40 F to 180 F

### Options

- Motor packs

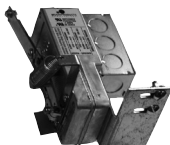

EAS1232MTR



EAS3850MTR

*Please refer to the General Catalog or contact the Factory for our Full Line of products available on standard shipping schedules.*

# AUTOMATIC WALL SHUTTER-SINGLE OR DOUBLE PANEL MODEL EAS-RF

## Single Panel

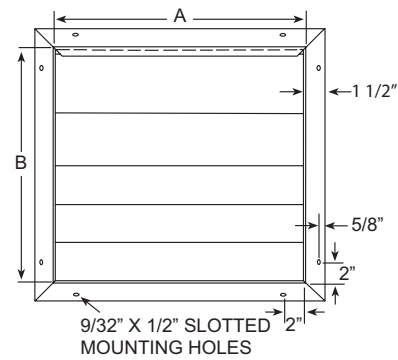

FRONT VIEW

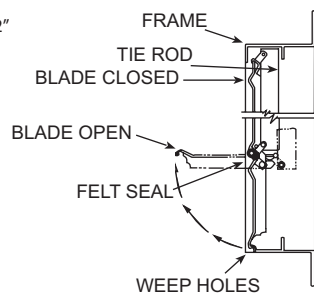

SIDE VIEW

Note: Above dimensions + or - normal tolerance of .0625"

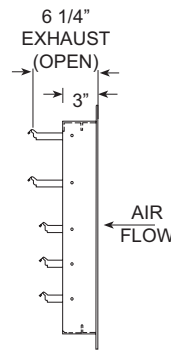

\*Side view of shutter frame and installed motor pack

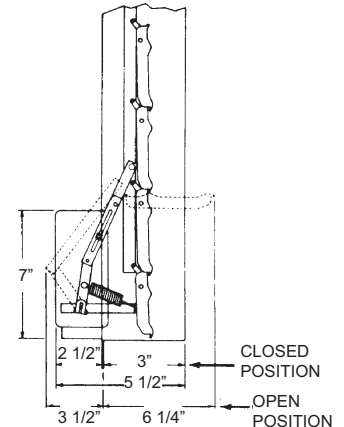

\*Maximum operating dimensions

## Double Panel

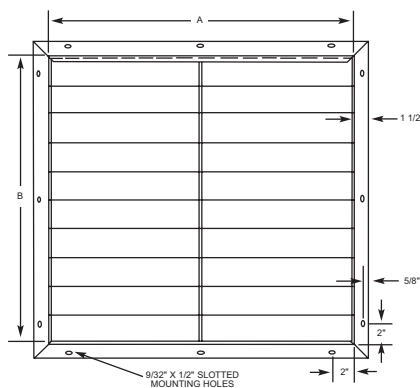

FRONT VIEW

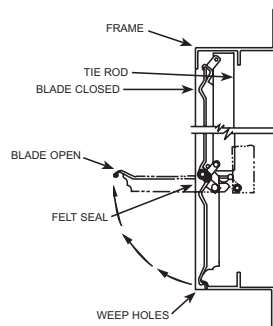

SIDE VIEW

Note: Above dimensions + or - normal tolerance of .0625"

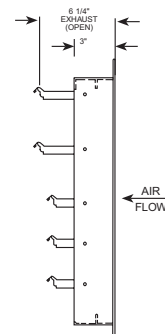

\*Side view of shutter frame and installed motor pack

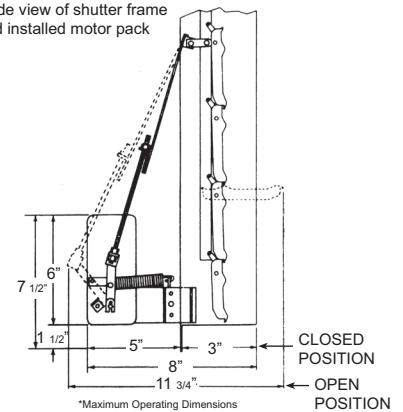

\*Maximum Operating Dimensions

## STANDARD SIZES

### Dimensions in Inches

Part No.	Inside Frame Dimensions (W x H)	Overall Frame Dimensions (W x H)	Required Hole Opening (W x H)	Face Area (Sq. Ft.)	Est. Free Area (Sq. Ft.)	No. of Panels	Est. Shipping Weight (lbs)
EAS12-RF •	12 x 12	15 x 15	12.5 x 12.5	1.00	.79	1	4.5
EAS16-RF •	16 x 16	19 x 19	16.5 x 16.5	1.78	1.44	1	6.5
EAS20-RF •	20 x 20	23 x 23	20.5 x 20.5	2.78	2.28	1	8.5
EAS24-RF •	24 x 24	27 x 27	24.5 x 24.5	4.00	3.32	1	11
EAS30-RF •	30 x 30	33 x 33	30.5 x 30.5	6.25	5.16	1	15
EAS36-RF •	36 x 36	39 x 39	36.5 x 36.5	9.00	7.44	1	19
EAS42-RF •	42 x 42	45 x 45	42.5 x 42.5	12.25	10.25	2	23
EAS48-RF •	48 x 48	51 x 51	48.5 x 48.5	16.00	12.92	2	27.5

Note: Dimension are approximate due to normal tolerances in the manufacturing process. Estimated Free Area calculation is based upon the following formula:  $MD[A+B+(N \times C)]/144$ . Free Area x FPM = CFM; actual performance may vary.

### Optional EAS Motor Pack Specifications

Motor Pack Part No.	Power Supply Required	Running AMPS	Stall Torque	Damper Panels	Lead Length
EAS1232MTR •	115/230V, 60 Hz	.11/.07	77 ins. lbs.	Single	6"
EAS3850MTR •	115/230V, 60 Hz	.11/.07	77 ins. lbs.	Double	6"

Please refer to the General Catalog or contact the Factory for our Full Line of products available on standard shipping schedules.

# AUTOMATIC WALL SHUTTER-SINGLE OR DOUBLE PANEL MODEL EAS-HDGS

The Model EAS-HDGS is a rear flanged exhaust shutter for applications that require higher velocities. The frame and blades are mill finish extruded aluminum with stainless steel tie rods. Ideal for use with direct drive or belt-driven exhaust fans. Recommended for vertical mount exhaust applications only.

Sizes available – 12" W x 12" H to 48" W x 48" H.

Maximum free area velocity – 3,250 fpm.



## FEATURES

### Frame

- .062 mill finish 6063T5/6 extruded aluminum.
- Staked corners provide rigidity and durability.
- Integrated weather stripping incorporated into frame for additional strength and weather protection.
- Prepunched oblong mounting holes.

### Blades

- .080 mill finish 6063T5/6 extruded aluminum.
- Stainless steel tie-rod connects blades for uniform opening and closing.
- 304 stainless steel pivot screws, rivets and bushings.
- Opens freely to allow full 90 degree opening and closing.

### Ratings

- Maximum recommended velocity is 3,250 FPM
- Temperature - -40 F to 180 F

△ Contact Support Services at 800-961-7370 or [custserv.jax@solerpalau.com](mailto:custserv.jax@solerpalau.com) for shipping information. Lead-time will vary based on order details and quantity.



# AUTOMATIC WALL SHUTTER-SINGLE OR DOUBLE PANEL MODEL EAS-HDGS

## Single Panel

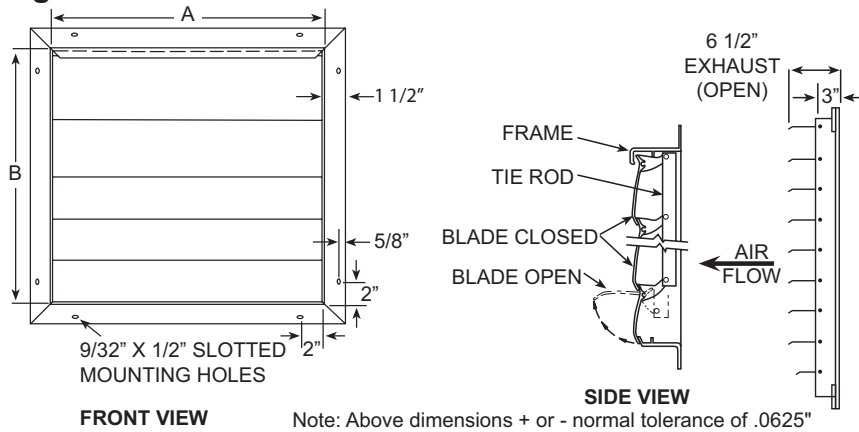

## Double Panel

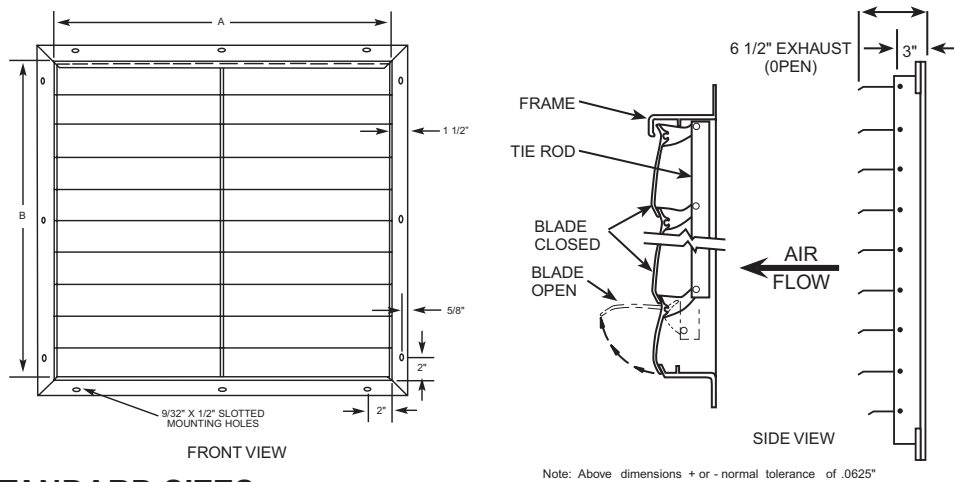

## STANDARD SIZES

### Dimensions in Inches

Part No.	Inside Frame Dimensions (W x H)	Overall Frame Dimensions (W x H)	Required Hole Opening (W x H)	Face Area (Sq. Ft.)	Est. Free Area (Sq. Ft.)	No. of Panels	Est. Shipping Weight (lbs)
EAS-HDGS12 $\triangle$	12 x 12	15 x 15	12.5 x 12.5	1.00	.79	1	6
EAS-HDGS16 $\triangle$	16 x 16	19 x 19	16.5 x 16.5	1.78	1.44	1	8
EAS-HDGS20 $\triangle$	20 x 20	23 x 23	20.5 x 20.5	2.78	2.28	1	12
EAS-HDGS24 $\triangle$	24 x 24	27 x 27	24.5 x 24.5	4.00	3.32	1	15
EAS-HDGS30 $\triangle$	30 x 30	33 x 33	30.5 x 30.5	6.25	5.16	1	20
EAS-HDGS36 $\triangle$	36 x 36	39 x 39	36.5 x 36.5	9.00	7.07	1	26
EAS-HDGS42 $\triangle$	42 x 42	45 x 45	42.5 x 42.5	12.25	10.25	2	31
EAS-HDGS48 $\triangle$	48 x 48	51 x 51	48.5 x 48.5	16.00	12.92	2	40

Note: Dimension are approximate due to normal tolerances in the manufacturing process.  
Estimated Free Area calculation is based upon the following formula:  $MD[A+B+(N \times C)]/144$ .  
Free Area x FPM = CFM; actual performance may vary.

Ship Schedules:
$\triangle$ Contact Support Services
$\blacklozenge$ 10 Day Shipment

Please refer to the General Catalog or contact the Factory for our Full Line of products available on standard shipping schedules.

# AUTOMATIC WALL SHUTTER-SINGLE OR DOUBLE PANEL MODEL FGS

The Model FGS is a rear flanged exhaust shutter for areas where corrosion is a known problem. The frame and blades are a heavy duty fiberglass pultrusion with stainless steel tie rods. Ideal for use with direct-drive or belt-driven exhaust fans in chemical plants and poultry/swine confinement operations. Recommended for vertical mount exhaust applications only.

Sizes available – 12" W x 12" H to 48" W x 48" H.

Maximum free area velocity – 2,500 fpm.



## FEATURES

### Frame

- Fiberglass pultrusion.
- Integrated weather stripping incorporated into frame for additional strength and weather protection.
- Prepunched oblong mounting holes.

### Ratings

- Maximum recommended velocity is 2,500 FPM Temperature - -40 F to 180 F

### Blades

- Fiberglass pultrusion.
- Center-mounted stainless steel tie-rod connects blades for uniform opening and closing.
- 304 stainless steel screws, pins, rivets and bushings.
- Opens freely to allow full 90 degree opening and closing.

△ Contact Support Services at 800-961-7370 or  
custserv.jax@solerpalau.com for shipping information.  
Lead-time will vary based on order details and quantity.

*Please refer to the General Catalog or contact the Factory for our Full Line of products available on standard shipping schedules.*

# AUTOMATIC WALL SHUTTER-SINGLE OR DOUBLE PANEL MODEL FGS

## Single Panel

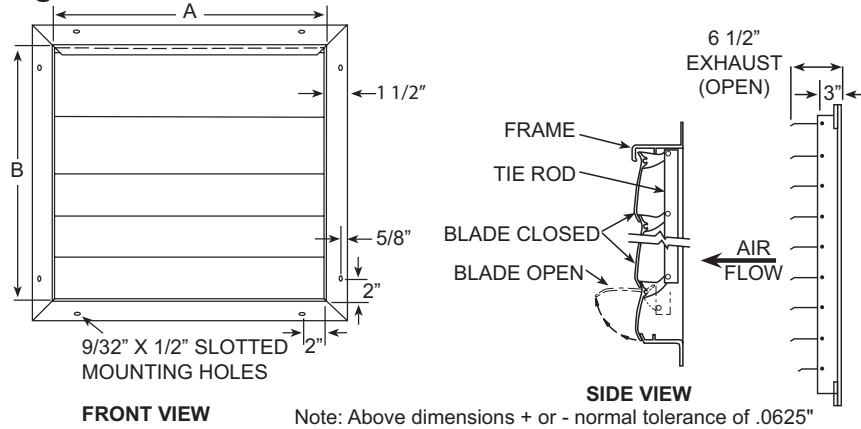

## Double Panel

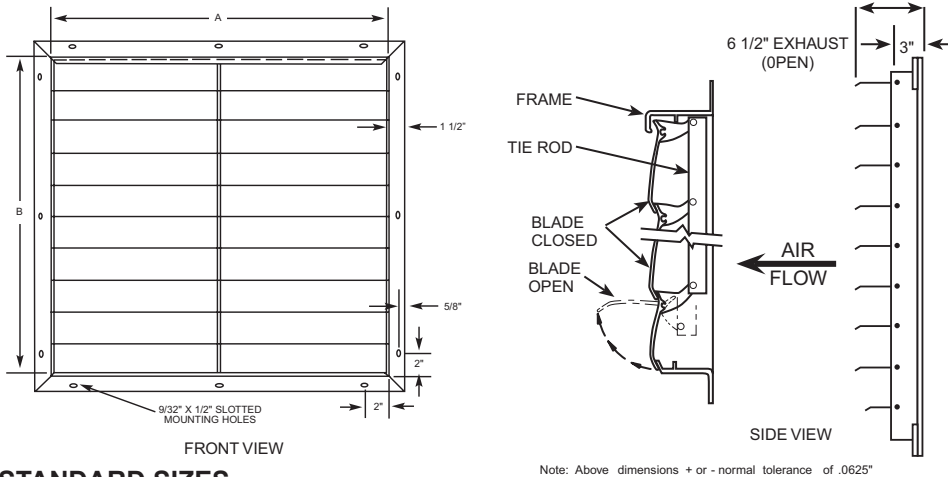

## STANDARD SIZES

### Dimensions in Inches

Part No.	Inside Frame Dimensions (W x H)	Overall Frame Dimensions (W x H)	Required Hole Opening (W x H)	Face Area (Sq. Ft.)	Est. Free Area (Sq. Ft.)	No. of Panels	Est. Shipping Weight (lbs)
FGS12 $\triangle$	12 x 12	15 x 15	12.5 x 12.5	1.00	.79	1	5.5
FGS16 $\triangle$	16 x 16	19 x 19	16.5 x 16.5	1.78	1.44	1	6
FGS20 $\triangle$	20 x 20	23 x 23	20.5 x 20.5	2.78	2.28	1	8.5
FGS24 $\triangle$	24 x 24	27 x 27	24.5 x 24.5	4.00	3.32	1	11
FGS30 $\triangle$	30 x 30	33 x 33	30.5 x 30.5	6.25	5.16	1	15
FGS36 $\triangle$	36 x 36	39 x 39	36.5 x 36.5	9.00	7.44	1	20
FGS42 $\triangle$	42 x 42	45 x 45	42.5 x 42.5	12.25	10.25	2	28
FGS48 $\triangle$	48 x 48	51 x 51	48.5 x 48.5	16.00	12.92	2	35

Note: Dimension are approximate due to normal tolerances in the manufacturing process. Estimated Free Area calculation is based upon the following formula:  $MD[A+B+(N \times C)]/144$ . Free Area x FPM = CFM; actual performance may vary.

Ship Schedules:  
 $\triangle$  Contact Support Services

# AUTOMATIC WALL SHUTTER- MODEL 304SS

The Model 304SS is a rear flanged exhaust shutter for areas that require extreme corrosion resistance. The frame and blades are 304 stainless steel with stainless steel tie rods and hardware. Ideal for use with direct-drive or belt-driven exhaust fans in chemical plants and food processing operations. Recommended for vertical mount exhaust applications only.

Sizes available – 12" W x 12" H to 36" W x 36" H.

Maximum free area velocity – 2,500 fpm.



## FEATURES

### Frame

- .039 min. gauge 304 stainless steel.
- Welded frame provide rigidity and durability.
- Integrated weather stripping incorporated into frame for additional strength and weather protection.
- Prepunch oblong mounting holes.

### Blades

- .016 gauge 304 stainless steel.
- Stainless steel reinforcement rod fasten blades to frame for added strength.
- Center-mounted stainless steel tie-rod connects blades for uniform opening and closing on face of the unit.
- 304 stainless steel rods, rivets and bushings.
- Opens freely to allow full 90 degree opening and closing

### Ratings

- Maximum recommended velocity is 2,500 FPM
- Temperature -40 F to 180 F

△ Contact Support Services at 800-961-7370 or  
custserv.jax@solerpalau.com for shipping information.  
Lead-time will vary based on order details and quantity.

*Please refer to the General Catalog or contact the Factory for our Full Line of products available on standard shipping schedules.*

# AUTOMATIC WALL SHUTTER- MODEL 304SS

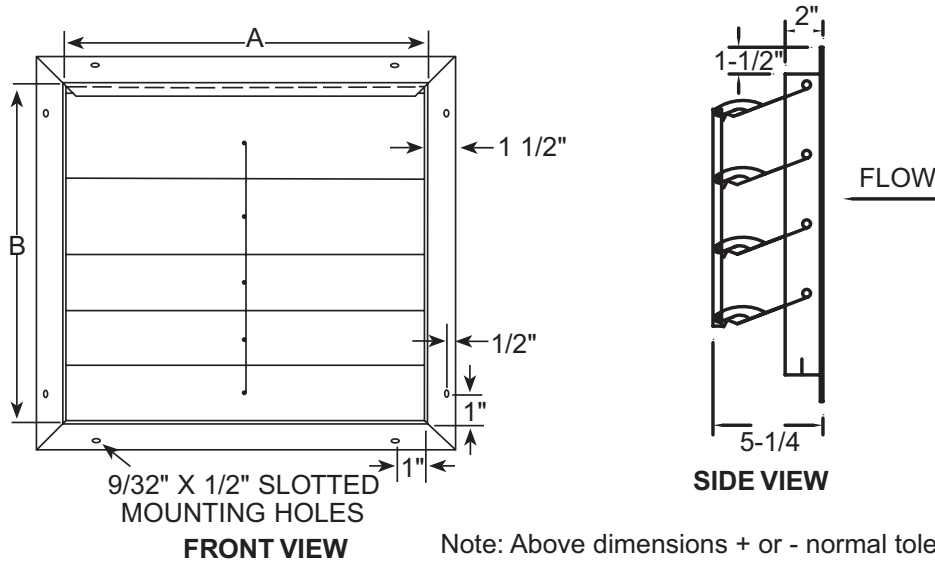

## STANDARD SIZES Dimensions in Inches

Part No.	Inside Frame Dimensions (W x H)	Overall Frame Dimensions (W x H)	Required Hole Opening (W x H)	Face Area (Sq. Ft.)	Est. Free Area (Sq. Ft.)	No. of Panels	Est. Shipping Weight (lbs)
304SS12 △	12 x 12	15 x 15	12.5 x 12.5	1.00	.82	1	4.5
304SS16 △	16 x 16	19 x 19	16.5 x 16.5	1.78	1.51	1	6
304SS20 △	20 x 20	23 x 23	20.5 x 20.5	2.78	2.41	1	8.5
304SS24 △	24 x 24	27 x 27	24.5 x 24.5	4.00	3.25	2	11.5
304SS30 △	30 x 30	33 x 33	30.5 x 30.5	6.25	5.44	2	16
304SS36 △	36 x 36	39 x 39	36.5 x 36.5	9.00	7.69	2	21

Note: Dimension are approximate due to normal tolerances in the manufacturing process.  
 Estimated Free Area calculation is based upon the following formula:  $MD[A+B+ (N \times C)]/144$ .  
 Free Area x FPM = CFM; actual performance may vary.

Ship Schedules:
△ Contact Support Services

Please refer to the General Catalog or contact the Factory for our Full Line of products available on standard shipping schedules.

# AUTOMATIC WALL SHUTTER MODEL EASB & EASW

The Models EASB & EASW are rear flanged shutters for areas where corrosion is a known. The frame is painted extruded aluminum with UV PVC blades with yellow zinc dichromate rods full length of the blades. Ideal for direct-drive or cone or slant-wall exhaust fans in poultry or swine operations. Recommended for vertical mount applications only. Available in white or black.

Sizes available – 36”, 39”, 51”, 54” square.

Maximum free area velocity – 1,500 fpm.



## FEATURES

### Frame

- .080 extruded aluminum painted black or white
- Staked corners provide rigidity and durability.
- Integrated weather stripping incorporated into frame for additional strength and weather protection.
- Prepunched oblong mounting holes.

### Ratings

- Maximum recommended velocity is 1,500 FPM
- Temperature - -40 F to 180 F

### Blades

- 3” wide black or white PVC blades
- Yellow zinc dichromate rods connect blades for uniform opening and closing
- Opens freely to allow full 90 degree opening and closing

△ Contact Support Services at 800-961-7370 or  
custserv.jax@solerpalau.com for shipping information.  
Lead-time will vary based on order details and quantity.

# AUTOMATIC WALL SHUTTER MODEL EASB & EASW

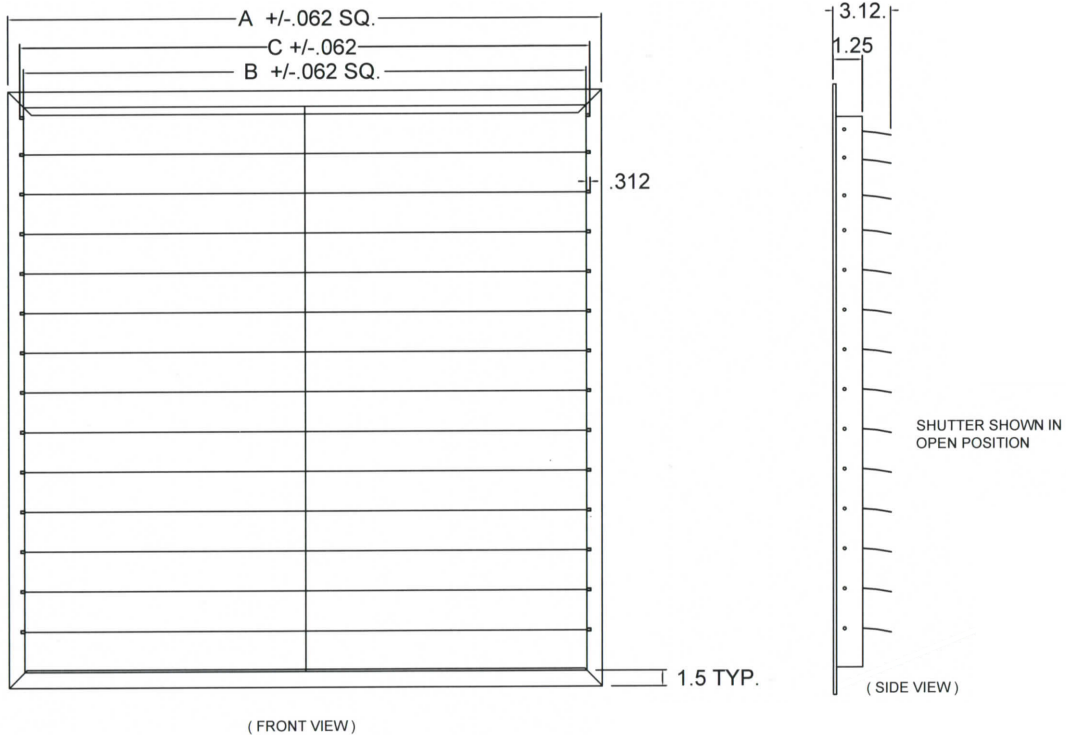

## STANDARD SIZES Dimensions in Inches

Part No.	Overall (A) Frame Dimensions (W x H)	Inside (B) Frame Dimensions (W x H)	Required (C) Hole Opening (W x H)	# of Panels	Est. Shipping Weight (lbs)
EASB36 △	39 x 39	35.87 x 35.87	36.5 x 36.5	2	12
EASB39 △	42 x 42	38.87 x 38.87	39.5 x 39.5	2	13.5
EASB51 △	54 x 54	50.87 x 50.87	51.5 x 51.5	3	19.5
EASB54 △	57 x 57	53.87 x 53.87	54.5 x 54.5	3	28
EASW36 △	39 x 39	35.87 x 35.87	36.5 x 36.5	2	12
EASW39 △	42 x 42	38.87 x 38.87	39.5 x 39.5	2	13.5
EASW51 △	54 x 54	50.87 x 50.87	51.5 x 51.5	3	19.5
EASW54 △	57 x 57	53.87 x 53.87	54.5 x 54.5	3	28

Note: Dimension are approximate due to normal tolerances in the manufacturing process.

Ship Schedules:
△ Contact Support Services

Please refer to the General Catalog or contact the Factory for our Full Line of products available on standard shipping schedules.



# EXTRUDED ALUMINUM MOTORIZED DAMPER MODEL AMD

The Model AMD is a heavy duty motorized volume control damper. The 1-1/2" flanged frame has welded corners for added strength. The 6" wide blades are center-pivoted for a full 90° rotation with parallel blade action. The stainless steel jamb seals help in keeping out light, air, and moisture. The dampers can be used for exhaust or supply applications and can be mounted in either a vertical or horizontal position; typically walls or curbs. Available in Extruded Aluminum (AMD) comes standard with an internally mounted factory installed 120/240 volt power open / spring close motor with an end switch.



Sizes available – 12" W x 12" H to 48" W x 48" H.

Maximum free area velocity – 3,500 fpm.

## FEATURES

### Frame

- 2" deep x 1-1/2" flanged x .125 thick extruded aluminum.

### Blades

- 6" wide x .080 thick extruded aluminum.  
Parallel Blade Action.

### Construction

- "TIG" welded frames.

### Seals

- Stainless Steel Jamb Seals.

### Tie Rod

- .125 thick extruded aluminum tie rods and blade clips. On-blade type.

### Bushings

- Nylon

### Mounting Holes

- 9/32" x 1/2" slotted.

### Finish

- Mill

### Performance Criteria:

- 3,500 fpm Maximum Velocity.
- 4" wg Maximum Pressure.
- 122 Degree Maximum Temperature.

△ Contact Support Services at 800-961-7370 or  
custserv.jax@solerpalau.com for shipping information.  
Lead-time will vary based on order details and quantity.

Please refer to the General Catalog or contact the Factory for our Full Line of products available on standard shipping schedules.

# EXTRUDED ALUMINUM MOTORIZED DAMPER MODEL AMD

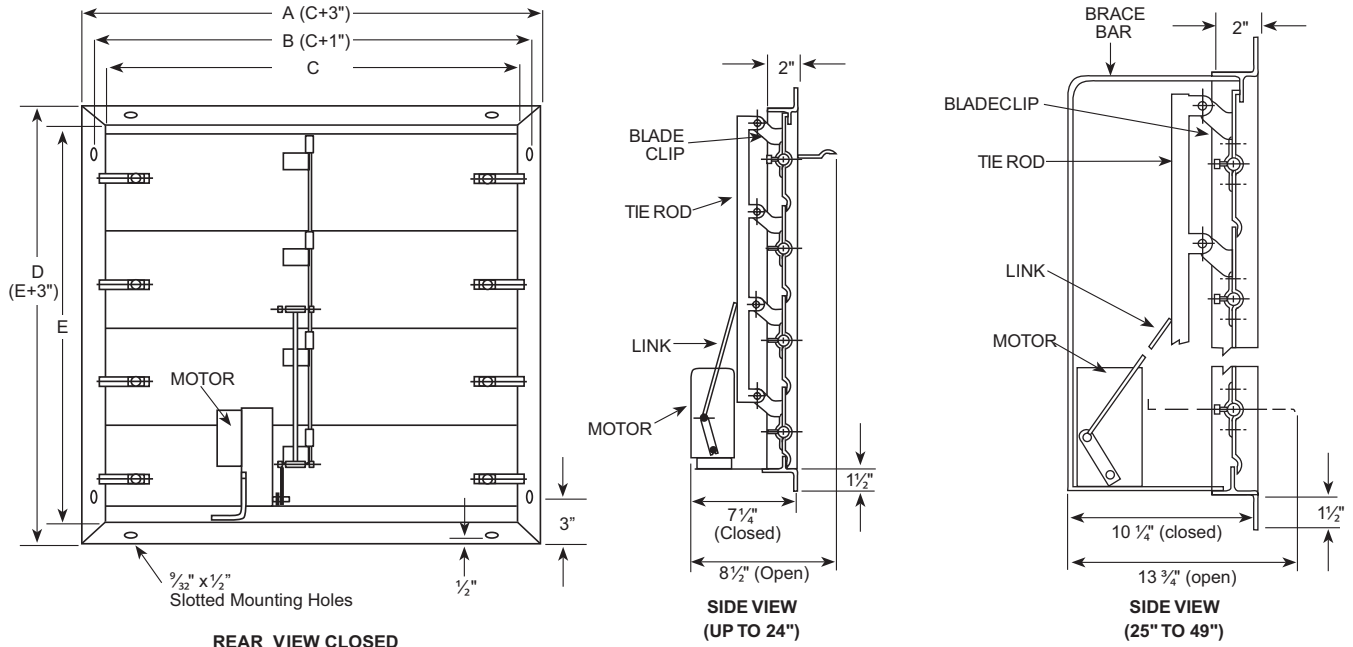

Note: Above dimensions+ or - normal tolerance of .0625".

## STANDARD SIZES Dimensions in Inches

Part No.	Overall (A & D) Frame Dimensions (W x H)	Inside (C & E) Frame Dimensions (W x H)	Required (B) Hole Opening (W x H)	Face Area (Sq. Ft. )	Est. Free Area (Sq. Ft.)	Est. Shipping Weight (lbs)
AMD12	15 x 15	12 x 12	13 x 13	1.00	.84	10
AMD16	19 x 19	16 x 16	17 x 17	1.78	1.67	12
AMD20	23 x 23	20 x 20	21 x 21	2.78	2.05	15
AMD24	27 x 27	24 x 24	25 x 25	4.00	3.59	17
AMD30	33 x 33	30 x 30	31 x 31	6.25	5.68	36
AMD36	39 x 39	36 x 36	37 x 37	9.00	8.25	47
AMD42	45 x 45	42 x 42	43 x 43	12.25	11.31	55
AMD48	51 x 51	48 x 48	49 x 49	16.00	14.84	67

Note: Dimensions are approximate due to normal tolerances in the manufacturing process. Estimated Free Area calculation is based upon the following formula:  $MD[A+B+(N \times C)]/144$ . Free Area x FPM = CFM; actual performance may vary.

## MOTOR SPECS

Motor Manufacturer	Model Number	Power Supply Required	Motor Type	Temperature Range F°
Belimo •	TF120-S	120/240 V 50/60 Hz	2 position Spring Return	-22 to 122

Ship Schedules:	
•	Next Day Shipment From Stock
△	Contact Support Services

Please refer to the General Catalog or contact the Factory for our Full Line of products available on standard shipping schedules.

# GALVANIZED MOTORIZED DAMPER MODEL GMD

The Model GMD is a heavy duty motorized volume control damper. The 1-1/2" flanged frame has welded corners for added strength. The 6" wide blades are center-pivoted for a full 90° rotation with parallel blade action. The stainless steel jamb seals help in keeping out light, air, and moisture. The dampers can be used for exhaust or supply applications and can be mounted in either a vertical or horizontal position; typically walls or curbs. Available Galvanized Steel (GMD) and comes standard with an internally mounted factory installed 120/240 volt power open / spring close motor with an end switch.



Sizes available – 12" W x 12" H to 48" W x 48" H.

Maximum free area velocity – 3,500 fpm.

## FEATURES

### Frame

- 2" deep x 1-1/2" flanged x 14 gauge Galvanized Steel.

### Blades

- 6" wide x 16 gauge Galvanized Steel. Parallel Blade Action.

### Construction

- "MIG" welded frames.

### Seals

- Stainless Steel Jamb Seals.

### Tie Rod

- 11 gauge Galvanized Steel tie rods and blade clips. On-blade type.

### Bushings

- Brass

### Mounting Holes

- 9/32" x 1/2" slotted.

### Finish

- Galvanized

### Performance Criteria:

- 3,500 fpm Maximum Velocity.
- 4" wg Maximum Pressure.
- 122 Degree Maximum Temperature.

# GALVANIZED MOTORIZED DAMPER MODEL GMD

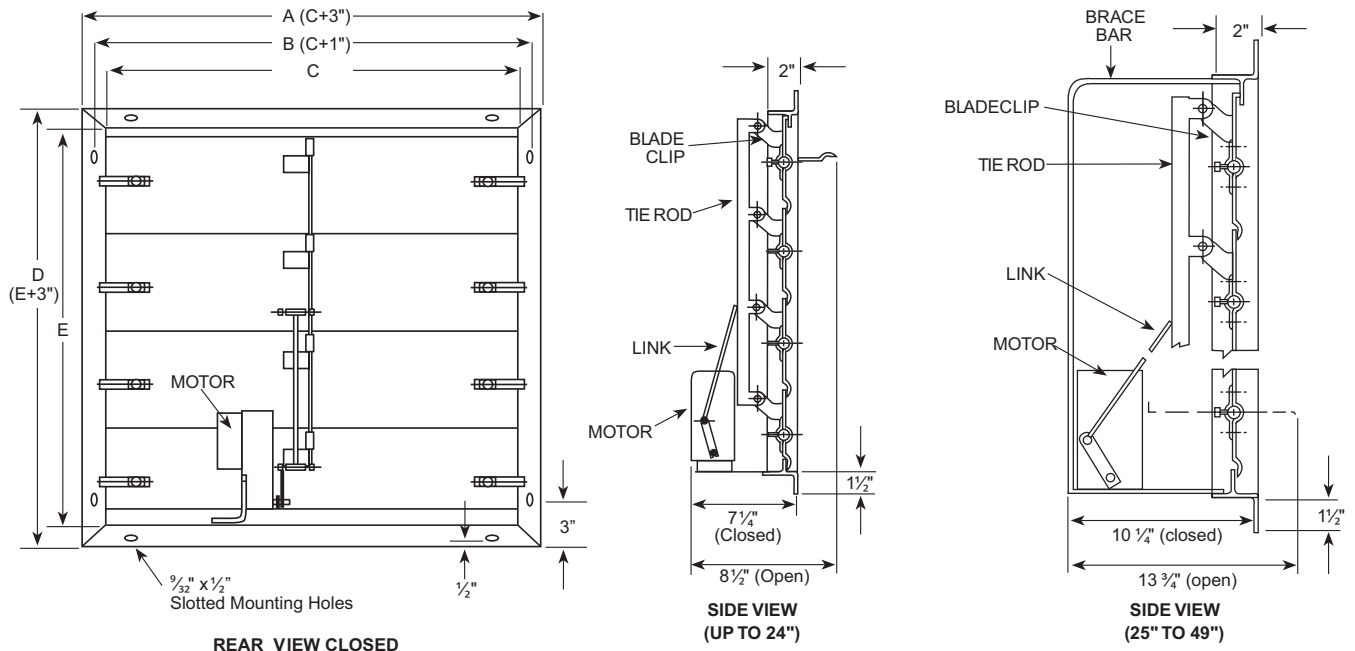

## STANDARD SIZES

### Dimensions in Inches

Part No.	Overall (A & D) Frame Dimensions (W x H)	Inside (C & E) Frame Dimensions (W x H)	Required (B) Hole Opening (W x H)	Face Area (Sq. Ft. )	Est. Free Area (Sq. Ft.)	Est. Shipping Weight (lbs)
GMD12 ●	15 x 15	12 x 12	13 x 13	1.00	.84	14
GMD16 ●	19 x 19	16 x 16	17 x 17	1.78	1.67	21
GMD20 ●	23 x 23	20 x 20	21 x 21	2.78	2.05	25
GMD24 ●	27 x 27	24 x 24	25 x 25	4.00	3.59	32
GMD30 ●	33 x 33	30 x 30	31 x 31	6.25	5.68	53
GMD36 ●	39 x 39	36 x 36	37 x 37	9.00	8.25	67
GMD42 ●	45 x 45	42 x 42	43 x 43	12.25	11.31	83
GMD48 ●	51 x 51	48 x 48	49 x 49	16.00	14.84	98

**Note:** Dimensions are approximate due to normal tolerances in the manufacturing process. Estimated Free Area calculation is based upon the following formula:  $MD[A+B+(N \times C)]/144$ . Free Area x FPM = CFM; actual performance may vary.

## MOTOR SPECS

Motor Manufacturer	Model Number	Power Supply Required	Motor Type	Temperature Range F°
Belimo ●	TF120-S	120/240 V 50/60 Hz	2 position Spring Return	-22 to 122

Ship Schedules:
● Next Day Shipment From Stock

Please refer to the General Catalog or contact the Factory for our Full Line of products available on standard shipping schedules.

# ALUMINUM MOTORIZED HAT CHANNEL DAMPER MODEL

The Model ACD is an Extruded Aluminum motorized volume control damper. The hat channel frame is 5" wide with 7" wide center-pivoted blades for a full 90° rotation with parallel blade action. The TPV blade and stainless steel jamb seals help in keeping out light, air, and moisture. The dampers can be used for exhaust or supply applications and can be mounted in a vertical or horizontal position; typically walls, curbs, or ductwork. Available in Extruded Aluminum (ACD) and comes standard with an internally mounted factory installed 100-240 volt power open / spring close motor with an end switch.



Sizes available – 12" W x 12" H to 48" W x 48" H.

Maximum free area velocity – 3,500 fpm.

## FEATURES

### Frame

- 5" x 1" x .100 thick Extruded Aluminum Hat Channel.

### Blades

- 7" wide x .080 thick extruded aluminum.  
Parallel Blade Action.

### Seals

- Blade – Extruded TPV (-70°F to +280° F).
- Jamb – Stainless Steel..

### Tie Rod

- On-blade type.

### Bushings

- Nylon

### Finish

- Mill

### Performance Criteria:

- 3,500 fpm Maximum Velocity.
- 4" wg Maximum Pressure.
- 122 Degree Maximum Temperature.

△ Contact Support Services at 800-961-7370 or [custserv.jax@solerpalau.com](mailto:custserv.jax@solerpalau.com) for shipping information. Lead-time will vary based on order details and quantity.

# ALUMINUM MOTORIZED HAT CHANNEL DAMPER MODEL ACD

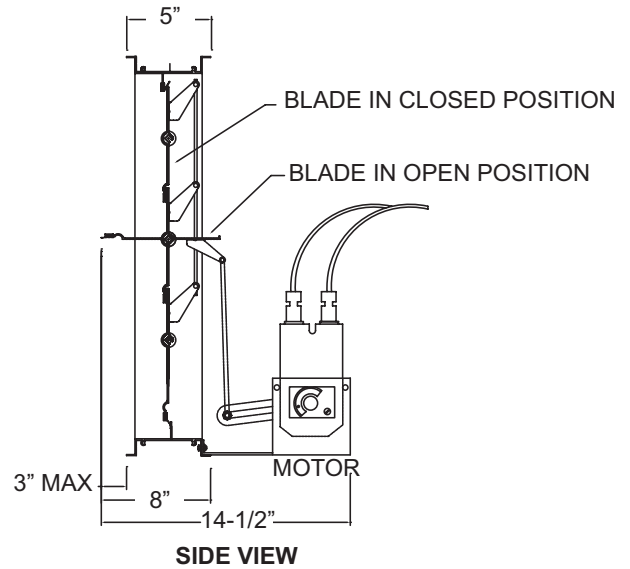
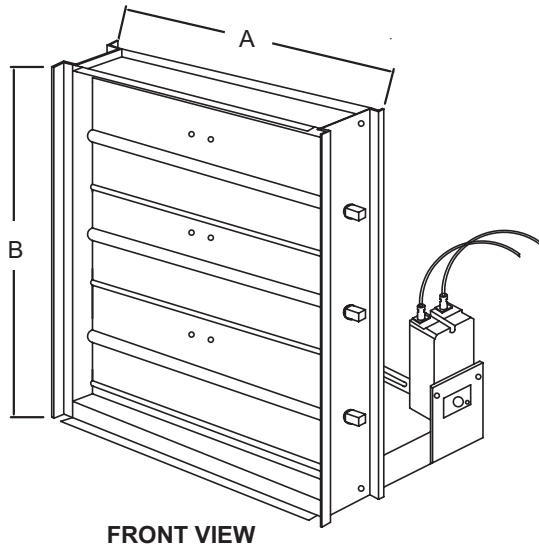

## STANDARD SIZES

Dimensions in Inches

Part No.	Overall Frame Dimensions (W x H)	Face Area (Sq. Ft.)	Est. Free Area (Sq. Ft.)	Est. Shipping Weight (lbs)
ACD12 $\triangle$	11.75 x 11.75	.96	.37	5
ACD16 $\triangle$	15.75 x 15.75	1.73	1.05	7
ACD20 $\triangle$	19.75 x 19.75	2.71	2.13	10.5
ACD24 $\triangle$	23.75 x 23.75	3.92	3.17	13
ACD30 $\triangle$	29.75 x 29.75	6.15	5.11	18.5
ACD36 $\triangle$	35.75 x 35.75	8.88	7.56	25
ACD42 $\triangle$	41.75 x 41.75	12.11	10.49	34
ACD48 $\triangle$	47.75 x 47.75	15.84	13.90	42

**Note:** Dimensions are approximate due to normal tolerances in the manufacturing process. Estimated Free Area calculation is based upon the following formula:  $MD[A+B+(N \times C)]/144$ . Free Area x FPM = CFM; actual performance may vary.

## MOTOR SPECS

Motor Manufacturer	Model Number	Power Supply Required	Motor Type	Temperature Range F°
Belimo ●	TF120-S	120/240 V 50/60 Hz	2 position Spring Return	-22 to 122

Ship Schedules:
● Next Day Shipment From Stock
$\triangle$ Contact Support Services

Please refer to the General Catalog or contact the Factory for our Full Line of products available on standard shipping schedules.

# ALUMINUM FIXED LOUVER MODEL AFL

The Model AFL fixed louvers provide good protection from rain and weather at an economical price. The channel frame is 4" deep with K-style nondrainable 45 degree blades. Available in Aluminum (AFL) and comes standard with a birdscreen on the back.

Single panel sizes available: 18" W x 18" H to 48" W x 48" H.

## FEATURES

### Frame

- 4" deep channel x .060 thick aluminum

### Blades

- K style, .060 thick Aluminum, positioned at a 45 degree angle and spaced approximately 4" centers.

### Construction

- Tabbed

### Birdscreen

- 1/2" Flattened Aluminum in a removable frame mounted on the interior

### Finish

- Mill





# ALUMINUM FIXED LOUVER MODEL AFL

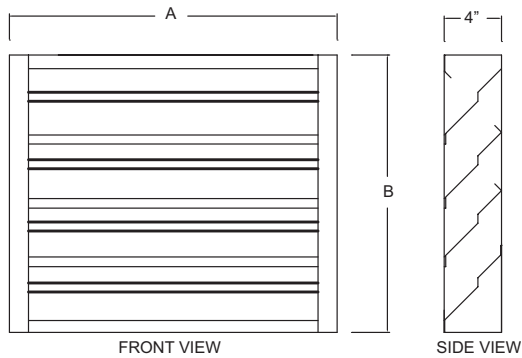

NOTE: Above "A" and "B" dimensions are undersized by 1/2" + or - normal tolerance of .0625

Part No.	Overall Frame Dimensions (W x H) in. inches	Free Area (Sq. ft.)	Est. Shipping Weight (lbs)
AFL18 ●	17.5 x 17.5	.87	8
AFL24 ●	23.5 x 23.5	1.77	14
AFL30 ●	29.5 x 29.5	2.77	20
AFL36 ●	35.5 x 35.5	3.98	26
AFL48 ●	47.5 x 47.5	7.07	40

Note: Estimated free area calculations are based upon AMCA standard 500-L, actual performance may vary.

## Pressure Drop

Standard Air - .075lbs per cubic foot  
Test size - 48"x 48" (Intake)

Ratings do not include the effect of a birdscreen

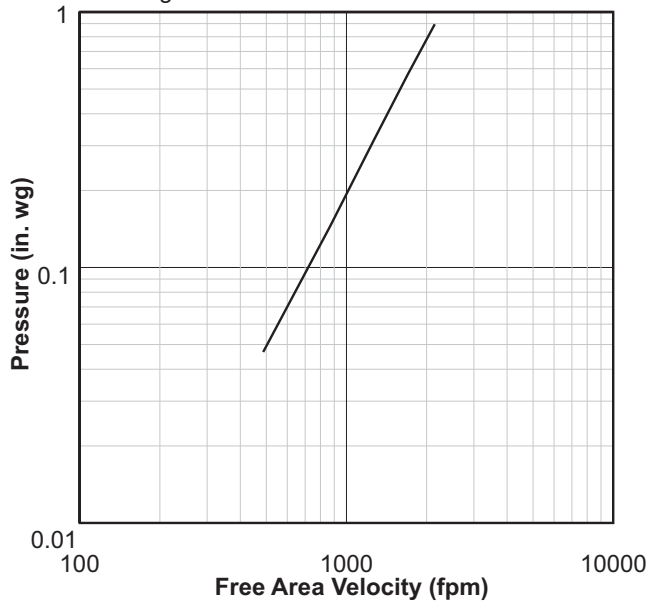

## WATER PENETRATION

Standard Air - .075lbs per cubic foot  
Test size - 48"x 48" for a 15 minute duration

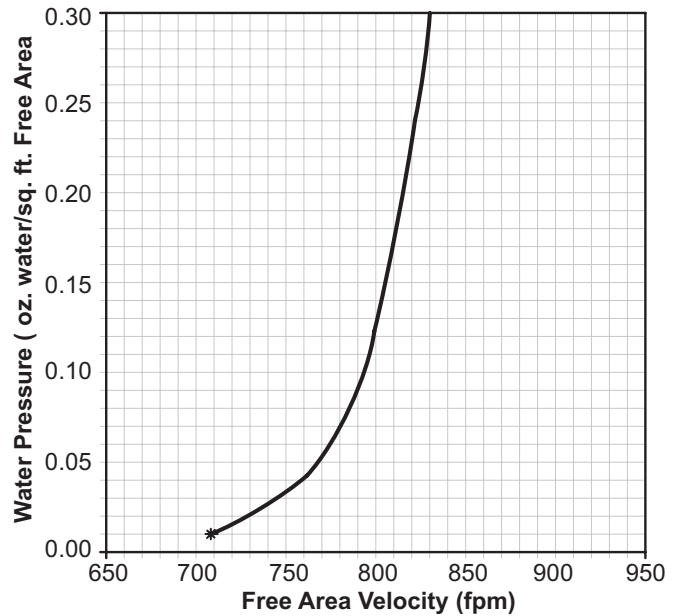

The beginning point of water penetration at .01 oz./sq. ft. is 709 fpm free area velocity.

S&P USA certifies that the Model AFL was tested according to AMCA Standard 500. These tests were performed under certain sets of laboratory conditions. These performance ratings do not guarantee that other environmental conditions may actually occur. Use safety factors when selecting louver sizes based upon performance.

Ship Schedules:
● Next Day Shipment From Stock

Please refer to the General Catalog or contact the Factory for our Full Line of products available on standard shipping schedules.

# GALVANNEAL STEEL FIXED LOUVER MODEL GFL

The Model GFL fixed louvers provide good protection from rain and weather at an economical price. The channel frame is 4" deep with K-style nondrainable 45 degree blades. Available in Galvanneal (GFL) and comes standard with a birdscreen on the back.

Single panel sizes available: 18" W x 18" H to 48" W x 48" H.

## FEATURES

### Frame

- 4" deep channel x 16 gauge A-60 galvanneal steel

### Blades

- K style, 16 gauge A-60 galvanneal steel, positioned at a 45 degree angel and spaced approximately 4" centers

### Construction

- Tabbed

### Finish

- Mill



# GALVANNEAL STEEL FIXED LOUVER MODEL GFL

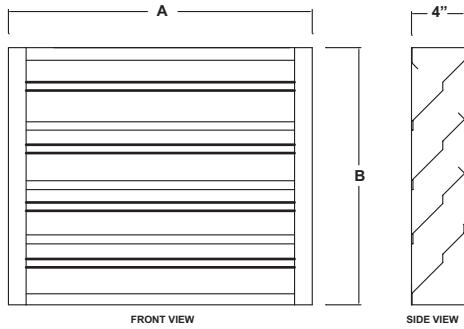

NOTE: Above "A" and "B" dimensions are undersized by 1/2" + or - normal tolerance of .0625

Part No.	Overall Frame Dimensions (W x H) in. inches	Free Area (Sq. ft.)	Est. Shipping Weight (lbs)
GFL18 ●	17.5 x 17.5	.87	18
GFL24 ●	23.5 x 23.5	1.77	30
GFL30 ●	29.5 x 29.5	2.77	45
GFL36 ●	35.5 x 35.5	3.98	60
GFL48 ●	47.5 x 47.5	7.07	100

Note: Estimated free area calculations are based upon AMCA standard 500-L, actual performance may vary.

## Pressure Drop

Standard Air - .075lbs per cubic foot  
Test size - 48"x 48" (Intake)

Ratings do not include the effect of a birdscreen

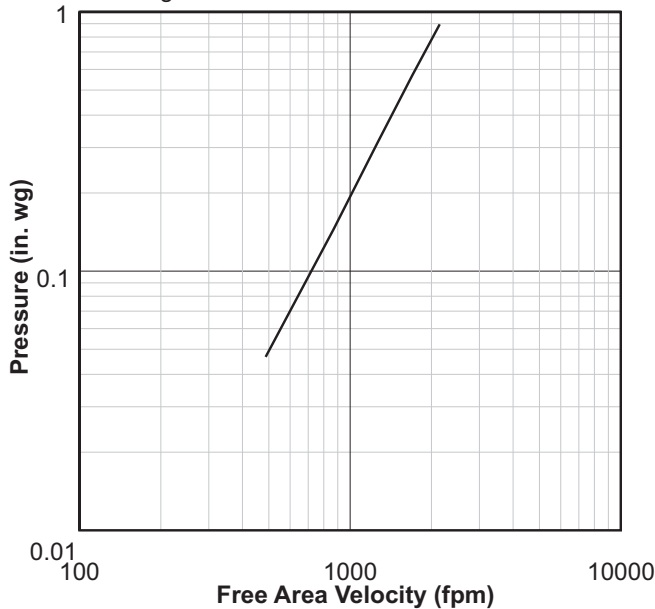

## WATER PENETRATION

Standard Air - .075lbs per cubic foot  
Test size - 48"x 48" for a 15 minute duration

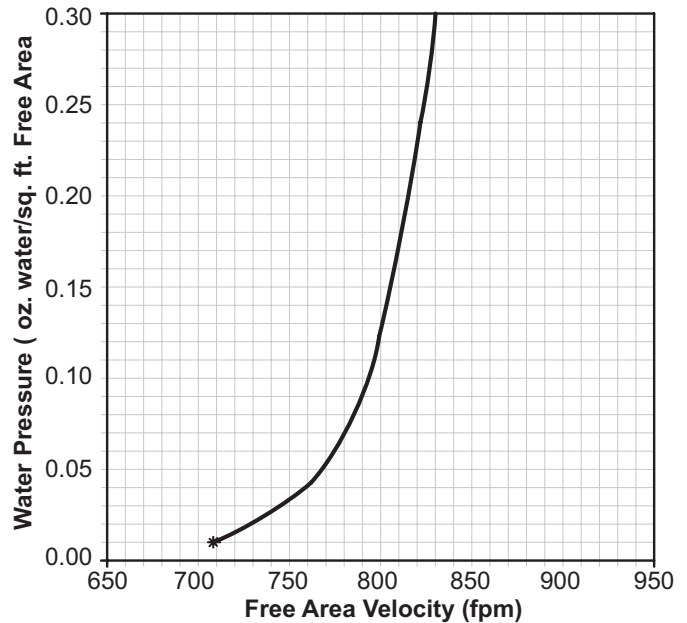

The beginning point of water penetration at .01 oz./sq. ft. is 709 fpm free area velocity.

S&P USA certifies that the Model GFL was tested according to AMCA Standard 500. These tests were performed under certain sets of laboratory conditions. These performance ratings do not guarantee that other environmental conditions may actually occur. Use safety factors when selecting louver sizes based upon performance.

Ship Schedules:
● Next Day Shipment From Stock

Please refer to the General Catalog or contact the Factory for our Full Line of products available on standard shipping schedules.

# EXTRUDED ALUMINUM DRAINABLE BLADE FIXED LOUVER MODEL DFL

The Model DFL offers excellent resistance to rain and weather. The drainable blade design channels water away from the blades and down the jambs. This eliminates water cascading from blade to blade. The channel frame is 4" deep with drainable 45 degree blades. This model is only available in extruded aluminum and comes standard with a birdscreen on the back.

Single panels sizes available: 18" W x 18" H to 48" W x 48" H.

## FEATURES

### Finish

- Mill

### Frame

- 4" deep channel x .080 thick extruded aluminum

### Blades

- Drainable style, .080 thick extruded aluminum, positioned at a 45 degree angle and spaced approximately 4" centers

### Construction

- Screwed

### Birdscreen

- 1/2" Flattened Aluminum in a removable frame mounted on the interior

### Options

- 1-1/2" Mounting Flange



# EXTRUDED ALUMINUM DRAINABLE BLADE FIXED LOUVER MODEL DFL

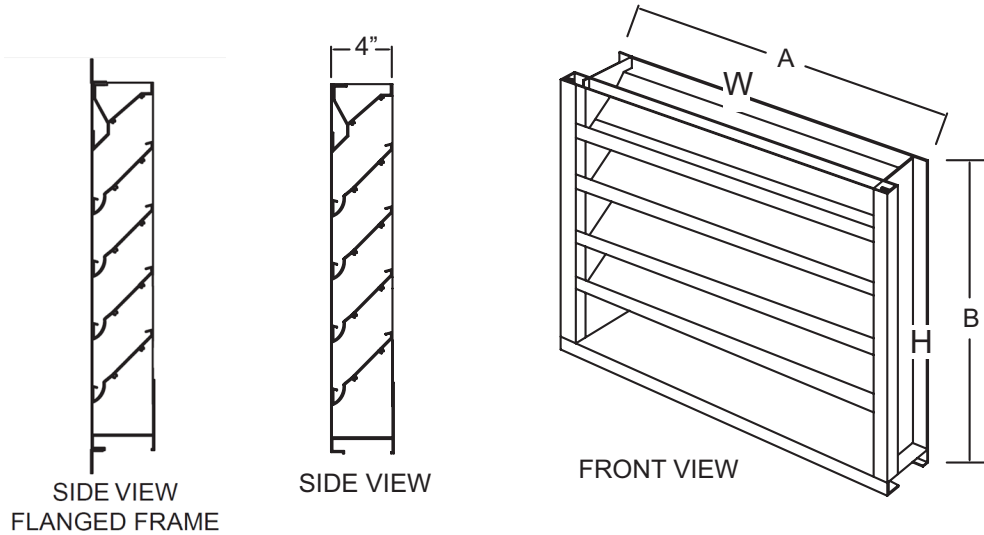

Part No.	Overall Frame Dimensions (W x H) in. inches	Free Area (Sq. ft.)	Est. Shipping Weight (lbs)
DFL18	17.5 x 17.5	1.00	10
DFL24	23.5 x 23.5	1.76	14
DFL30	29.5 x 29.5	3.16	22
DFL36	35.5 x 35.5	4.41	28
DFL48	47.5 x 47.5	8.37	47

- Notes:
- Overall Frame Dimensions have a normal tolerance of .0625".
  - Estimated free area calculations are based upon AMCA standard 500-L, actual performance may vary.
  - For flanged version of louver, add "-F" to the end of the Part No. EX: DFL18-F

Ship Schedules:
● Next Day Shipment From Stock

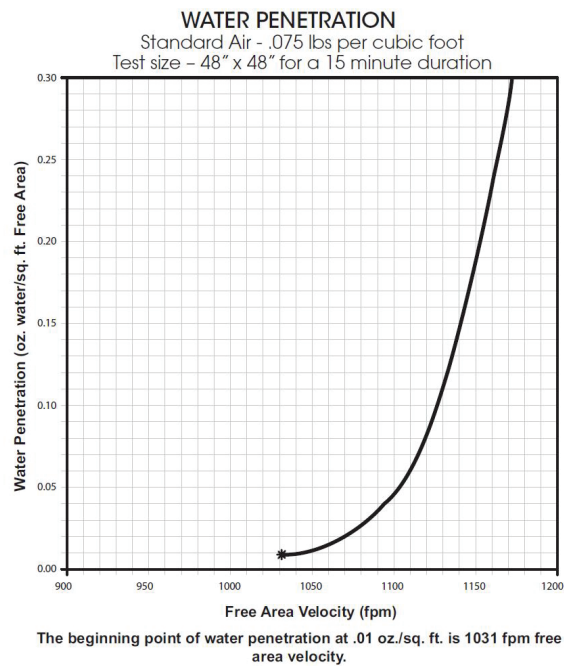
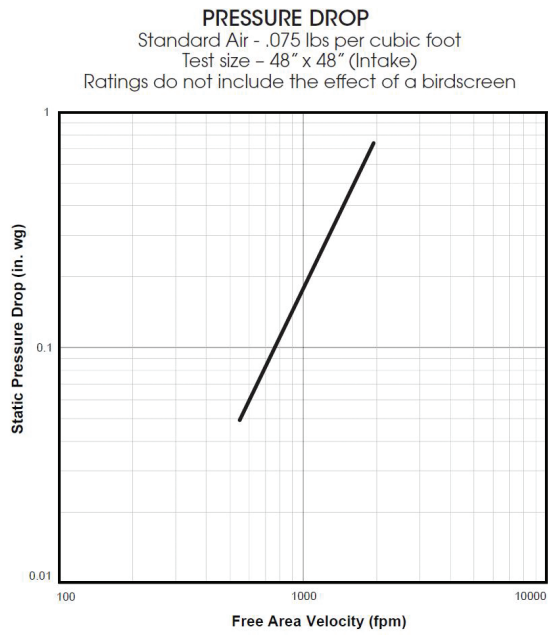

S&P USA certifies that the Model DFL was tested according to AMCA Standard 500. These tests were performed under certain sets of laboratory conditions. These performance ratings do not guarantee that other environmental conditions may actually occur. Use safety factors when selecting louver sizes based upon performance.

*Please refer to the General Catalog or contact the Factory for our Full Line of products available on standard shipping schedules.*

# EXTRUDED ALUMINUM COMBINATION LOUVER/DAMPER MODEL ACL

The Model ACL offers superior resistance to rain and weather while also offering you the ability to completely close the opening off if needed. The channel frame is 4" deep with drainable 45 degree fixed blades in the front with adjustable blades with seals for tight shutoff in the back all within one frame. The adjustable rear blades are operated with a thumb screw. This model is only available in extruded aluminum and comes standard with a birscreen on the interior.

Single panel sizes available: 18" W x 18" H to 48" W x 48" H.



## FEATURES

### Finish

- Mill

### Frame

- 4" deep channel x .080 thick extruded aluminum

### Blades

- Drainable style, .080 thick Extruded Aluminum, positioned at a 45 degree angle and spaced approximately 4" centers.



### Construction

- Screwed

### Birdscreen

- 1/2" Flattened Aluminum in a removable frame mounted on the interior

### Seals

- Extruded TPV

### Linkage

- On-blade type with a Thumb Screw Operator as standard

### Options

- The Model MTR-ACL is an optional 100-240 VAC 50/60 Hz power open spring return motor kit. The adjustable rear blades will return to the closed position in the event of loss of power. The motor kit comes pre-assembled for easy installation.
- 1-1/2" Mounting Flange

△ Contact Support Services at 800-961-7370 or [custserv.jax@solerpalau.com](mailto:custserv.jax@solerpalau.com) for shipping information. Lead-time will vary based on order details and quantity.

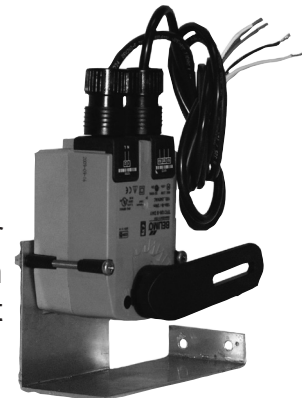

Please refer to the General Catalog or contact the Factory for our Full Line of products available on standard shipping schedules.

# EXTRUDED ALUMINUM COMBINATION LOUVER/DAMPER MODEL ACL

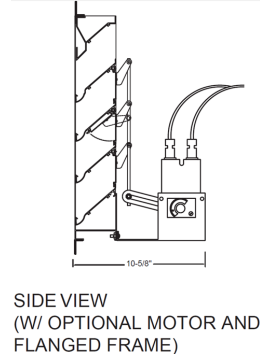
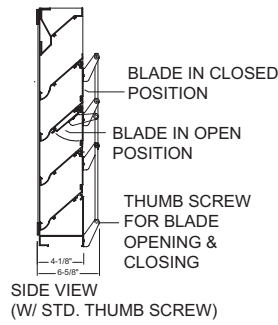
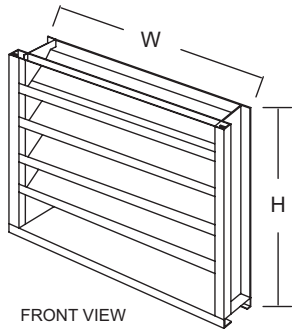

Part No.	Overall Frame Dimensions (W x H) in. inches	Free Area (Sq. ft.)	Est. Shipping Weight (lbs)
ACL18 ♦	17.5 x 17.5	.70	12
ACL24 ♦	23.5 x 23.5	1.49	21
ACL30 ♦	29.5 x 29.5	2.45	29
ACL36 ♦	35.5 x 35.5	3.80	38
ACL48 ♦	47.5 x 47.5	7.22	64

Notes:

- Overall Frame Dimensions have a normal tolerance of .0625".
- Estimated free area calculations are based upon AMCA standard 500-L, actual performance may vary.
- For flanged version of damper, add "-F" to the end of the Part No. Ex: ACL18-F

Ship Schedules:

♦ 10 Day Shipment

**For flanged models,  
contact customer support.**

### PRESSURE DROP

Standard Air - .075 lbs per cubic foot  
Test size - 48" x 48" (Intake)

Ratings do not include the effect of a birdscreen

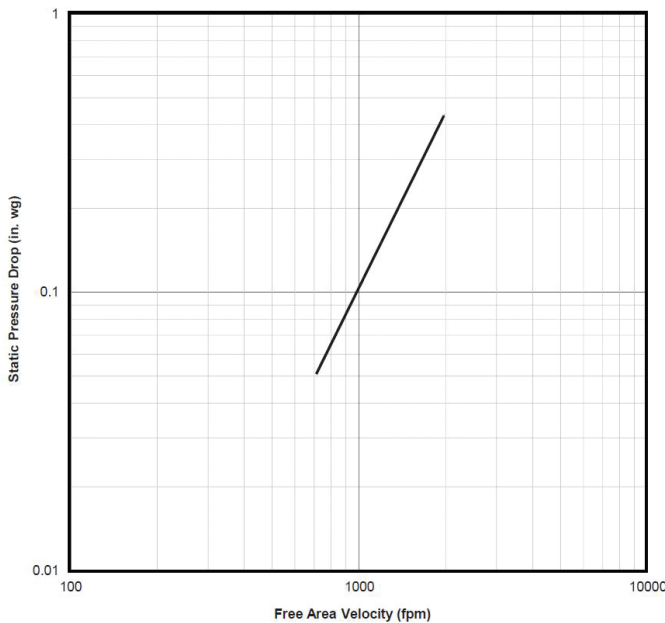

### WATER PENETRATION

Standard Air - .075 lbs per cubic foot  
Test size - 48" x 48" for a 15 minute duration

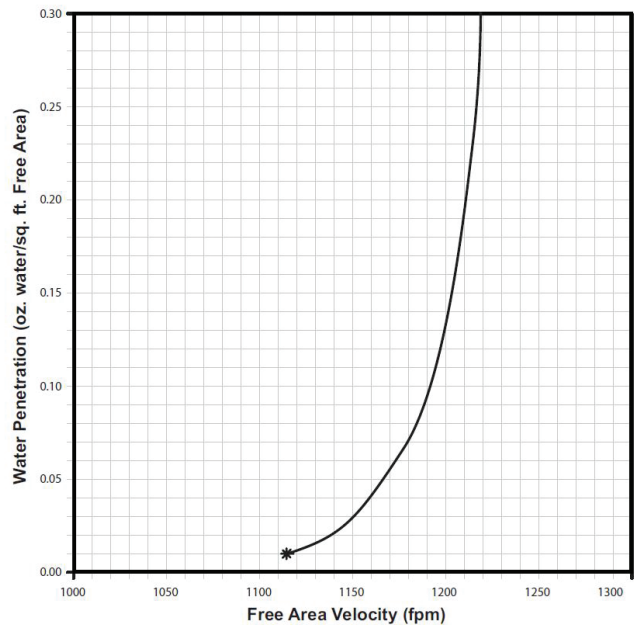

The beginning point of water penetration at .01 oz./sq. ft. is 1118 fpm free area velocity.

S&P USA certifies that the Model ACL was tested according to AMCA Standard 500. These tests were performed under certain sets of laboratory conditions. These performance ratings do not guarantee that other environmental conditions may actually occur. Use safety factors when selecting louver sizes based upon performance.

Please refer to the General Catalog or contact the Factory for our Full Line of products available on standard shipping schedules.



# ALUMINUM DOOR LOUVER MODEL ADL

The Model ADL is a heavy duty door louver. The flanged frame has staked mitered corners for added strength. The blades are inverted V style spaced on approximately 5/8" centers for maximum privacy. The louvers can be used for the transfer of air through any barrier and are ideal for use with 1-3/8" to 2-1/4" thick wood or metal doors. Available in Extruded Aluminum (ADL) comes standard with color matched #8 x 3/4" Phillips head mounting screws. The Model ADL comes standard with a 204-R1 Clear Anodized Finish.



## FEATURES

### Frame

- .040 thick extruded aluminum

### Blades

- Inverted V style, .040 thick extruded aluminum, spaced approximately 5/8" centers

### Construction

- Mitered and staked corners

### Finish

- 204-R1 Clear Anodized

### Fasteners

- #8 x 3/4" Phillips head screws

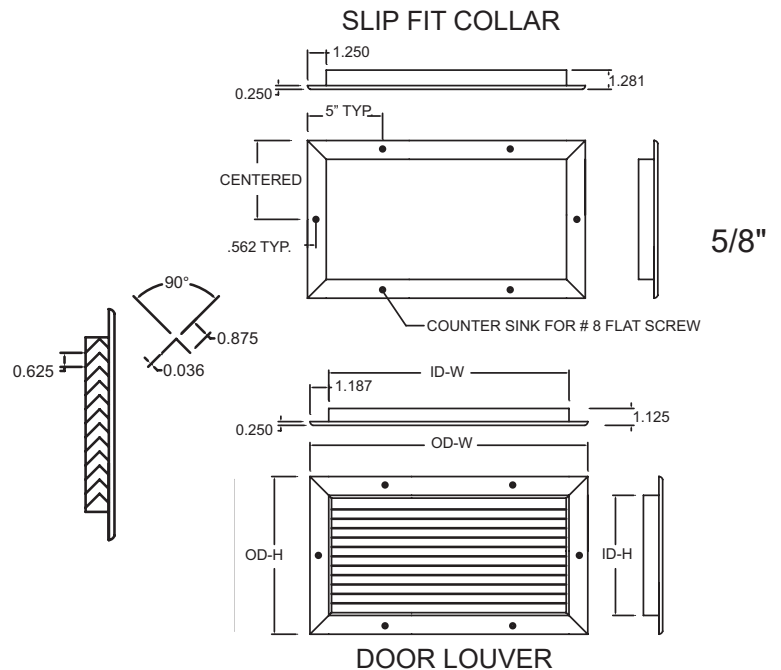

## STANDARD SIZES

### Dimensions in Inches

Part No.	Hole Opening		Actual OD		Est. Shipping Weight (lbs)
	W	H	W	H	
ADL10X4 ♦	10.5	4.5	12.25	6.125	2
ADL12X12 ♦	12.5	12.5	14.25	14.125	4
ADL16X8 ♦	16.5	8.5	18.25	10.125	3.5
ADL16X16 ♦	16.5	16.5	18.25	18.125	5
ADL20X10 ♦	20.5	10.5	22.25	12.125	4.5
ADL20X20 ♦	20.5	20.5	22.25	22.125	7
ADL24X12 ♦	24.5	12.5	26.25	14.125	5.5
ADL24X24 ♦	24.5	24.5	26.25	26.125	9

Ship Schedules:
♦ 10 Day Shipment

Please refer to the General Catalog or contact the Factory for our Full Line of products available on standard shipping schedules.

# STEEL DOOR LOUVER MODEL SDL

The Model SDL is a heavy duty door louver. The flanged frame has welded mitered corners for added strength. The blades are inverted V style spaced on approximately 5/8" centers for maximum privacy. The louvers can be used for the transfer of air through any barrier and are ideal for use with 1-3/8" to 2-1/4" thick wood or metal doors. Available Painted Steel (SDL) and comes standard with color matched #8 x 3/4" Phillips head mounting screws. The Model SDL comes standard with a gray powder coated finish.



## FEATURES

### Frame

- 20 gauge cold rolled steel

### Blades

- Inverted V style, 24 gauge cold rolled steel, spaced approximately 5/8" centers

### Construction

- Mitered and welded corners

### Finish

- Gray powder coated

### Fasteners

- #8 x 3/4" Phillips head screws

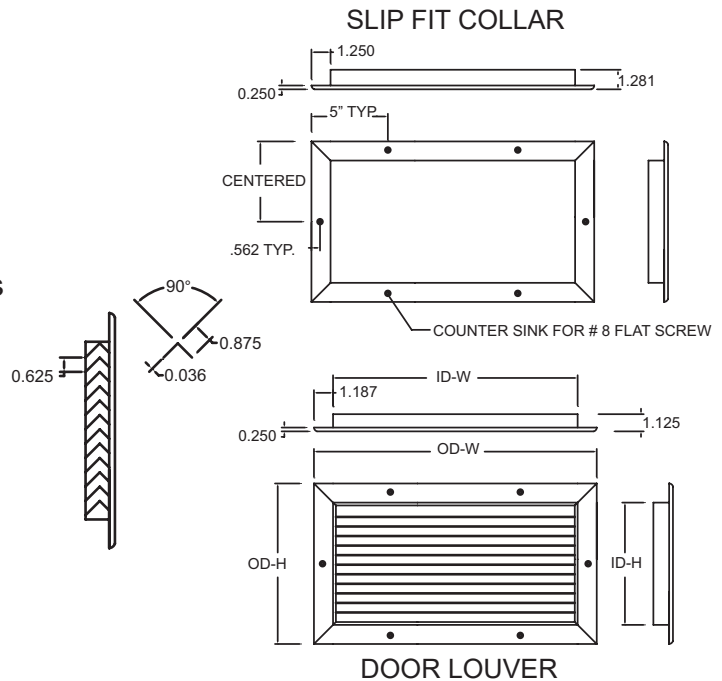

## STANDARD SIZES

### Dimensions in Inches

Part No.	Hole Opening		Actual OD		Est. Shipping Weight (lbs)
	W	H	W	H	
SDL10X4 <sup>△</sup>	10.5	4.5	12.25	6.125	3
SDL12X12 <sup>△</sup>	12.5	12.5	14.25	14.125	6
SDL16X8 <sup>△</sup>	16.5	8.5	18.25	10.125	5
SDL16X16 <sup>△</sup>	16.5	16.5	18.25	18.125	7.5
SDL20X10 <sup>△</sup>	20.5	10.5	22.25	12.125	6.5
SDL20X20 <sup>△</sup>	20.5	20.5	22.25	22.125	10.5
SDL24X12 <sup>△</sup>	24.5	12.5	26.25	14.125	8
SDL24X24 <sup>△</sup>	24.5	24.5	26.25	26.125	13.5

<sup>△</sup> Contact Support Services at 800-961-7370 or [custserv.jax@solerpalau.com](mailto:custserv.jax@solerpalau.com) for shipping information. Lead-time will vary based on order details and quantity.

Please refer to the General Catalog or contact the Factory for our Full Line of products available on standard shipping schedules.

## Competitors Cross Reference Models

Models are for general similarity only. Refer to specifications and construction data for details

S&P	DESCRIPTION	ACME	CARNES	COOK	GREENHECK	PENN	TWIN CITY	COOLAIR	FANTECH	CAPTIVE AIRE
SDB	Power Roof Exhauster - Centrifugal - Belt Drive	PV/PNN	VEBK	ACEB	GB	DXB/KB/JB/MB	BCRD	CRBCA	5BDD	DD-FA
LPD	Power Roof Exhauster - Centrifugal - Direct Drive	PRN	VEDK	ACED	G	DX	CRDD	CRDA	5DDD	DR-HFA
SDBD	Power Roof Exhauster - Centrifugal - Direct Drive	PRN	VEDK	ACED	G	DX	CRDD	CRDA	5DDD	DR-HFA
STXB	Upblast Roof Exhauster - Centrif. - Belt Drive	PNU/PU/PUH	VUBK	ACRUB	CUBE	FXB/FMX	BCRU	UBCA	5BDU	NCA-FA
STXB (UL-762)	Upblast Restaurant Hood Exhauster - Belt Drive	PNU-RG	VRBK	VCR	CUBE	FXBFT/FMBFT	BCRUR	CUBA	5BDU-762	NCA-HPFA
STXD	Upblast Roof Exhauster - Centrif. - Direct Drive	PDU	VUDK	ACRUD	CUE	FX/FMX	DCRU	UDCA	5DDU	DU-HFA
CWD	Sidewall Centrifugal Exhaust- Direct Drive	PW	VWVK	ACWD	GW	WX/WA/WB	TCWX	CWDA	5DDW	-
AF/FF/FFC	Bathroom Fans & Cabinet Fans	V/VQ	VCDD	GEMINI-GC/GN	SP/CSP	ZEPHYR-Z	T/TL	CF/CFL	-	CFA-CA
KSFV	Filtered Fresh Air Supply Roof Fan	AFSI	VSBB	KSPB	KSU/RSF	MU	BCFS	CSF/SIS	5FSU	A-SERIES
ARE/ARS	Dome Axial Power Roof Exhaust/Supply	LQ	LEDA	AQD	AS	DAE	-	SASD/SAED	5ADE/5ADS	DDAR-FA
GED	Sidewall Propeller Fan - Direct Drive	FQ/FN	LTDK/LZDK	APD/SWD	SE/SSI	P	TCPE	CDC	-	CEPRSM
LCE/LCS	Sidewall Propeller Fan - Belt Drive	DC/DCK	LWBA/LWBK	XML/SWB	SBE/S 1&2	BLL/BFM/BBK	WPMB	C-SERIES	1RHR/1RHS	-
SQB	Inline Duct Fan - Centrifugal - Belt Drive	XB	VIBK	SQN-B/SQI-B	BSQ	SXB	BST	SQBA	-	ISQB
SQD	Inline Duct Fan - Centrifugal - Direct Drive	XD	VIDK	SQN-D/SQI-D	SQ	SX	DSI	SQDA	-	-
RXXII	Non-powered Roof Vent - Round Dome	LQV	GSA	PR	GRS	DR	GRV	ARVE	-	-
CM	Belt Driven Utility Vent Set	QBR	VBRA/VFBA	CPRD/CPFEB	SFD/SFB/SWD	D	BCV	-	-	-

# Also Available from S&P

## Residential/Light Commercial

### MODEL TD



Sizes 100 to 400  
100 to 3127 CFM  
Static pressure to 1"  
AMCA Seal for Air  
cULus Listed  
HVI Certified  
ENERGY STAR® Qualified\*  
In-Stock Availability

### MODEL TD-SILENT



Sizes 125X to 200  
100 to 530 CFM  
Static pressure to 1"  
cULus Listed  
HVI Certified  
ENERGY STAR® Qualified  
In-Stock Availability

### MODEL PV



Sizes 100 to 315  
100 to 943 CFM  
Static pressure to 1-1/2"  
AMCA Seal for Air  
cULus Listed  
HVI Certified  
In-Stock Availability

### MODEL SWF



Sizes 100 to 200  
100 to 400 CFM  
Static pressure to 1-1/2"  
cULus Listed  
HVI Certified  
In-Stock Availability

### MODEL PC



#### PC Model Options:

PC - AC Motors  
PCD - DC Motors  
PCV - Values Series  
PCLP - Low Profile  
PCRL - Recessed Vent Lights



Sizes 50 to 150  
50 to 150 CFM  
Static pressure to 1"  
HVI Certified  
AMCA Air & Sound Certified  
cETLus Listed  
ENERGY STAR® Qualified  
Lighted & Motion Sensor Grilles

### MODEL TR (ERV)



Sizes 90 to 300  
40 to 310 CFM  
Static pressure to 1"  
cULus Listed  
HVI Certified  
In-Stock Availability

### MODEL reFresh



Sizes 8 and 10  
AC and EC Motors  
Static pressure to 0.4"  
HVI Certified  
AMCA Seal for Air & Sound  
cULus 705 Listed  
ENERGY STAR® Qualified  
Ecowatt



S&P USA Ventilation Systems, LLC

6393 Powers Avenue  
Jacksonville, FL 32217  
T. 904-731-4711 • F. 904-737-8322  
www.solerpalau-usa.com

S&P Canada Ventilation Products, Inc.

6710 Maritz Drive Unit #7  
Mississauga, ON L5W 0A1 - Canada  
T. 416-744-1217 • F. 416-744-0887  
www.solerpalaucanada.com