



MODELS D

FORWARD CURVED DIRECT DRIVE UTILITY FAN



MODEL FEATURES

- Weather proof drive cover
- Inlet & outlet screens
- Motorized dampers
- Vibration pads
- Discharge damper

MODEL OVERVIEW

The standard “D” Series is used for general ventilation with ducting where ever lower cfm, static and sound are required. The High Speed “D” Series will handle higher static pressure and is used with garage monoxide system and industrial applications. Housing and bases are manufactured with 16 gauge steel and finished with baked powdered polyester paint. The forward curved wheels are dynamically balanced and equipped with cast iron hubs. Open drip proof fan duty motors in common voltages are standard. TEFC, Explosion Proof and other configured motors are available as required.

Direct Drive Blower Performance Data

MODEL NO.	MOTOR HP	BLOWER RPM	FREE AIR		1/8		1/4		3/8		1/2		5/8		3/4		1		1 1/4	
			CFM	OV	CFM	OV	CFM	OV	CFM	OV	CFM	OV	CFM	OV	CFM	OV	CFM	OV	CFM	OV
D5A	1/6	1750	184	1630	169	1500	144	1275	112	995	—	—	—	—	—	—	—	—	—	—
D6AA	1/6	1150	390	1880	330	1590	250	1205	100	480	—	—	—	—	—	—	—	—	—	—
D6AB	1/6	1750	595	2865	560	2700	515	2480	470	2265	420	2025	365	1760	300	1445	—	—	—	—
D8A	1/6	1150	760	2570	680	2300	620	2095	535	1810	430	1455	—	—	—	—	—	—	—	—
D8C	1/2	1750	1150	3885	1085	3665	1050	3550	1005	3400	960	3240	915	3090	865	2920	750	2535	580	1960
D9A	1/6	850	875	1870	835	1785	780	1665	680	1450	470	1005	—	—	—	—	—	—	—	—
D9C	1/3	1150	1180	2520	1160	2480	1125	2400	1090	2325	1035	2210	963	2060	855	1825	—	—	—	—
D11D	1/2	850	1520	2395	1380	2170	1290	2025	1145	1800	1010	1585	860	1350	—	—	—	—	—	—
D11E	3/4	1150	2060	3240	1970	3095	1870	2940	1800	2830	1710	2690	1605	2525	1500	2355	1290	2030	1020	1605
D12E	3/4	850	2475	2885	2365	2760	2260	2640	2140	2495	2015	2350	1885	2200	1725	2010	1245	1450	—	—
D12H	2	1150	3350	3900	3275	3815	3195	3725	3115	3630	3025	3530	2940	3430	2850	3320	2660	3100	2450	2855

High Speed Blower Performance Data

MODEL NO.	MOTOR HP	BLOWER RPM	1/2		3/4		1		1 1/4		1 1/2		1 3/4		2		2 1/4		2 1/2		2 3/4		
			CFM	OV	CFM	OV	CFM	OV	CFM	OV	CFM	OV	CFM	OV	CFM	OV	CFM	OV	CFM	OV	CFM	OV	
D9D	1/2	1750	WILL OVERLOAD MOTOR				895	1910	810	1730	735	1570	615	1315	—	—	—	—	—	—	—	—	
D9E	3/4	1150	WILL OVERLOAD MOTOR				—	—	1550	3310	1445	3085	1290	2755	1100	2345	—	—	—	—	—	—	
D9F	1	1750	1720	3670	1675	3580	1620	3460	1550	3310	1445	3085	1290	2755	1100	2345	—	—	—	—	—	—	
D11F	1	1150	WILL OVERLOAD MOTOR									1425	3070	1280	2760	1120	2415	910	1960	—	—		
D11G	1 1/2	1750	WILL OVERLOAD MOTOR									1840	3970	1730	3730	1600	3455	1450	3130	1280	2760	1040	2240
D11H	2	1750	WILL OVERLOAD MOTOR									2415	3795	2240	3520	2130	2910	1660	2610	3345	1990	3130	1850



Direct Drive Blowers - Arrangement #4

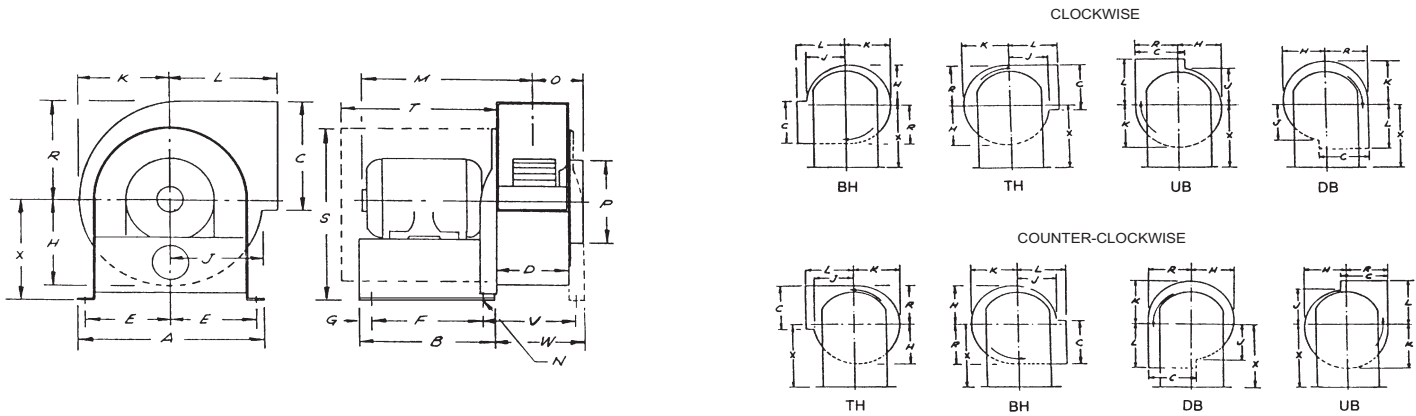

Direct Drive Blower Dimensions

MODEL NO.	WHEEL	A	B	C	D	E	F	G	H	J	K	L	M*	N	O	P	R	S	T	V	W	X	MAX MOTOR FRAME
D5A	4 1/2 x 2 1/2	8 3/8	7	5 1/8	3 3/8	3 3/4	6	1/2	3 1/2	3 1/8	3 3/4	4 1/8	11 1/2	3/8	2 3/4	4	4 5/8	8 5/8	9 1/2	—	—	5 1/4	48
D5A	4 3/4 x 2 1/4	8 3/8	7	5 1/8	3 3/8	3 3/4	6	1/2	3 1/2	3 1/8	3 3/4	4 1/8	11 1/4	3/8	2 3/4	4	4 5/8	9 1/8	9 1/2	—	—	5 3/4	56
D6AA D6AB	6 1/4 x 3	9 3/8	8	7 3/8	4 1/4	4 1/4	7 1/2	1/2	5	4	6	5	11 7/8	3/8	3 1/8	6	7 1/8	12 3/8	12	—	—	8 1/2	48
D6AA D6AB	6 1/4 x 3	9 3/8	8	7 3/8	4 1/4	4 1/4	7 1/2	1/2	5	4	6	5	11 5/8	3/8	3 1/8	6	7 1/8	12 7/8	12	—	—	9	56
D8A D8C	7 3/4 x 3 7/8	11	8	8 1/4	5 3/8	5	7	1/2	6	4 5/8	6 3/4	6 7/8	12 1/2	3/8	3 3/4	8	8	13 1/8	12	—	—	8 1/2	48
D8A D8C	7 3/4 x 3 7/8	11	8	8 1/4	5 3/8	5	7	1/2	6	4 5/8	6 3/4	6 7/8	12 1/4	3/8	3 3/4	8	8	13 5/8	12	—	—	9	56
D9A D9C	9 x 4 1/2	12 1/8	8	10 3/4	6 1/2	5 5/8	7	1/2	6 3/4	5 5/8	7 3/4	7 1/8	13 1/4	3/8	4 3/8	9	9 1/4	14 1/2	16	—	—	9 3/8	48
D9A D9C	9 x 4 1/2	12 1/8	8	10 3/4	6 1/2	5 5/8	7	1/2	6 3/4	5 5/8	7 3/4	7 1/8	13	3/8	4 3/8	9	9 1/4	15	16	—	—	9 7/8	56
D11D D11E	10 5/8 x 5 1/4	14 3/4	9	11 3/4	8	6 7/8	7 1/2	3/4	8	6 3/4	9 1/8	8 1/8	13 7/8	3/8	5	10	10 3/4	18 1/4	16	—	—	11 3/4	56/145T
D11D D11E	10 5/8 x 5 1/4	14 3/4	11 1/2	11 3/4	8	6 7/8	10	3/4	8	6 3/4	9 1/8	8 1/8	15 1/2	3/8	5	10	10 3/4	17 3/4	16	—	—	11 3/4	182T/ 184T
D12D D12E D12H	12 1/2 x 6 1/2	16 3/8	13	13 1/4	9 5/8	7 3/8	9 3/4	2 1/2	10 1/8	8 1/2	11 1/2	10 1/2	16 3/8	9/16	6 1/2	13 1/4	13 1/4	24 1/4	20	11 1/4	11 1/4	17	182T/ 184T
D12D D12E D12H	12 1/2 x 6 1/2	16 3/8	13	13 1/4	9 5/8	7 3/8	9 3/4	2 1/2	10 1/8	8 1/2	11 1/2	10 1/2	20 3/4	9/16	6 1/2	13 1/4	13 1/4	24 1/4	20	11 1/4	11 1/4	17	213T/ 215T

* "M" dimension will vary on type of motor used

High Speed Blower Dimensions

MODEL	HP	RPM	WHEEL	A	B	C	D	E	F	G	H	J	K	L	M*	N	O	P	R	X	MAX MOTOR FRAME
D9D	1/2	1750	9 x 3	12 1/8	8	10 3/4	6 1/2	5 5/8	7	1/2	6 3/4	5 5/8	7 3/4	7 1/8	13	3/8	4 3/8	9	9 1/4	9 7/8	56
D9E	3/4	1750	9 x 4 1/2	12 1/8	8	10 3/4	6 1/2	5 5/8	17	1/2	6 3/4	5 5/8	7 3/4	7 1/8	13	3/8	4 3/8	9	9 1/4	9 7/8	56
D9F	1	1750	9 x 4 1/2	12 1/8	8	10 3/4	6 1/2	5 5/8	7	1/2	6 3/4	5 5/8	7 3/4	7 1/8	14 1/4	3/8	4 3/8	9	9 1/4	9 7/8	56/145T
D9F	1	1750	9 x 4 1/2	12 1/8	11	10 3/4	6 1/2	5 5/8	10	1/2	6 3/4	5 5/8	7 3/4	7 1/8	15	3/8	4 3/8	9	9 1/4	10 7/8	182/184T
D11F	1	1750	10 5/8 x 3	14 3/4	9	11 3/4	5 7/8	6 7/8	7 1/2	3/4	8	6 3/4	9 1/8	8 1/8	12 3/4	3/8	4	10	10 3/4	11 1/4	56/145T
D11F	1	1750	10 5/8 x 3	14 3/4	11 1/2	11 3/4	5 7/8	6 7/8	10	3/4	8	6 3/4	9 1/8	8 1/8	14 5/8	3/8	4	10	10 3/4	11 1/4	182/184T
D11G	1 1/2	1750	10 5/8 x 4	14 3/4	9	11 3/4	5 7/8	6 7/8	7 1/2	3/4	8	6 3/4	9 1/8	8 1/8	12 3/4	3/8	4	10	10 3/4	11 1/4	56/145T
D11G	1 1/2	1750	10 5/8 x 4	14 3/4	11 1/2	11 3/4	5 7/8	6 7/8	10	3/4	8	6 3/4	9 1/8	8 1/8	14 5/8	3/8	4	10	10 3/4	11 1/4	182/184T
D11H	2	1750	10 5/8 x 5 1/4	14 3/4	9	11 3/4	8	6 7/8	7 1/2	3/4	8	6 3/4	9 1/8	8 1/8	13 7/8	3/8	5	10	10 3/4	11 1/4	56/145T
D11H	2	1750	10 5/8 x 5 1/4	14 3/4	11 1/2	11 3/4	8	6 7/8	10	3/4	8	6 3/4	9 1/8	8 1/8	15 1/2	3/8	5	10	10 3/4	11 1/4	182/184T

* "M" dimension will vary on type of motor used