



# MDX-ES24VK

Installation, Operation and Maintenance Manual



## READ AND SAVE THESE INSTRUCTIONS

The purpose of this manual is to aid in the proper installation and operation of fans manufactured by S&P. These instructions are intended to supplement good general practices and are not intended to cover detailed instruction procedures, because of the wide variety and types of fans manufactured by S&P.



## WARNINGS

READ AND SAVE THESE INSTRUCTIONS. FAILURE TO COMPLY WITH INSTRUCTIONS COULD RESULT IN PERSONAL INJURY AND/OR PROPERTY DAMAGE!

### CAUTION:

1. For General Ventilating Use Only. Do Not Use To Exhaust Hazardous Or Explosive Materials And Vapors
2. The MDX-ES24VK is suitable for operation within indoor environments only.

**WARNING: TO REDUCE THE RISK OF FIRE, ELECTRIC SHOCK OR INJURY, OBSERVE THE FOLLOWING:**

1. Use this unit only in the manner intended by the manufacturer. If you have questions, contact the manufacturer.
2. Before servicing or cleaning unit, switch power off at service panel and lock the service disconnecting means to prevent power from being switched on accidentally. When the service disconnecting means cannot be locked, securely fasten a prominent warning device, such as a tag, to the service panel.
3. Installation work and electrical wiring must be done by qualified person(s) in accordance with all applicable codes and standards, including fire-rated construction.
4. Sufficient air is needed for proper combustion and exhausting of gases through the flue (chimney) of fuel burning equipment to prevent back drafting. Follow the heating equipment manufacturer's guideline and safety standards such as those published by the National Fire Protection Association (NFPA), and the American Society for Heating, Refrigeration and Air Conditioning Engineers (ASHRAE), and the local code authorities.
5. When cutting or drilling into wall or ceiling, do not damage electrical wiring and other hidden utilities.
6. Ducted fans must always be vented to the outdoors.

## PRE-INSTALLATION INSPECTION

The MDX-ES24VK has been manufactured in accordance with rigorous standards of production. All the components have been checked and tested at the end of the manufacturing process. We recommend that you check the following after receiving this product:

1. The correct size has been received.
2. The correct model has been received.
3. The details on the rating label correspond to the electrical supply: voltage, frequency etc.

Remove the unit from packaging and inspect for shipping damage within 5 days of receipt. If the product is found to be damaged, immediately contact your local authorized supplier. **DO NOT OPERATE THE UNIT IF DAMAGED.** These instructions should be considered as a supplement to EPA standard practices, as well as all state and local building code regulations.

Before installing the product check the following points:

1. The damper blade opens and closes freely.
2. There are no obstructions to the airflow.

## ENVIRONMENT

The MDX-ES24VK is suitable for operation within indoor environments only. The MDX-ES24VK is suitable for the supply of both conditioned and un-conditioned airstreams within the temperature ranges (inclusive of duct airstream's temperature) of -40°C up to +60°C.

## MOUNTING

Choose a mounting location which allows convenient wiring and maintenance accessibility. The MDX-ES24VK can be mounted in any orientation, horizontal or vertical, and is suitable for supply/fresh air applications. The motorized damper will be installed between the fresh air wall cap/roof cap/soffit vent (with insect screen) and the HVAC unit return duct. The ES24V fresh air control can be mounted:

- On the insulated ductwork between the wall cap and the motorized damper, or (Note, the 24V power wires (R & C) will need to be extended from the HVAC unit power supply or a separate 120V-24V transformer)
- On the HVAC unit (Note, the temperature (26AWG cable) and humidity (6P6C phone cable) sensor wires will need to be extended.)

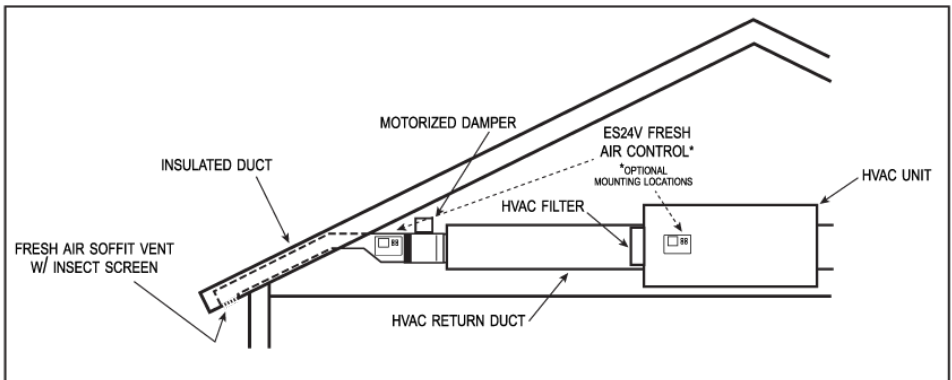
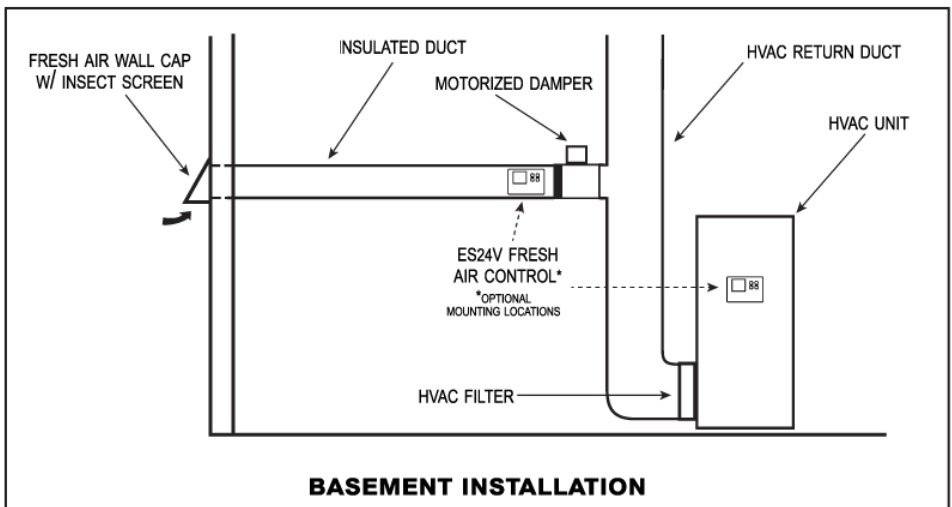

Make sure the temperature and humidity sensors are installed into the insulated fresh air duct between the wall cap and motorized damper if necessary.

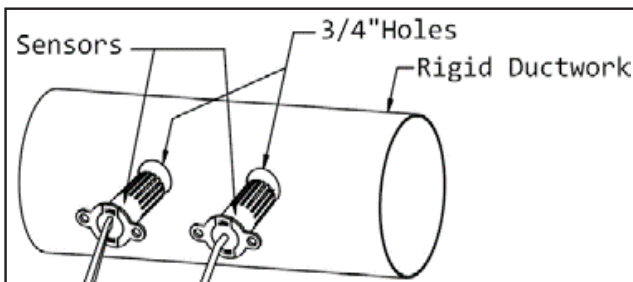

## DUCTING

All ducting and fresh air intake construction/location must comply with local and national building codes. Do not locate fresh air intakes near contaminant sources (ex: dryer exhaust vent, garbage, etc). Connect the ductwork to the wall cap and HVAC return duct with screws, cable ties, worm clamps, and rated tape as necessary. Ensure that the ductwork is properly connected to a properly sized, low restriction fresh air intake with weather hood and insect screen.

S&P recommends round insulated rigid ductwork for best air and sound performance. Round flexible ductwork is acceptable, but ensure that it is pulled tight to reduce losses. Keep the length of duct and number of elbows to a minimum for best air and sound performance. Insulated ductwork will minimize building heat loss/gain and reduce the potential for condensation.

The ducting from the HVAC unit fan to the outside of the building has a strong effect on the air flow, noise and energy use of the fan. Use the shortest, straightest duct routing possible for best performance, and avoid installing smaller ducts than recommended. Insulation around the ducts can reduce energy loss and inhibit mold growth.

Ductwork connections and penetrations should be sealed with duct tape, duct fast-clamps, or caulk (available through your local distributor) to create an air-tight path from the building exterior to the ventilated space.

## WIRING

**CAUTION:** Ensure that power is turned off and locked out before making any wiring connections.

The MDX-ES24VK operates from a standard 24V 60Hz AC electrical supply. There are multiple wiring scenarios available depending on the installer preferences. The diagrams below show 3 common scenarios where the ES24V is connected either directly to the HVAC unit transformer or an auxiliary transformer and the MD is connected either directly to the ES24V damper terminals or to the ES24V damper terminals through a SPST, N.O. 24V relay and transformer. This will depend on the VA available from the HVAC unit transformer. S&P recommends 20VA be available to operate the motorized damper. If 20VA is not available from the HVAC unit transformer, then an auxiliary transformer to power the ES24V and motorized damper is recommended (transformers and relays provided by others).

All wiring must be carried out by a qualified electrician in accordance with National Electrical Code and all applicable state and local buildings codes. Electrical connections should be made in accordance with the following **Figures: 1-3**

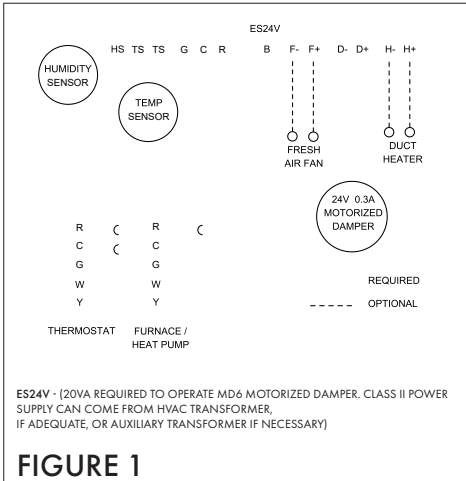

FIGURE 1

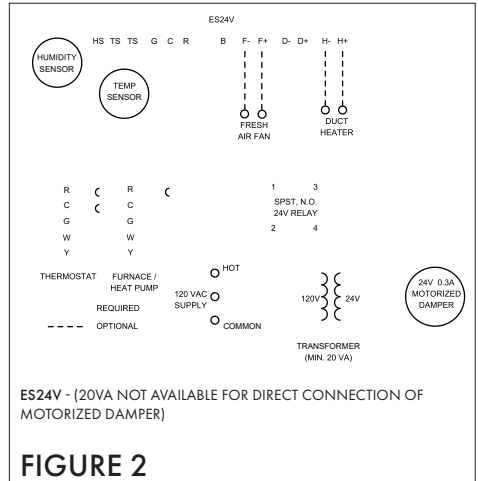
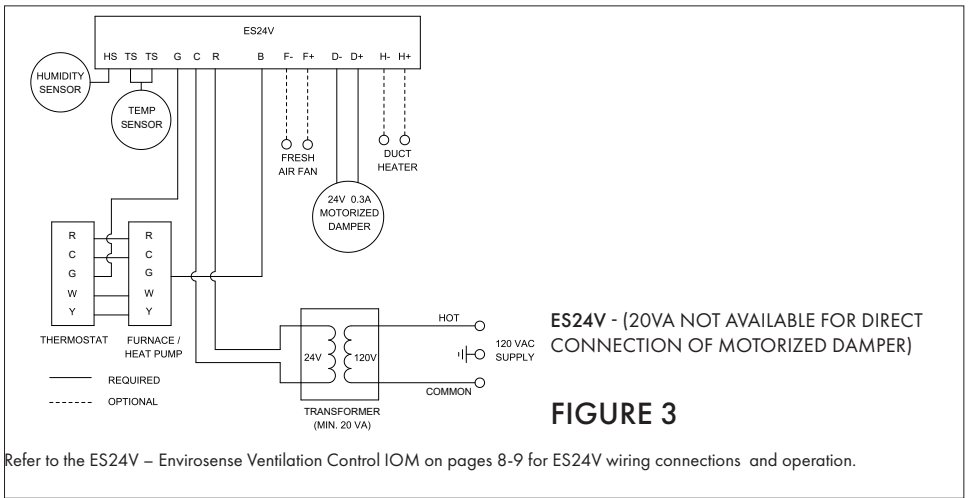

FIGURE 2



## AIRFLOW SETTING

**CAUTION:** Refer to local and national Ventilation and Indoor Air Quality standards to ensure the proper airflow rate.

Ensure the HVAC unit air filter is clean and installed. Turn the ES24V to the “ON” position and wait approximately 10 seconds for the HVAC unit fan to turn on and the motorized damper to open. (Note, ensure that the Motorized Damper is enabled on the ES24V; refer to ES24V IOM on page 6-7). Using a manometer or anemometer, measure and record the airflow through the fresh air duct (refer to the measuring device instructions and the airflow/air velocity table on page 5. Keep in mind, lower velocities are preferred to decrease noise and increase filter effectivity). Once complete, turn the ES24V to the “OFF” position and calculate the required continuous CFM based on the ventilation code.

ASHRAE 62.2-2010

$$\text{Required Continuous CFM} = ((0.01 * \text{Floor Area in ft}^2) + 7.5(\# \text{ of bedrooms} + 1))$$

Example:

2,000 square foot dwelling

3 bedrooms

= **50 CFM continuous**

ASHRAE 62.2-2013 & 2016

$$\text{Required Continuous CFM} = ((0.03 * \text{Floor Area in ft}^2) + 7.5(\# \text{ of bedrooms} + 1))$$

Example:

2,000 square foot dwelling

3 bedrooms

= **90 CFM continuous**

Now that the required continuous CFM is known, calculate the required run time / hour.

$$\text{Run Time / Hour} = 60 * (\text{Required Continuous CFM} / \text{Actual Measured CFM})$$

Example (based on ASHRAE 62.2-2010 example above):

50 Required Continuous CFM

150 Actual Measured CFM

= **20 minutes / hour**

Set the ES24V to the correct Run Time / Hour and High / Low Temperature & Humidity limits per the ES24V IOM on pages 6-7.

Airflow / Air Velocity Reference Table				
Airflow (CFM)	Duct Size (in)			
	4	5	6	8
	Air Velocity (FPM)			
30	344	220	153	86
40	458	293	204	115
50	573	367	255	143
60	688	440	306	172
70	802	513	357	201
80	917	587	407	229
90	1031	660	458	258
100	1146	733	509	286
110	1261	807	560	315
120	1375	880	611	344
130	1490	953	662	372
140	1604	1027	713	401
150	1719	1100	764	430
160	1833	1173	815	458
170	1948	1247	866	487
180	2063	1320	917	516
190	2177	1393	968	544
200	2292	1467	1019	573

Note, if the Actual Measured CFM is not enough, the installer may need to increase the duct size or add a booster fan if necessary. Ensure there is no blockage in the ductwork first.

## MAINTENANCE

**CAUTION: BEFORE CARRYING OUT ANY MAINTENANCE OR SERVICING, ENSURE THE UNIT IS DISCONNECTED FROM THE MAIN ELECTRICAL SUPPLY.**

S&P recommends inspection of the Motorized Damper and ES24V at least once every twelve (12) months. To inspect the unit disconnect from electrical supply. Remove the motorized damper from the fresh air ductwork and inspect the damper blade for damage and proper function. If any debris is evident on the damper blade clean with a damp (not wet) cloth. DO NOT USE any detergents or abrasive materials for cleaning. Reinstall motorized damper to the fresh air ductwork and reseal joints.

## WARRANTY

S&P USA - S&P Canada warrant that the MDX-ES24VK will be free from defective materials and workmanship for the period of (5) years from the date of original purchase. In the event that we find any part is defective the product will be repaired or, in the Company's discretion, replaced without charge provided that the product has been installed in accordance with the enclosed instructions and all applicable EPA Standards and state and local building codes. an such as: Improper Maintenance; Misuse; Negligence; Alteration; Abuse; Abnormal Use; or Accident or Incorrect Electrical Voltage and Current.

Please visit [SolerPalau-USA.com/sp-form/claims.html](http://SolerPalau-USA.com/sp-form/claims.html) for additional details about warranty procedures.



**S&P USA Ventilation Systems, LLC**  
**6933 Powers Ave**  
**Jacksonville, FL 32217**  
**ES24V**

### EnviroSense Ventilation Controller

The ES24V controls a ventilator to meet fresh air supply requirements while limiting operation during periods of extreme temperature and/or humidity.

#### INSTALLATION & OPERATION MANUAL

- CAUTION:**  
**READ AND SAVE THESE INSTRUCTIONS.**
- Before installation or maintenance, disconnect the power supply.
  - This control is for 24 VAC applications only.
  - All wiring must be done by qualified person(s) in accordance with all applicable codes & standards.
  - Indoor Use Only

#### WIRING

Use Copper Conductors Only

Terminal	Type	Description
R	24VAC	Input: 24VAC Input (50/60 Hz)
C	24VAC	Input: 24VAC common
G	24VAC	Input: Furnace Blower (Optional)
B	24VAC	Output: Furnace Blower (2A max) (Optional)
F+	24VAC	Output: Fresh Air Fan output + (2A max)
F-	24VAC	Output: Fresh Air Fan output - (2A max)
D+	24VAC	Output: Motorized Damper + (2A max) (Optional)
D-	24VAC	Output: Motorized Damper - (2A max) (Optional)
H+	24VAC	Output: Duct Heater output + (2A max) (Optional)
H-	24VAC	Output: Duct Heater output - (2A max) (Optional)

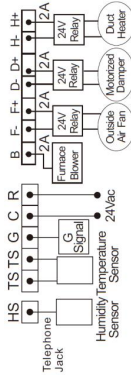

#### MOUNTING

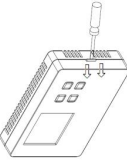

**Front Cover Removal**  
 Insert a flathead screwdriver into the slot on the right side of the controller, and apply gentle pressure inward and up so that the front cover disengages from the back cover. Pull the front cover up and to the left.

#### Back Cover Mounting

Locate the control on the mounting surface being sure to allow clearance for the necessary wiring connections. Mark the mounting hole locations and remove the back cover from the work space. Make the stripped/labelled wiring connections now. **CAUTION: Be sure that no exposed portions of wires are touching.**

If installing onto wood, mount the back cover with the provided screws. If installing onto drywall, drill pilot holes using a #732 drill bit (not provided) and tap provided drywall anchors into place. Mount with provided screws. **NOTE: Velcro can be used to mount the control instead of screws if necessary.**

Verify that wiring connections are correct and secure.

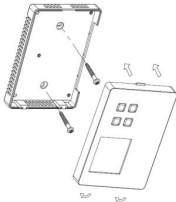

Align the front cover with the back cover starting on the left side. Push the front cover towards the back cover in a "hinging" motion from the left to the right. **CAUTION: Make sure the front cover is aligned properly with the back cover to avoid damaging the control.** Press down until the front cover snaps securely into place.

#### Sensor Mounting

The ES24V comes with a temperature sensor (26AWG, 2 wire) and humidity sensor (6PFC, telephone wire), both 10" long, install the sensors at a location so that they will be exposed to the fresh air intake (ex: the fresh air ductwork). Drill 2, 3/4" diameter holes, spaced appropriately and install the sensors with the provided hardware. **NOTE: the sensor wires can be extended up to 300 feet without deviation.** Use appropriate duct tape to seal joints/openings as necessary.

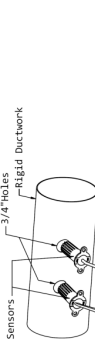

#### DIMENSIONS (in)

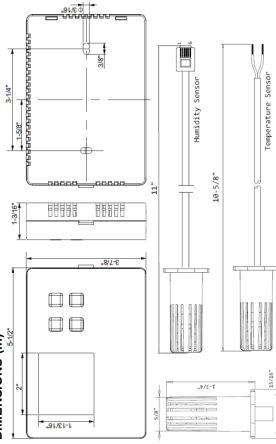

#### SCREEN DIAGRAM

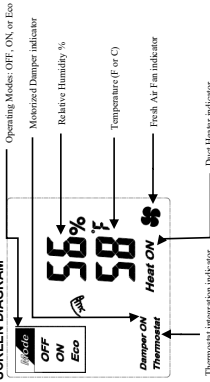

#### OPERATING MODES

**OFF Mode:** All outputs are off.  
**ON Mode:** The Fresh Air Fan, Motorized Damper (if enabled), and Furnace Blower (if enabled) are on continuously. The Duct Heater will follow the user settings (see FUNCTION SETTINGS below).  
**Eco Mode:** Eco Mode limits the Fresh Air Fan operation during periods of extreme temperature and/or humidity. The Fresh Air Fan, Motorized Damper (when enabled), Furnace Blower (when enabled), and Duct Heater (when enabled) will follow the user settings when the outside air temperature/humidity is within the user set limits (see FUNCTION SETTINGS below).

The Fresh Air Fan will run for the user set amount of time/hour while the temperature/humidity limits are within range. The temperature/humidity sensors evaluate the fresh air conditions every 10 seconds. While the fresh air temperature/humidity is within the user set limits, the Fresh Air Fan/accessories will run per the user settings. When the fresh air temperature/humidity exceeds the user set limits, the Fresh Air Fan/accessories will turn off and engage a timer. The timer will run the fan for 5 minutes every 15 minutes in order to meet code requirements. **NOTE: the Furnace Blower (if enabled) will not run during this check procedure to prevent cycling.** The fan will continue this check procedure until the temperature/humidity limits are within the user set limits.

#### If Enabled (in SETUP):

The Furnace Blower will be on any time there is a call from "C" Input or any time the Fresh Air Fan is on (excluding the check procedure above).  
 The Motorized Damper will be on anytime the Fresh Air Fan is on. The Duct Heater will be on any time the Fresh Air Fan is on and the set point > room temperature +2°F.  
**(Motorized Damper, Furnace Blower, and Duct Heater are required to be enabled in SETUP)**

#### BUTTONS

Keys	Description
Mode	Select the operating mode
Set	Confirm settings
▲	Increase settings
▼	Decrease settings



**SETUP**

Press and hold [MODE] for 3 seconds to enter setup mode.



06 Fan Run Time per Hour (Default: 15 minutes)  
Press [▲/▼] to adjust 5-60 Minutes/Hour (increments of 5).  
Press [SET] to confirm settings and return to normal mode.

All setting screens will return to the normal mode screen automatically after 20 seconds.



01 Optional Duct Heater (Default: heater disabled)  
Press [▲/▼] to enable or disable duct heater.  
Press [SET] to confirm settings.



02 Temperature Unit (Default: degrees F)  
Press [▲/▼] to select degrees C or degrees F.  
Press [SET] to confirm settings.



03 Humidity/Temperature (Default: temperature and humidity)  
Press [▲/▼] to evaluate temperature and humidity  
temperature and humidity.  
Press [SET] to confirm settings.



04 Optional Motorized Damper (Default: motorized damper disabled)  
Press [▲/▼] to enable or disable motorized damper.  
Press [SET] to confirm settings.



05 Optional Thermostat Integration (Default: standalone system)  
Press [▲/▼] to enable or disable thermostat integration.  
Press [SET] to confirm settings.



**FUNCTION SETTINGS**

Press <Set> key to set the temperature/humidity limits and duct heater set point.



Press [▲/▼] to change the high limit temperature setting.  
Press [SET] to confirm settings.



Press [▲/▼] to change the high limit humidity setting.  
Press [SET] to confirm settings.



Press [▲/▼] to change the low limit temperature setting.  
Press [SET] to confirm settings.



Press [▲/▼] to change the low limit humidity setting.  
Press [SET] to confirm settings.



Press [▲/▼] to change the duct heater activation temperature setting.  
Press [SET] to confirm settings and return to normal mode.

**FACTORY RESET**

Press and hold [▲/▼] buttons in OFF mode for ~5 seconds to reset the control to factory settings. will be displayed on the screen when complete.

**FEATURES**

- ◆ Voltage supply: 24VAC +/- 15% 50/60Hz
- ◆ System mode: Off / On / Eco
- ◆ Temperature unit mode: °F or °C
- ◆ Temperature measurement range: 15°F - 130°F (-10°C to 55°C)
- ◆ High Limit Temperature settings range: 65 - 105°F (18°C to 40°C)
- ◆ Low Limit Temperature settings range: 20 - 60°F (-6°C to 16°C)
- ◆ Humidity Temperature settings range: 32°F - 62°F (0°C - 16°C)
- ◆ Temperature resolution: 1°F or 0.5°C
- ◆ Temperature Accuracy: +/- 1°F or 0.5°C
- ◆ Humidity measurement range: 10-95%
- ◆ High Limit Humidity settings range: 55-90%
- ◆ Low Limit Humidity settings range: 10-50%
- ◆ Humidity resolution: 1%
- ◆ Humidity Accuracy: +/- 5%
- ◆ 10 inch RJ11 (6 wires) phone cable for humidity sensor
- ◆ 10 inch 28AWG (2 wires) cable for temperature sensor
- ◆ Max Sensor Wire Length: 300 feet (100m)
- ◆ Motorized Damper relay output (Maximum 2A)
- ◆ Fan relay output (Maximum 2A)
- ◆ Duct Heater relay output (Maximum 2A)
- ◆ Nurmax Blower Output (Maximum 2A)
- ◆ Non-volatile memory to store settings, configuration and user preferences
- ◆ Operate temperature: 15°F to 130°F (-10°C to 55°C)
- ◆ Storage temperature: -20°F to 168°F (-29°C to 70°C)
- ◆ Temperature limit of mounting surface: 130°F (55°C)
- ◆ Terminate: 2.5mm<sup>2</sup> cable
- ◆ Pollution Degree: 2
- ◆ Degree of protection: IP20
- ◆ Electronic control: Type 2.B
- ◆ Class II Control
- ◆ cULUS listed: UL 60730-1
- ◆ Housing Material: Lexan 943(f1), 1.6mm thick, V-0 (UL94 Rating)
- ◆ Time Setting Range: 5-60 Minutes
- ◆ Power: 1.5W (Max)





S&P USA Ventilation Systems, LLC  
6393 Powers Avenue  
Jacksonville, Florida 32217  
T. 904-731-4711 F. 904.737.8322  
[www.solerpalau-usa.com](http://www.solerpalau-usa.com)

S&P Canada Ventilation Products, Inc  
6710 Maritz Drive Unit #7  
Mississauga, ON L5W 0A1 - Canada  
T. 416-744-1217 F. 416-744-0887  
[www.solerpalaucanada.com](http://www.solerpalaucanada.com)