

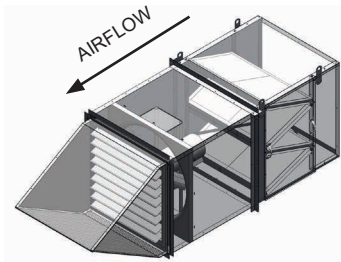

# FILTERED WALL HOUSING SIDEWALL PROPELLER FANS - BELT & DIRECT DRIVE EXHAUST & SUPPLY

P: 1-866-733-0233  
www.solerpalaucanada.com

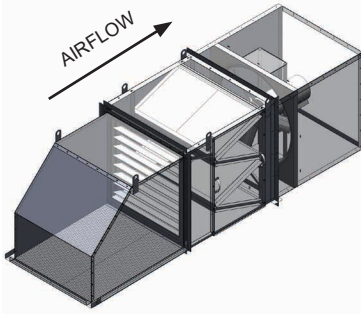

## Filtered Supply

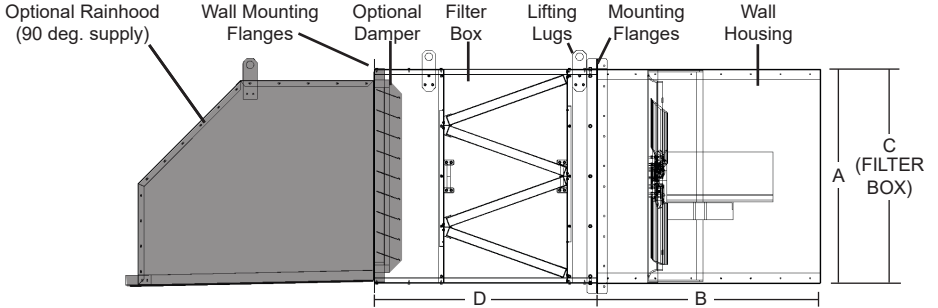

## Filtered Exhaust

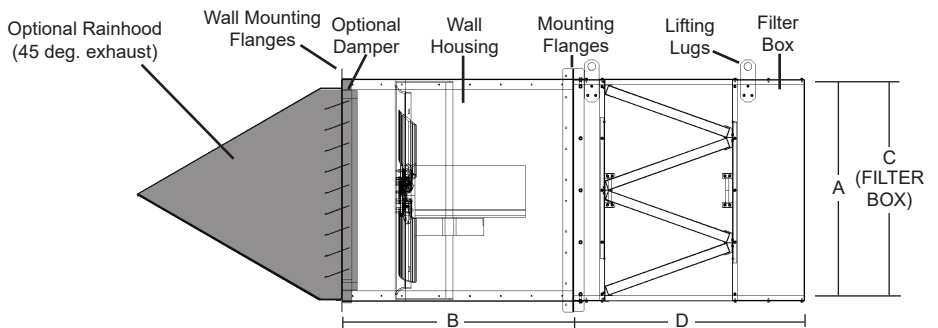

Fan Size	A (S.Q.) O.D.	Wall Housing				Minimum Wall Opening	Filter Box			
		B Length					C	D	# of Filters	Filter Actual Dimensions
		LC & L2	GED & DFE Only		DDE/DDS					
		Exh/Sup	Exhaust	Supply	Exh/Sup					
14/16	21	N/A	26	26	N/A	21 1/2	21	39	2	19 5/8 x 19 5/8 x 1 7/8
18/20	25	44 (20 only)	26	26	N/A	25 1/2	25	44 1/8	3	19 5/8 x 24 5/8 x 1 7/8
24	31	44	44	44	44	31 1/2	31	41 1/8	4	19 5/8 x 24 5/8 x 1 7/8
30	37	44	44	44	44	37 1/2	37	44 1/8	8	15 5/8 x 24 5/8 x 1 7/8
36	43	44	N/A	N/A	44	43 1/2	43	44 1/8	8	19 5/8 x 24 5/8 x 1 7/8
42	49	44	N/A	N/A	44	49 1/2	49	44 1/8	10	19 5/8 x 24 5/8 x 1 7/8
48	55	44	N/A	N/A	44	55 1/2	55	40 1/2	12	19 5/8 x 24 5/8 x 1 7/8
54	61	44	N/A	N/A	44	61 1/2	61	44 1/8	15	19 5/8 x 24 5/8 x 1 7/8
60	67	44	N/A	N/A	44	67 1/2	67	44 1/8	15	19 5/8 x 24 5/8 x 1 7/8

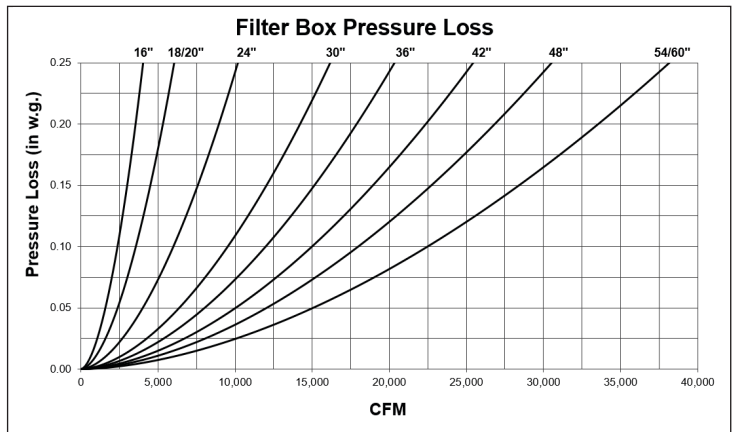
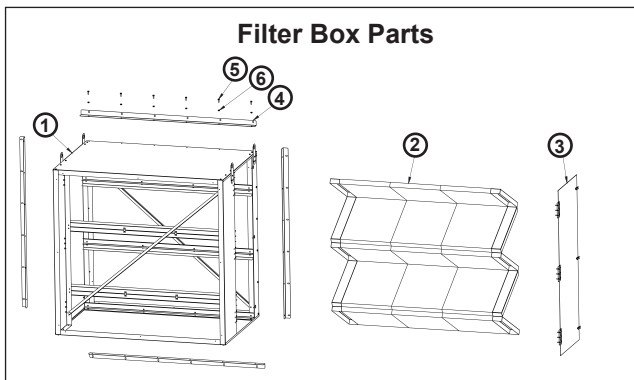

No	Description	No	Description
1	Filter Box Hinged Doors	4	Mounting Collar
2	Filter Pack	5	5/16"-18 x 3/4" Hex HD Cap Screw ZP
3	Door Hinged Assy	6	5/16" Flange Nut ZP

All specifications are subject to change without notice unless approved in submittal by S&P Canada.  
FWH\_Submittal\_V.3 / 0519

