



Premium Choice Value Series PCV50 & PCV80

(Ceiling Mounted Ventilation Fans)



Series Overview

Available in 2 sizes (PCV50 & PCV80) the Premium Choice Value Series, as the name suggests, is the best CHOICE for the VALUE! The fans come standard with aesthetically pleasing plastic grilles, but you have the CHOICE of a Light Kit (PCVLEDK or PCVLK). If you need a humidity sensing fan, or if you need to control the speed choose the Humidity Sensor (PCHS) for the PCV50 or PCV80, or Speed Control (PCSC) for the PCV80. The controls and lighted grille are all “Plug-and-Play” options meaning one fan can be modified to be the exact fan needed. You even have the CHOICE to add a control or change the grille after the initial installation.

Features & Benefits

- Quiet operation 1.5 to 2.5 Sones
- 50 and 80 CFM models
- 4” duct connector with built-in backdraft damper
- Housing size: 9” x 9” x 5-3/4”
- Robust steel housing
- Attractive, sturdy grille
- Thermally protected motor
- ETL Listed
- HVI Certified
- Model PCV80 is ENERGY STAR® qualified
- 5-year warranty

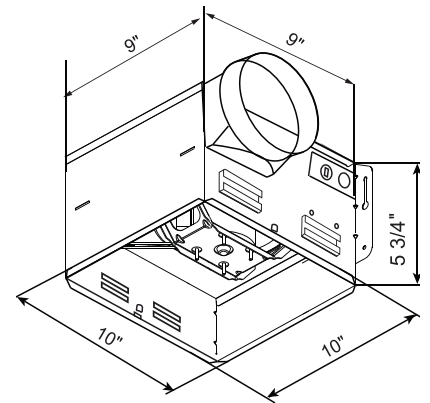

Options & Accessories

- Contractor Packs (4 packs)
- LED lighted grille kit
- Humidity Sensor, Plug-&-Play module (compatible with PCV50 & PCV80)
- Speed Control Plug-&-Play module (compatible with PCV80)
- Radiation Damper
- CFL lighted grille kit

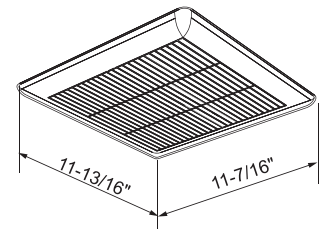

Performance

Model	Duct Size for Test	CFM @ Static Pressure (in. w.g.)		Static Pressure (in W.G.)	Watts	Power (V/Hz)	Sones
		0.1	0.25				
PCV50	4"	50	-	0.1	48.9	120/60	2.5
PCV80		80	60		23.8	120/60	1.5

Contact the factory for more information or additional submittal drawings. We are not responsible for fabrication changes or errors resulting from customer use of a non-current submittal drawing.

All specifications are subject to change without notice unless approved in submittal by S&P.
PCV_Submittal_v.3 / 09-2018