

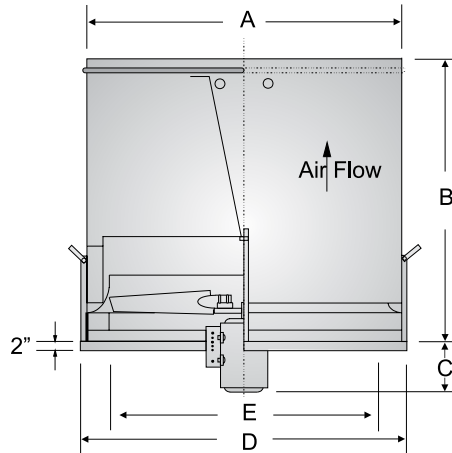

P: 866.733.0233
www.solerpalaucanada.com

MODEL UBX DIRECT DRIVE UPBLAST PROPELLER POWER ROOF VENTILATOR



Model UBX	A O.D. Windband	B (6) Height	C (5, 6) (Max.)	D I.D. Curb Cap	E Min. I.D. Opening	Std. Prefab Curb O.D.	Metal Guages (1)			Avg. Wt.
							Windband	Curb Cap	Fan Panel	
24	30	33	16	32 x 32	24 x 24	31 x 31	18	16	16	310
30	36	36	17	38 x 38	30 x 30	37 x 37	18	16	16	340
36	42	38	17	44 x 44	36 x 36	43 x 43	18	16	16	430
42	48	41	18	50 x 50	42 x 42	49 x 49	18	16	16	490
48	54	44	22	56 x 56	48 x 48	55 x 55	18	14	16	640
54	60	47	22	62 x 62	54 x 54	61 x 61	18	14	14	840
60	66	50	22	68 x 68	60 x 60	67 x 67	18	14	14	1000
72	80	56	31	82 x 82	72 x 72	81 x 81	18	12	12	1550

- (1) All materials are G90 galvanized steel.
- (2) Translucent fiberglass damper doors are standard on 48", 54", 60" and 72". (Available as an accessory on all other sizes.)
- (3) Propellers are available in 2, 3, 4 & 6 bladed, adjustable-pitch airfoil aluminum. (Fixed pitch, carbon steel or aluminum are also available.)
- (4) AMCA certified performance data is shown in bulletin UB0107.
- (5) Single-pipe frames are used on 1/2hp through 5hp/1160 RPM motors. Motors may extend below top of curbs (see "C" dim.).
- (6) Double-pipe frames are used on 5hp/870RPM motors and larger. Curb caps are modified so that motors do not extend below top of curb.

FAN SPECIFICATIONS									MOTOR SPECIFICATIONS				
Line	Qty.	Model No.	Tag	CFM	SP	Fan RPM	BHP	Sones	HP	Volts	Phase	Hertz	Encl
1													
2													
3													
4													
5													

ACCESSORY ITEMS	1	2	3	4	5	ACCESSORY ITEMS	1	2	3	4	5
<input type="checkbox"/>						<input type="checkbox"/>					
<input type="checkbox"/>						<input type="checkbox"/>					
<input type="checkbox"/>						<input type="checkbox"/>					
<input type="checkbox"/>						<input type="checkbox"/>					
<input type="checkbox"/>						<input type="checkbox"/>					

Project: _____ Submitted: _____
 Customer: _____ Approved: _____
 Location: _____

Subject to change unless approved in submittal by S&P Canada
UBX_Submittal_0107

