

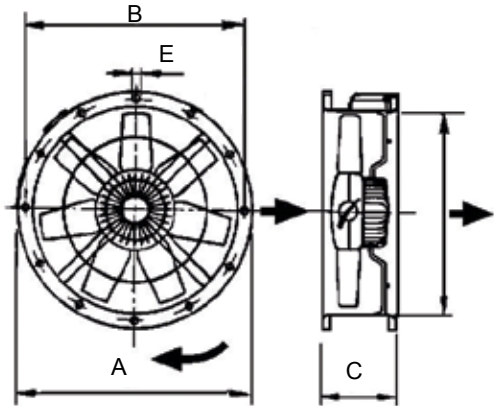

MODEL DA - Compact Duct Axial

(For Industrial and Commercial Applications)

P: 866.733.0233
www.solerpalaucanada.com



Dimensions inches/mm

Model	A	B	C	D	E	Weight (lbs)
DA 12	15 ^{3/16} 386	14 356	6 ^{11/16} 170	12 ^{7/16} 316	3/8 10	22
DA 16	19 ^{3/16} 487	17 ^{3/4} 451	6 ^{11/16} 170	15 ^{3/4} 400	1/2 13	31
DA 18	21 ^{1/8} 537	19 ^{11/16} 500	7 ^{1/8} 181	17 ^{3/4} 451	1/2 13	40
DA 20	23 ^{7/16} 595	22 ^{1/16} 560	7 ^{1/8} 181	19 ^{11/16} 500	1/2 13	49



Soler & Palau USA certifies that the DUCT AXIAL FANS shown herein are licensed to bear the AMCA Seal. The ratings shown are based on tests and procedures performed in accordance with AMCA publication 211 and AMCA publication 311 and comply with the requirements to the AMCA Certified Ratings Program.



FAN DATA					
Fan No.	Qty.	Model No.	CFM	SP	RPM

For more information contact us at www.solerpalau-usa.com or 1.800.961.7370 for additional submittal drawings.

MOTOR DATA					
AMPS	RPM	VOLTS	PH	HZ	ENCLOSURE

Soler & Palau will not be responsible for fabrication changes or errors resulting from customer use of a non-current submittal drawing.

ACCESSORIES	1	2	3	4	5	REMARKS