



P: 866.733.0233
www.solerpalaucanada.com



MODEL DB BELT DRIVE CENTRIFUGAL ROOF EXHAUSTER

STANDARD CONSTRUCTION FEATURES

- All aluminum exterior construction.
- Stainless steel exterior fasteners.
- Ventilated motor compartment.
- Prepunched curb cap with welded corners.
- Aluminum nonoverloading wheel.
- Adjustable V-Belt drive.
- Motor & drive factory mounted (except 182T and larger).
- Mounted service disconnect (except 2 speed and XP motors).
- Pillow block ball bearings (L50 = 200k with lube fittings).
- Internal wiring chase.
- Aluminum birdscreen and windband.
- Neoprene vibration isolators.
- AMCA Certified Air and Sound Performance.

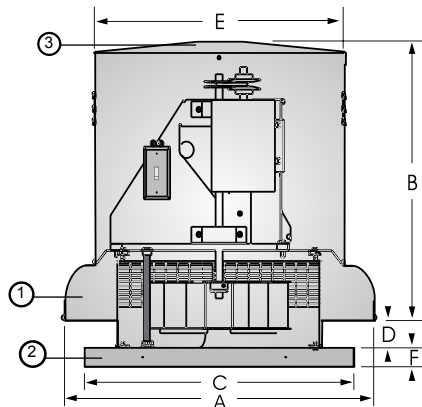

SIZE	DIMENSIONS (IN.)								Damper OD	MIN. METAL THICKNESS (ALUM.)			AVG. SHIP WT. LBS.
	A	B	C	D	E	F	G	H		SKIRT ①	CURB CAP ②	LID COVER ③	
6-8-9	20 1/2	17 1/2	16 1/2	3 1/2	16 1/8	1 3/4	14 3/4	11 1/2	11	.063	.050	.050	80
11	28 3/8	23	24	3 1/2	22 1/2	2	22 1/4	19 1/2	18	.080	.080	.050	130
12	28 3/8	23	24	3 1/2	22 1/2	2	22 1/4	19 1/2	18	.080	.080	.050	130
14	28 3/8	23	24	3 1/2	22 1/2	2	22 1/4	19 1/2	18	.080	.080	.050	140
16	32 1/4	24	24	6	26 1/4	2 1/2	22 1/4	19 1/2	18	.080	.080	.050	145
18	32 1/4	24	29 1/2	4 1/2	26 1/4	2 1/2	27 3/4	24 3/4	24	.090	.080	.050	160
20	36 3/4	24 1/2	29 1/2	4 1/2	26 1/4	2 1/2	27 3/4	24 3/4	24	.090	.080	.050	215
24	41 1/4	26 1/2	35 3/4	8 1/2	30	2 1/2	33 3/4	30 3/4	30	.090	.080	.050	290
30	58 3/8	37	42 1/2	5 1/2	41	2 1/2	40 3/4	37 3/4	36	.100	.090	.050	465
36	58 3/8	37	42 1/2	10	41	2 1/2	40 3/4	37 3/4	36	.100	.090	.050	475
42	73	40 1/2	55	10	54 5/8	2 1/2	53 1/4	50 1/4	48	.100	.090	.050	700
48	73	40 1/2	55	13	54 5/8	2 1/2	53 1/4	50 1/4	48	.100	.090	.050	830

A - Skirt OD (Dia). E - Motor cover OD (Dia).
 B - Height. F - Curb cap flange.
 C - Curb cap OD. G - Recommended roof curb OD (allows 3/4" for flashing).
 D - Skirt height. H - Recommended roof opening.

DIMENSIONS REPRESENT GENERAL CONSTRUCTION AND MAY VARY SLIGHTLY. CONTACT FACTORY FOR CERTIFIED DRAWINGS.

FAN SPECIFICATIONS									MOTOR SPECIFICATIONS				
Line	Qty.	Model No.	Tag	CFM	SP	Fan RPM	BHP	Sones	HP	Volts	Phase	Hertz	Encl
1													
2													
3													
4													
5													

ACCESSORY ITEMS	1	2	3	4	5	ACCESSORY ITEMS	1	2	3	4	5
<input type="checkbox"/>						<input type="checkbox"/>					
<input type="checkbox"/>						<input type="checkbox"/>					
<input type="checkbox"/>						<input type="checkbox"/>					
<input type="checkbox"/>						<input type="checkbox"/>					
<input type="checkbox"/>						<input type="checkbox"/>					

Subject to change unless approved in submittal by S&P.
DB_Submittal_0107(InDesign, pg1)

