

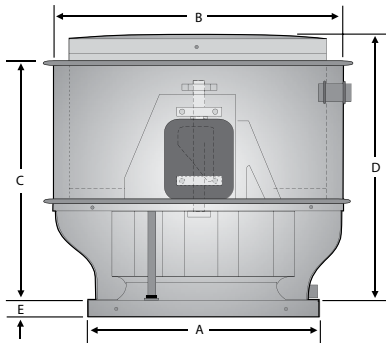

P: 866.733.0233
www.solerpalaucanada.com

MODEL TXB BELT DRIVE CENTRIFUGAL UPBLAST ROOF EXHAUSTER

SIZE	DIMENSIONS (IN.)							AVG. SHIP WT. (LBS)
	A	B	C	D	E	F	G	
8	16 1/2	24	24	27	1 3/4	11 3/4	14 3/4	69
10	16 1/2	27	26	29	1 3/4	11 3/4	14 3/4	69
12/15/16	24	31 1/2	26	29	2 1/2	19 1/4	22 1/4	93
18/20	29 1/2	37 3/4	28 1/2	32	2 1/2	24 3/4	27 3/4	120
24	35 1/2	47 1/4	31 1/2	42	2 1/2	30 3/4	33 3/4	245
30	42 1/2	56 3/4	41	45	2 1/2	37 3/4	40 3/4	365
36	42 1/2	66	44	48	2 1/2	37 3/4	40 3/4	365
42	55	72 1/2	48	52	2 1/2	50 1/4	53 1/4	385
48	55	78 3/4	52	56	2 1/2	50 1/4	53 1/4	490



- A - Inside dimension of square curb cap.
- B - Outside diameter of unit.
- C - Height of exhaust opening above curb cap.
- D - Height of unit above top of curb.
- E - Depth of curb mounting flange.
- F - Recommended roof opening.
- (Inside dimension of factory built prefab curb).
- G - Outside dimension of factory built prefab curb.

SIZE	METAL GAUGES				
	WIND BAND	MOTOR COVER	SHROUD	BASE	
				STD/UL	RHUL
8/10	.050	.050	.063	.063	16GA
12/15/16	.050	.050	.063	.063	16GA
18/20	.050	.050	.080	.080	16GA
24	.050	.050	.100	.080	16GA
30	.050	.050	.100	.090	16GA
36	.050	.050	.090	.090	16GA
42	.050	.050	.090	.100	N/A
48	.050	.050	.090	.100	N/A



cULus 705
cULus 762 (Grease)

FAN SPECIFICATIONS									MOTOR SPECIFICATIONS				
Line	Qty.	Model No.	Tag	CFM	SP	Fan RPM	BHP	Sones	HP	Volts	Phase	Hertz	Encl
1													
2													
3													
4													
5													

ACCESSORY ITEMS	1	2	3	4	5	ACCESSORY ITEMS	1	2	3	4	5
<input type="checkbox"/>						<input type="checkbox"/>					
<input type="checkbox"/>						<input type="checkbox"/>					
<input type="checkbox"/>						<input type="checkbox"/>					
<input type="checkbox"/>						<input type="checkbox"/>					
<input type="checkbox"/>						<input type="checkbox"/>					

Project: _____ Submitted: _____
 Customer: _____ Approved: _____
 Location: _____