

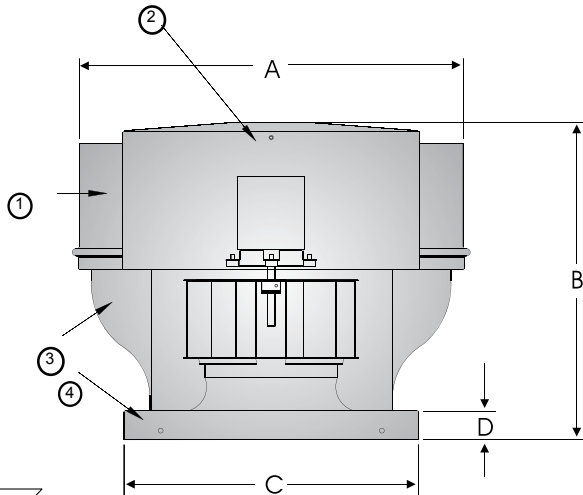

P: 866.733.0233  
www.solerpalaucanada.com

# MODEL TXD DIRECT DRIVE CENTRIFUGAL UPBLAST ROOF EXHAUSTER



OPTIONAL (Must be specified) **UL 705**  
**UL 762 (Grease)**

### STANDARD CONSTRUCTION FEATURES

- Aluminum Housing with Stainless Steel Exterior Fasteners.
- Aluminum Backward Inclined Wheel.
- Prepunched Aluminum Curb Cap with Welded Corners.
- Single Piece Aluminum Birdscreen & Windband.
- Neoprene Vibration Isolators.
- Conduit Wiring Chase.
- Factory Disconnect Switch or Plug Type. (Except XP & 2 Speed).

SIZE	DIMENSIONS (IN.)			
	A	B	C	D
6 / 8	24	22	16 1/2	2
10	27 1/4	22	16 1/2	2
12	31 1/2	23	24	2
14 / 15	31 1/2	23	24	2

A - Outside diameter of unit.  
B - Height of unit.  
C - Inside dimension of square curb cap.  
D - Depth of curb mounting flange.

SIZE	DIMENSIONS (IN.)			ALUMINUM METAL GAUGES				FAN WT. (LBS)	AVG. SHIP WT. (LBS)
	DAMPER OD	ROOF OPENING	CURB OD	WIND BAND ①	MOTOR COVER ②	SHROUD ③	BASE ④		
6 / 8	11	12	15	.050	.080	.063	.050	45	76
10	11	12	15	.050	.050	.063	.063	70	105
12	18	19 1/4	22 1/4	.050	.050	.063	.063	80	115
14 / 15	18	19 1/4	22 1/4	.050	.050	.063	.063	85	120

FAN SPECIFICATIONS									MOTOR SPECIFICATIONS				
Line	Qty.	Model No.	Tag	CFM	SP	Fan RPM	BHP	Sones	HP	Volts	Phase	Hertz	Encl
1													
2													
3													
4													
5													

ACCESSORY ITEMS					ACCESSORY ITEMS						
	1	2	3	4	5		1	2	3	4	5
<input type="checkbox"/>						<input type="checkbox"/>					
<input type="checkbox"/>						<input type="checkbox"/>					
<input type="checkbox"/>						<input type="checkbox"/>					
<input type="checkbox"/>						<input type="checkbox"/>					
<input type="checkbox"/>						<input type="checkbox"/>					

Subject to change unless approved in submittal by S&P.  
TXD\_0107(InDesign, pg1)

