

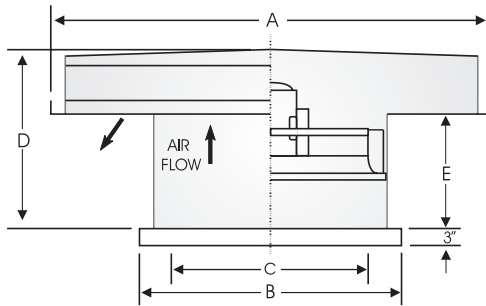

# MODELS HREB-C, HREB-P & HRED-C HOODED POWER ROOF EXHAUST VENTILATORS

Model HREB-C Belt Driven Aluminum Airfoil Props  
 Model HRED-C Direct Driven Aluminum Airfoil Props  
 Model HREB-P Belt Driven Polypropylene Props



Model HREB-C Belt Drive  
 (Hoods on 42" - 72" ship KD) (2)  
 Specify assembled if required

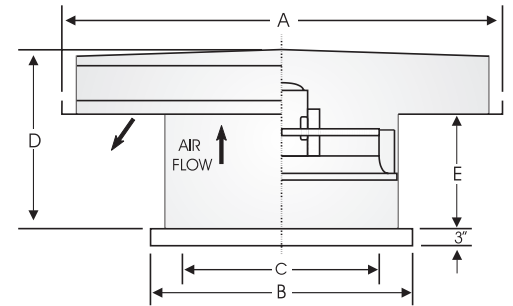

Model HRED-C Direct Drive  
 (Hoods on 42" - 60" ship KD) (2)  
 Specify assembled if required



HREB-C only

MODEL HREB-C, HRED-C, HREB-P	A SQ. O.D. HOOD (2)	B I.D. CURB CAP	C MIN I.D. OPENING	D HEIGHT	E STACK	PREFAB CURB O.D.	METAL GAUGES (1)			AVG. WT.
							CROWN/ SIDE HOOD	BASE	CURB CAP	
24	58	35	30	44	23	33-1/4	18/18	16	16	425
30	66	41	36	44	23	39-1/4	18/18	16	16	550
36	78	47	42	44	23	45-1/4	18/18	16	16	700
42	87	53	48	51	30	51-1/4	18/16	16	16	800
48	99	59	54	51	30	57-1/4	18/16	16	14	1100
54	111	65	60	51	30	63-1/4	18/16	14	14	1300
60	111 OR 123	71	66	51	30	69-1/4	18/16	14	14	1550
72	123	85	79	56	35	84-1/2	18/16	14	12	1680

1. All materials are G90 galvanized steel.
2. Hoods for fan sizes 24-36" ship assembled. Hoods for fan sizes 42-72" ship KD unless ordered factory assembled. Assembled 123" hoods must ship by double drop deck flat bed truck.
3. Hoods will hinge and front panel is removable for access to fan and optional damper.
4. HREB-C and HRED-C Propellers are 2, 3, 4, or 6-bladed adjustable pitch, air-foil aluminum (Fixed pitch steel and Aluminum are also available). HREB-P propeller is glass reinforced polypropylene.
5. Dampers mount on accessory flanges inside curbs or in the duct due to space restrictions.
6. Delay switch required on models 10HP and larger with motorized damper (optional).