

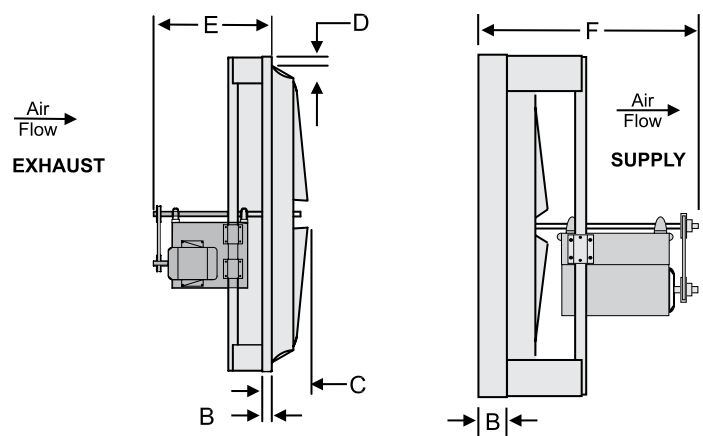

P: 866.733.0233
www.solerpalaucanada.com

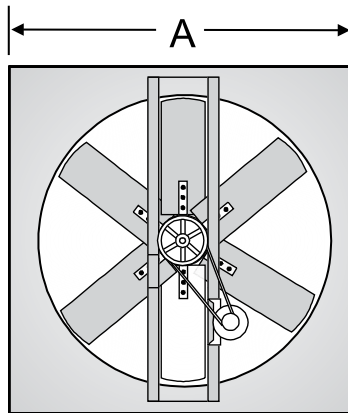

MODEL L2E (Exhaust) & L2S (Supply) SIDEWALL PROPELLER FAN - BELT DRIVE LEVEL 2 CONSTRUCTION



SIZE	A SQ. O.D. PANEL	E	F	B	C	D	APPROX WT.	MAX MOTOR	MATERIAL GAUGE OR THICKNESS								
									SHAFT	PANEL		SUPPORT FRAME		BLADES		HUB	PIPE FRAME
										Galv	Alum	Galv	Alum	Galv	Alum		
24	30	22	26	2	7 1/2	1 1/4	120	145T	1	18	.08	14	1/4	16	.08	1/4	1 1/4" OD SCHED. 40
30	36	22	26	2	7 1/2	1 1/4	180	182T	1	18	.08	10	1/4	16	.08	1/4	
36	42	22	26	2	7 1/2	1 1/4	215	184T	1-3/16	18	.08	10	1/4	16	.08	1/4	
42	48	22	26	2	7 1/2	1 1/4	235	184T	1-3/16	16	.08	10	1/4	16	.08	3/8	
48	54	22	26	2	7 1/2	1 1/4	300	184T	1-3/16	16	.100	10	1/4	16	.08	3/8	
54	60	22	26	2	7 1/2	1 1/4	400	184T	1-3/16	14	.100	10	1/4	16	.08	3/8	
60	66	24	28	2	7 1/2	1 1/4	490	184T	1-3/16	14	.100	10	1/4	16	.08	3/8	

CONSTRUCTION AND MATERIAL SPECIFICATION - LEVEL 2

Fan panel, motor & bearing mounts - all welded G90 galvanized steel.

Pipe support frame - Welded 1 1/4" OD schedule 40 galvanized pipe.

Fan Blades - G90 galvanized (multiple laminations), bolted to hub.

Hub - Heavy-duty welded steel, epoxy coated, keyed to shaft.

Bearings - Air handling, self aligning, cast iron pillow block with grease fittings, L50 = 200,000 hours average life.

Shaft - Turned, ground and polished, keyed to propeller hub and sheave.

Drives - Cast iron, 150% S.F., single groove and adjustable thru 3HP, keyed to motor and fan shaft.

Belts - Nonstatic conducting, oil resistant, single groove thru 3HP.

FAN SPECIFICATIONS									MOTOR SPECIFICATIONS				
Line	Qty.	Model No.	Tag	CFM	SP	Fan RPM	BHP	Sones	HP	Volts	Phase	Hertz	Encl
1													
2													
3													
4													
5													

ACCESSORY ITEMS					ACCESSORY ITEMS						
	1	2	3	4	5		1	2	3	4	5
<input type="checkbox"/>						<input type="checkbox"/>					
<input type="checkbox"/>						<input type="checkbox"/>					
<input type="checkbox"/>						<input type="checkbox"/>					
<input type="checkbox"/>						<input type="checkbox"/>					
<input type="checkbox"/>						<input type="checkbox"/>					

Subject to change unless approved in submittal by S&P.

L2_Submittal_0107(InDesign, pg1)

