



MODEL SMXD

Direct Drive Mixed Flow Fan

FEATURES

- Heavy-gauge rolled steel construction
- Continuously welded and epoxy coated
- Integral inlet and outlet flanges with mounting holes
- Standard bolted - wheel inspection door
- Steel wheel for light and heavy duty applications
- For indoor / outdoor use
- AMCA Air and Sound Certified
- cULus 705 Listed



SMXD15

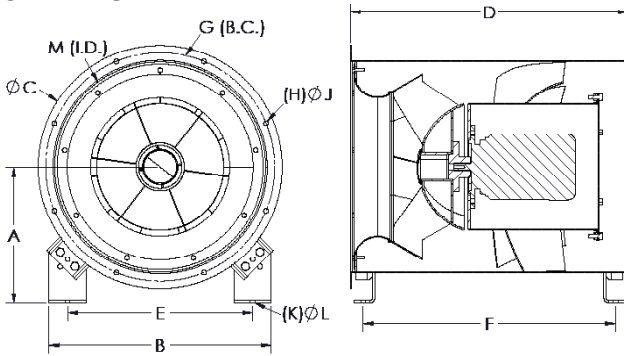

Size	A	B	C	D	E	F	G	(H) Ø J	(K) Ø L	M
SMXD15	13-3/4	22-5/8	25-3/16	28-9/16	19-1/16	26-3/16	23-3/4	(8) 15/32	(4) 15/32	20

SMXD16-24

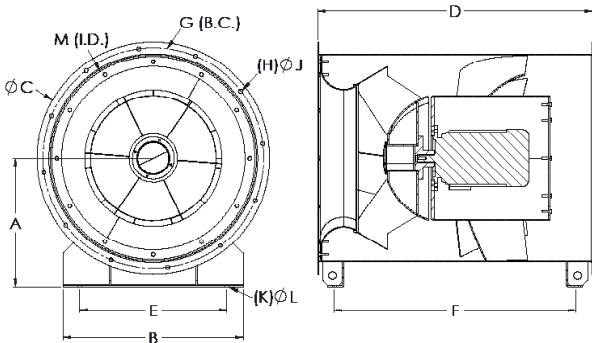

Size	A	B	C	D	E	F	G	(H) Ø J	(K) Ø L	M
SMXD16	15-9/16	21-5/8	27-15/16	33-1/16	17-11/16	29-1/8	26-9/16	(12) 15/32	(4) 15/32	24-13/16
SMXD18	17-1/8	24-7/16	31-3/16	34-11/16	20-1/2	30-3/4	29-11/16	(12) 15/32	(4) 15/32	28
SMXD20	19-1/8	27-9/16	35	38-1/2	23-5/8	34-9/16	33-5/8	(12) 15/32	(4) 15/32	31-7/8
SMXD22	21-1/16	31-1/8	39	44-5/8	27-3/16	39-1/8	37-9/16	(16) 15/32	(4) 15/32	35-13/16
SMXD24	23-1/4	35-1/16	43-3/16	50-3/16	31-1/8	44-11/16	41-11/16	(16) 15/32	(4) 15/32	40-1/16