



P: 866.733.0233
www.solerpalaucanada.com

MODEL SQB

SQUARE INLINE BELT DRIVE DUCT FAN

STANDARD FEATURES

- Non-overloading, backwardly inclined wheel.
- Spark resistant wheel on all sizes.
- Safety disconnect standard for all motors except two speed and explosion proof (shipped loose).
- Housing corrosion resistant galvanized steel.
- Heavy duty internal support structure.
- Integral duct flanges.
- UL 705 label for Electrical Safety & Reliability.

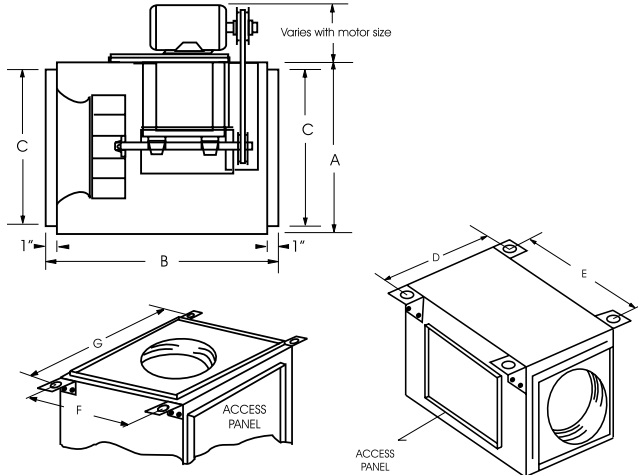

NOTE: Optional Mounting Brackets may be mounted on sides or ends of unit for floor, ceiling or vertical mounting.

(ARRANGE FOR BEST USE OF ACCESS PANELS)



SIZE	STANDARD DIMENSIONS (IN.)						
	A	B	C	D	E	F	G
7 & 8	15	23	11 7/8	18 1/2	19	13	19 3/4
10	17	23	13 7/8	20 1/2	19	15	21 3/4
12	21	23	17 7/8	24 1/2	19	19	25 3/4
15	24	30	21 7/8	27 1/2	24	22	28 3/4
18	28	30	23 7/8	31 1/2	26	26	32 3/4
20	32	34	27 7/8	35 1/2	30	30	36 3/4
24	39	38	34 7/8	42 1/2	34	37	43 3/4
30	44	40	39 7/8	47 1/2	36	42	48 3/4
36	52	45	47 7/8	55 1/2	41	50	56 3/4
42	58	53	53 7/8	61 1/2	49	56	62 3/4

SIZE	STANDARD MATERIAL & THICKNESS				AVG SHIP WT (LBS)	INLET OR OUTLET AREA
	GALV HOUSING GAUGE	VENTURI INLET	SHAFT DIA. (CRS)	STD WHEEL		
7 & 8	18	18	5/8	Alum	75	1.0 Sq Ft
10	18	18	5/8	Alum	85	1.36 Sq Ft
12	18	18	3/4	Alum	95	2.25 Sq Ft
15	18	18	3/4	Alum	145	3.36 Sq Ft
18	18	18	1	Alum	190	4.0 Sq Ft
20	18	18	1	Alum	220	5.45 Sq Ft
24	18	18	1 or 1 3/16	Alum	320	8.5 Sq Ft
30	16	16	1 or 1 1/2	Alum	420	11.1 Sq Ft
36	16	16	1 3/16 or 1 1/2	Alum	600	16.0 Sq Ft
42	16	16	1 1/2	Alum	725	20.25 Sq Ft

FAN SPECIFICATIONS									MOTOR SPECIFICATIONS				
Line	Qty.	Model No.	Tag	CFM	SP	Fan RPM	BHP	Sones	HP	Volts	Phase	Hertz	Encl
1													
2													
3													
4													
5													

ACCESSORY ITEMS					1	2	3	4	5	ACCESSORY ITEMS					1	2	3	4	5
<input type="checkbox"/>										<input type="checkbox"/>									
<input type="checkbox"/>										<input type="checkbox"/>									
<input type="checkbox"/>										<input type="checkbox"/>									
<input type="checkbox"/>										<input type="checkbox"/>									
<input type="checkbox"/>										<input type="checkbox"/>									

Project: _____ Submitted: _____
 Customer: _____ Approved: _____
 Location: _____